

MN Dept of Transportation

TRAFFIC DATA COLLECTION - Metro

TH-3 at 255th St W / CSAH-80

Ref.Pt.: 021.840

video RE

TURN MOVEMENT COUNT

File Name : TH-3 at 255th St 2014

Site Code :

Start Date : 12/10/2014

Page No : 1

Groups Printed- Cars +

| Start Time | TH-3 Southbound | | | | 255th St W / CSAH 80 Westbound | | | | TH-3 Northbound | | | | 255th St W Eastbound | | | | Int. Total |
|-----------------|-----------------|------|-------|------|--------------------------------|------|-------|------|-----------------|------|-------|------|----------------------|------|-------|------|------------|
| | Left | Thru | Right | Peds | Left | Thru | Right | Peds | Left | Thru | Right | Peds | Left | Thru | Right | Peds | |
| 06:00 | 0 | 12 | 0 | 0 | 1 | 1 | 2 | 0 | 0 | 25 | 0 | 0 | 1 | 0 | 1 | 0 | 43 |
| 06:15 | 0 | 24 | 0 | 0 | 0 | 1 | 1 | 0 | 1 | 21 | 0 | 0 | 0 | 0 | 0 | 0 | 48 |
| 06:30 | 0 | 30 | 0 | 0 | 0 | 0 | 4 | 0 | 0 | 45 | 0 | 0 | 0 | 0 | 0 | 0 | 79 |
| 06:45 | 1 | 43 | 0 | 0 | 1 | 0 | 7 | 0 | 0 | 61 | 0 | 0 | 1 | 0 | 0 | 0 | 114 |
| Total | 1 | 109 | 0 | 0 | 2 | 2 | 14 | 0 | 1 | 152 | 0 | 0 | 2 | 0 | 1 | 0 | 284 |
| 07:00 | 0 | 46 | 0 | 0 | 0 | 2 | 2 | 0 | 0 | 60 | 0 | 0 | 0 | 0 | 1 | 0 | 111 |
| 07:15 | 1 | 31 | 0 | 0 | 0 | 2 | 1 | 0 | 0 | 50 | 0 | 0 | 0 | 0 | 0 | 0 | 85 |
| 07:30 | 2 | 40 | 0 | 0 | 0 | 0 | 3 | 0 | 1 | 46 | 0 | 0 | 0 | 0 | 0 | 0 | 92 |
| 07:45 | 2 | 37 | 0 | 0 | 2 | 0 | 4 | 0 | 1 | 49 | 1 | 0 | 2 | 0 | 0 | 0 | 98 |
| Total | 5 | 154 | 0 | 0 | 2 | 4 | 10 | 0 | 2 | 205 | 1 | 0 | 2 | 0 | 1 | 0 | 386 |
| 08:00 | 0 | 36 | 0 | 0 | 0 | 0 | 2 | 0 | 0 | 53 | 0 | 0 | 1 | 0 | 0 | 0 | 92 |
| 08:15 | 0 | 25 | 1 | 0 | 0 | 0 | 2 | 0 | 0 | 26 | 1 | 0 | 0 | 0 | 1 | 0 | 56 |
| 08:30 | 0 | 30 | 1 | 0 | 0 | 0 | 1 | 0 | 0 | 32 | 0 | 0 | 1 | 0 | 0 | 0 | 65 |
| 08:45 | 0 | 27 | 0 | 0 | 1 | 0 | 3 | 0 | 0 | 28 | 1 | 0 | 0 | 0 | 1 | 0 | 61 |
| Total | 0 | 118 | 2 | 0 | 1 | 0 | 8 | 0 | 0 | 139 | 2 | 0 | 2 | 0 | 2 | 0 | 274 |
| *****BREAK***** | | | | | | | | | | | | | | | | | |
| 15:00 | 2 | 30 | 0 | 0 | 0 | 0 | 1 | 0 | 0 | 29 | 0 | 0 | 0 | 0 | 1 | 0 | 63 |
| 15:15 | 2 | 41 | 0 | 0 | 0 | 0 | 3 | 0 | 0 | 28 | 0 | 0 | 0 | 0 | 0 | 0 | 74 |
| 15:30 | 3 | 38 | 2 | 0 | 0 | 0 | 1 | 0 | 0 | 40 | 0 | 0 | 1 | 0 | 1 | 0 | 86 |
| 15:45 | 1 | 54 | 0 | 0 | 1 | 0 | 1 | 0 | 0 | 39 | 1 | 0 | 1 | 1 | 1 | 0 | 100 |
| Total | 8 | 163 | 2 | 0 | 1 | 0 | 6 | 0 | 0 | 136 | 1 | 0 | 2 | 1 | 3 | 0 | 323 |
| 16:00 | 3 | 63 | 0 | 0 | 1 | 0 | 0 | 0 | 0 | 38 | 0 | 0 | 1 | 1 | 0 | 0 | 107 |
| 16:15 | 2 | 49 | 0 | 0 | 0 | 1 | 1 | 0 | 0 | 46 | 2 | 0 | 0 | 2 | 0 | 0 | 103 |
| 16:30 | 2 | 70 | 1 | 0 | 0 | 0 | 1 | 0 | 0 | 42 | 1 | 0 | 1 | 0 | 0 | 0 | 118 |
| 16:45 | 3 | 44 | 1 | 0 | 0 | 1 | 1 | 0 | 1 | 45 | 0 | 0 | 0 | 0 | 0 | 0 | 96 |
| Total | 10 | 226 | 2 | 0 | 1 | 2 | 3 | 0 | 1 | 171 | 3 | 0 | 2 | 3 | 0 | 0 | 424 |
| 17:00 | 3 | 53 | 0 | 0 | 0 | 0 | 0 | 0 | 0 | 47 | 0 | 0 | 1 | 0 | 0 | 0 | 104 |
| 17:15 | 1 | 44 | 1 | 0 | 2 | 0 | 1 | 0 | 0 | 60 | 0 | 0 | 0 | 1 | 0 | 0 | 110 |
| 17:30 | 1 | 48 | 1 | 0 | 0 | 1 | 2 | 0 | 0 | 53 | 0 | 0 | 0 | 0 | 0 | 0 | 106 |
| 17:45 | 2 | 36 | 0 | 0 | 0 | 0 | 1 | 0 | 1 | 28 | 0 | 0 | 0 | 0 | 0 | 0 | 68 |
| Total | 7 | 181 | 2 | 0 | 2 | 1 | 4 | 0 | 1 | 188 | 0 | 0 | 1 | 1 | 0 | 0 | 388 |
| Grand Total | 31 | 951 | 8 | 0 | 9 | 9 | 45 | 0 | 5 | 991 | 7 | 0 | 11 | 5 | 7 | 0 | 2079 |
| Apprch % | 3.1 | 96.1 | 0.8 | 0 | 14.3 | 14.3 | 71.4 | 0 | 0.5 | 98.8 | 0.7 | 0 | 47.8 | 21.7 | 30.4 | 0 | |
| Total % | 1.5 | 45.7 | 0.4 | 0 | 0.4 | 0.4 | 2.2 | 0 | 0.2 | 47.7 | 0.3 | 0 | 0.5 | 0.2 | 0.3 | 0 | |

MN Dept of Transportation

TRAFFIC DATA COLLECTION - Metro

TH-3 at 255th St W / CSAH-80
 Ref.Pt.: 021.840
 video RE
 TURN MOVEMENT COUNT

File Name : TH-3 at 255th St 2014
 Site Code :
 Start Date : 12/10/2014
 Page No : 2

| Start Time | TH-3 Southbound | | | | | 255th St W / CSAH 80 Westbound | | | | | TH-3 Northbound | | | | | 255th St W Eastbound | | | | | Int. Total |
|--|-----------------|------|-------|------|------------|--------------------------------|------|-------|------|------------|-----------------|------|-------|------|------------|----------------------|------|-------|------|------------|------------|
| | Left | Thru | Right | Peds | App. Total | Left | Thru | Right | Peds | App. Total | Left | Thru | Right | Peds | App. Total | Left | Thru | Right | Peds | App. Total | |
| Peak Hour Analysis From 06:00 to 08:45 - Peak 1 of 1 | | | | | | | | | | | | | | | | | | | | | |
| Peak Hour for Entire Intersection Begins at 06:45 | | | | | | | | | | | | | | | | | | | | | |
| 06:45 | 1 | 43 | 0 | 0 | 44 | 1 | 0 | 7 | 0 | 8 | 0 | 61 | 0 | 0 | 61 | 1 | 0 | 0 | 0 | 1 | 114 |
| 07:00 | 0 | 46 | 0 | 0 | 46 | 0 | 2 | 2 | 0 | 4 | 0 | 60 | 0 | 0 | 60 | 0 | 0 | 1 | 0 | 1 | 111 |
| 07:15 | 1 | 31 | 0 | 0 | 32 | 0 | 2 | 1 | 0 | 3 | 0 | 50 | 0 | 0 | 50 | 0 | 0 | 0 | 0 | 0 | 85 |
| 07:30 | 2 | 40 | 0 | 0 | 42 | 0 | 0 | 3 | 0 | 3 | 1 | 46 | 0 | 0 | 47 | 0 | 0 | 0 | 0 | 0 | 92 |
| Total Volume | 4 | 160 | 0 | 0 | 164 | 1 | 4 | 13 | 0 | 18 | 1 | 217 | 0 | 0 | 218 | 1 | 0 | 1 | 0 | 2 | 402 |
| % App. Total | 2.4 | 97.6 | 0 | 0 | | 5.6 | 22.2 | 72.2 | 0 | | 0.5 | 99.5 | 0 | 0 | | 50 | 0 | 50 | 0 | | |
| PHF | .500 | .870 | .000 | .000 | .891 | .250 | .500 | .464 | .000 | .563 | .250 | .889 | .000 | .000 | .893 | .250 | .000 | .250 | .000 | .500 | .882 |

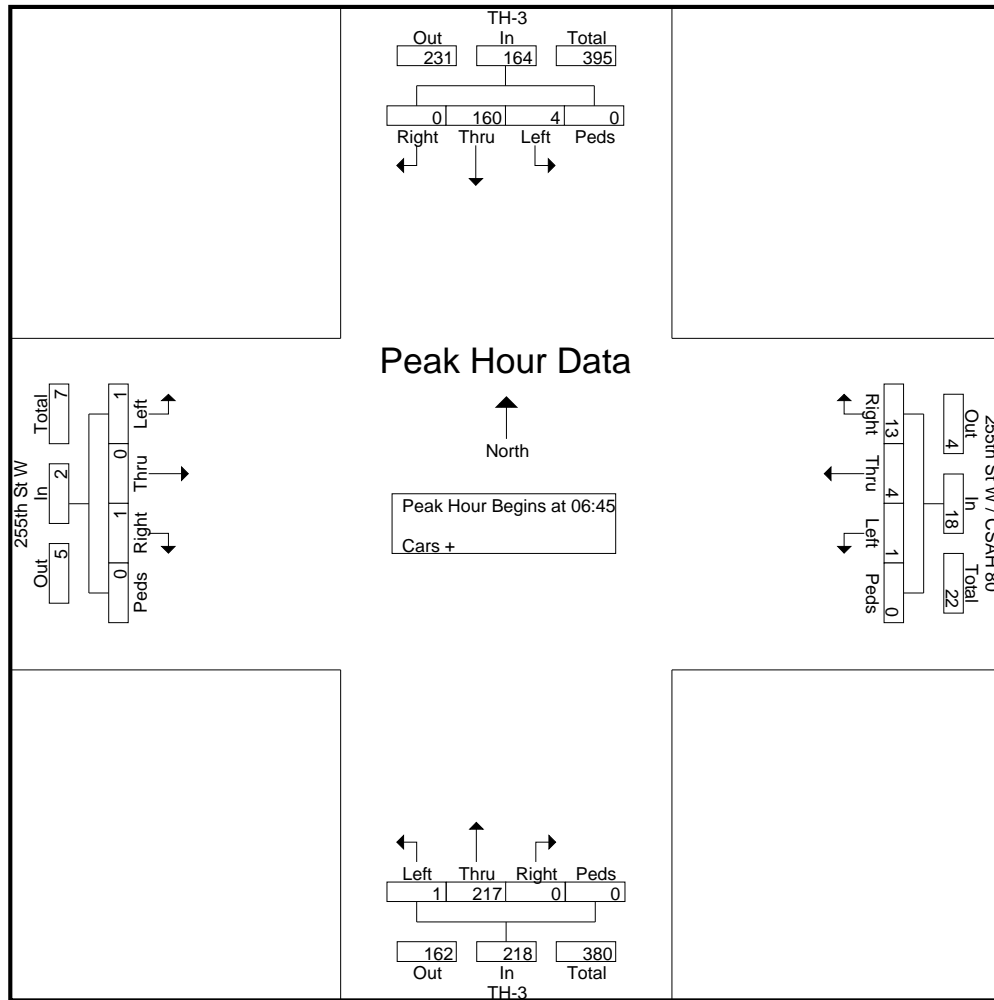

MN Dept of Transportation

TRAFFIC DATA COLLECTION - Metro

TH-3 at 255th St W / CSAH-80
 Ref.Pt.: 021.840
 video RE
 TURN MOVEMENT COUNT

File Name : TH-3 at 255th St 2014
 Site Code :
 Start Date : 12/10/2014
 Page No : 3

| Start Time | TH-3 Southbound | | | | | 255th St W / CSAH 80 Westbound | | | | | TH-3 Northbound | | | | | 255th St W Eastbound | | | | | Int. Total |
|--|-----------------|------|-------|------|------------|--------------------------------|------|-------|------|------------|-----------------|------|-------|------|------------|----------------------|------|-------|------|------------|------------|
| | Left | Thru | Right | Peds | App. Total | Left | Thru | Right | Peds | App. Total | Left | Thru | Right | Peds | App. Total | Left | Thru | Right | Peds | App. Total | |
| Peak Hour Analysis From 15:00 to 17:45 - Peak 1 of 1 | | | | | | | | | | | | | | | | | | | | | |
| Peak Hour for Entire Intersection Begins at 15:45 | | | | | | | | | | | | | | | | | | | | | |
| 15:45 | 1 | 54 | 0 | 0 | 55 | 1 | 0 | 1 | 0 | 2 | 0 | 39 | 1 | 0 | 40 | 1 | 1 | 1 | 0 | 3 | 100 |
| 16:00 | 3 | 63 | 0 | 0 | 66 | 1 | 0 | 0 | 0 | 1 | 0 | 38 | 0 | 0 | 38 | 1 | 1 | 0 | 0 | 2 | 107 |
| 16:15 | 2 | 49 | 0 | 0 | 51 | 0 | 1 | 1 | 0 | 2 | 0 | 46 | 2 | 0 | 48 | 0 | 2 | 0 | 0 | 2 | 103 |
| 16:30 | 2 | 70 | 1 | 0 | 73 | 0 | 0 | 1 | 0 | 1 | 0 | 42 | 1 | 0 | 43 | 1 | 0 | 0 | 0 | 1 | 118 |
| Total Volume | 8 | 236 | 1 | 0 | 245 | 2 | 1 | 3 | 0 | 6 | 0 | 165 | 4 | 0 | 169 | 3 | 4 | 1 | 0 | 8 | 428 |
| % App. Total | 3.3 | 96.3 | 0.4 | 0 | | 33.3 | 16.7 | 50 | 0 | | 0 | 97.6 | 2.4 | 0 | | 37.5 | 50 | 12.5 | 0 | | |
| PHF | .667 | .843 | .250 | .000 | .839 | .500 | .250 | .750 | .000 | .750 | .000 | .897 | .500 | .000 | .880 | .750 | .500 | .250 | .000 | .667 | .907 |

