

Alliant Engineering Inc Minneapolis, MN 55415

TH-3 at Cliff Rd / CSAH-32
Ref.Pt.: 036.776
Alliant Engineering Inc
TURN MOVEMENT COUNT

File Name : 20_TH 3 at Cliff Rd_022410
Site Code : 00000020
Start Date : 2/24/2010
Page No : 1

Groups Printed- Unshifted - Bank 1

Start Time	Robert Trail S (TH-3) Southbound				Cliff Rd (Co Rd 32) Westbound				Robert Trail S (TH-3) Northbound				Cliff Rd (Co Rd 32) Eastbound				Int. Total
	Left	Thru	Right	Peds	Left	Thru	Right	Peds	Left	Thru	Right	Peds	Left	Thru	Right	Peds	
06:30	2	20	3	0	7	38	21	0	12	135	8	0	10	30	11	0	297
06:45	9	30	3	0	17	42	27	0	17	200	13	0	9	25	9	0	401
Total	11	50	6	0	24	80	48	0	29	335	21	0	19	55	20	0	698
07:00	7	39	1	0	32	38	35	0	12	205	9	0	4	15	13	0	410
07:15	4	42	6	0	25	42	34	0	22	194	8	0	17	17	15	0	426
07:30	9	39	5	0	12	50	40	0	21	177	15	0	13	25	12	0	418
07:45	6	60	2	0	13	50	41	0	12	240	12	0	18	27	16	0	497
Total	26	180	14	0	82	180	150	0	67	816	44	0	52	84	56	0	1751
08:00	9	46	3	0	9	40	19	0	27	163	5	0	10	29	11	0	371
08:15	7	35	4	0	5	26	16	0	9	134	12	0	11	19	5	0	283
08:30	7	41	5	0	2	37	12	0	6	121	12	0	10	20	12	0	285
08:45	4	41	8	0	5	28	18	0	15	110	10	0	6	14	20	0	279
Total	27	163	20	0	21	131	65	0	57	528	39	0	37	82	48	0	1218
09:00	7	43	5	0	12	24	18	0	15	92	9	0	8	17	9	0	259
09:15	7	32	13	0	4	30	11	0	18	92	13	0	7	23	16	0	266
*** BREAK ***																	
Total	14	75	18	0	16	54	29	0	33	184	22	0	15	40	25	0	525
*** BREAK ***																	
10:30	5	27	3	0	1	15	7	0	6	57	9	0	4	20	9	1	164
10:45	4	34	6	0	7	18	8	0	8	49	7	0	2	13	7	0	163
Total	9	61	9	0	8	33	15	0	14	106	16	0	6	33	16	1	327
11:00	7	39	9	0	4	20	7	0	8	43	4	0	2	13	12	0	168
11:15	6	27	1	0	6	10	6	0	13	40	4	0	4	12	5	0	134
11:30	8	33	6	0	6	18	12	0	11	36	6	0	2	28	9	0	175
11:45	11	50	7	0	4	16	7	0	16	44	5	0	3	19	7	0	189
Total	32	149	23	0	20	64	32	0	48	163	19	0	11	72	33	0	666
12:00	12	43	8	0	6	9	10	0	3	57	4	0	4	25	11	0	192
12:15	9	36	5	0	9	14	9	0	13	56	5	0	6	18	14	0	194
12:30	13	61	14	0	6	22	9	0	10	46	6	0	4	15	12	0	218
12:45	5	42	8	0	3	17	2	0	14	43	6	0	2	18	20	0	180
Total	39	182	35	0	24	62	30	0	40	202	21	0	16	76	57	0	784
13:00	7	42	3	0	5	16	9	0	15	41	6	0	3	21	15	0	183
13:15	11	41	4	0	1	12	2	0	10	43	6	0	5	21	14	0	170
*** BREAK ***																	
Total	18	83	7	0	6	28	11	0	25	84	12	0	8	42	29	0	353
*** BREAK ***																	
14:30	12	79	7	0	2	12	9	0	12	52	21	0	3	24	8	0	241
14:45	9	78	6	0	11	27	8	0	16	58	7	0	7	31	14	0	272
Total	21	157	13	0	13	39	17	0	28	110	28	0	10	55	22	0	513
15:00	12	94	8	0	8	17	6	0	12	54	9	0	2	29	15	0	266
15:15	16	113	13	0	11	25	6	0	14	40	5	0	2	21	21	0	287
15:30	12	120	8	0	6	7	9	0	11	51	14	0	4	35	15	0	292
15:45	20	154	10	0	11	26	4	0	6	48	6	0	9	43	31	0	368
Total	60	481	39	0	36	75	25	0	43	193	34	0	17	128	82	0	1213
16:00	12	131	8	0	13	18	6	0	15	49	6	0	4	40	28	0	330
16:15	21	180	13	0	11	35	13	0	16	45	4	0	13	26	31	0	408

Alliant Engineering Inc Minneapolis, MN 55415

TH-3 at Cliff Rd / CSAH-32
 Ref.Pt.: 036.776
 Alliant Engineering Inc
 TURN MOVEMENT COUNT

File Name : 20_TH 3 at Cliff Rd_022410
 Site Code : 00000020
 Start Date : 2/24/2010
 Page No : 2

Groups Printed- Unshifted - Bank 1

Start Time	Robert Trail S (TH-3) Southbound				Cliff Rd (Co Rd 32) Westbound				Robert Trail S (TH-3) Northbound				Cliff Rd (Co Rd 32) Eastbound				Int. Total
	Left	Thru	Right	Peds	Left	Thru	Right	Peds	Left	Thru	Right	Peds	Left	Thru	Right	Peds	
16:30	32	202	20	0	20	34	15	0	7	59	2	0	10	49	36	0	486
16:45	28	208	8	0	15	18	9	0	16	60	10	0	12	42	30	0	456
Total	93	721	49	0	59	105	43	0	54	213	22	0	39	157	125	0	1680
17:00	36	194	9	0	11	40	7	0	7	51	7	0	10	51	19	0	442
17:15	29	232	11	0	14	41	13	0	10	46	12	0	18	63	32	0	521
17:30	39	188	22	0	24	36	7	0	10	70	16	0	7	50	26	0	495
17:45	29	203	12	0	21	27	12	0	9	40	7	0	10	40	28	0	438
Total	133	817	54	0	70	144	39	0	36	207	42	0	45	204	105	0	1896
Grand Total	483	3119	287	0	379	995	504	0	474	3141	320	0	275	1028	618	1	11624
Apprch %	12.4	80.2	7.4	0	20.2	53	26.8	0	12	79.8	8.1	0	14.3	53.5	32.2	0.1	
Total %	4.2	26.8	2.5	0	3.3	8.6	4.3	0	4.1	27	2.8	0	2.4	8.8	5.3	0	
Unshifted	471	3011	277	0	357	963	496	0	438	3053	297	0	268	990	575	1	11197
% Unshifted	97.5	96.5	96.5	0	94.2	96.8	98.4	0	92.4	97.2	92.8	0	97.5	96.3	93	100	96.3
Bank 1	12	108	10	0	22	32	8	0	36	88	23	0	7	38	43	0	427
% Bank 1	2.5	3.5	3.5	0	5.8	3.2	1.6	0	7.6	2.8	7.2	0	2.5	3.7	7	0	3.7

Alliant Engineering Inc Minneapolis, MN 55415

TH-3 at Cliff Rd / CSAH-32
 Ref.Pt.: 036.776
 Alliant Engineering Inc
 TURN MOVEMENT COUNT

File Name : 20_TH 3 at Cliff Rd_022410
 Site Code : 00000020
 Start Date : 2/24/2010
 Page No : 3

Start Time	Robert Trail S (TH-3) Southbound					Cliff Rd (Co Rd 32) Westbound					Robert Trail S (TH-3) Northbound					Cliff Rd (Co Rd 32) Eastbound					Int. Total
	Left	Thru	Right	Peds	App. Total	Left	Thru	Right	Peds	App. Total	Left	Thru	Right	Peds	App. Total	Left	Thru	Right	Peds	App. Total	
Peak Hour Analysis From 06:30 to 09:15 - Peak 1 of 1																					
Peak Hour for Entire Intersection Begins at 07:00																					
07:00	7	39	1	0	47	32	38	35	0	105	12	205	9	0	226	4	15	13	0	32	410
07:15	4	42	6	0	52	25	42	34	0	101	22	194	8	0	224	17	17	15	0	49	426
07:30	9	39	5	0	53	12	50	40	0	102	21	177	15	0	213	13	25	12	0	50	418
07:45	6	60	2	0	68	13	50	41	0	104	12	240	12	0	264	18	27	16	0	61	497
Total Volume	26	180	14	0	220	82	180	150	0	412	67	816	44	0	927	52	84	56	0	192	1751
% App. Total	11.8	81.8	6.4	0		19.9	43.7	36.4	0		7.2	88	4.7	0		27.1	43.8	29.2	0		
PHF	.722	.750	.583	.000	.809	.641	.900	.915	.000	.981	.761	.850	.733	.000	.878	.722	.778	.875	.000	.787	.881

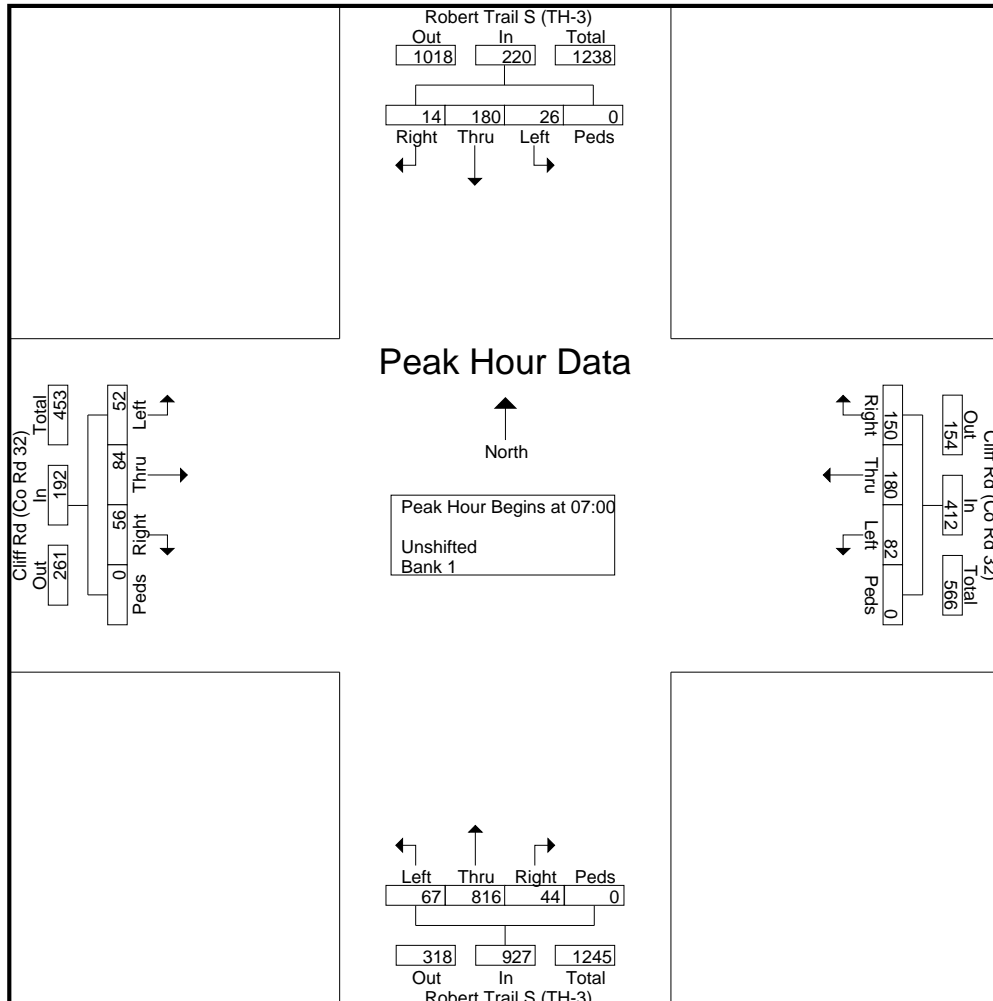

Alliant Engineering Inc Minneapolis, MN 55415

TH-3 at Cliff Rd / CSAH-32
 Ref.Pt.: 036.776
 Alliant Engineering Inc
 TURN MOVEMENT COUNT

File Name : 20_TH 3 at Cliff Rd_022410
 Site Code : 00000020
 Start Date : 2/24/2010
 Page No : 4

Start Time	Robert Trail S (TH-3) Southbound					Cliff Rd (Co Rd 32) Westbound					Robert Trail S (TH-3) Northbound					Cliff Rd (Co Rd 32) Eastbound					Int. Total
	Left	Thru	Right	Peds	App. Total	Left	Thru	Right	Peds	App. Total	Left	Thru	Right	Peds	App. Total	Left	Thru	Right	Peds	App. Total	
Peak Hour Analysis From 15:00 to 17:45 - Peak 1 of 1																					
Peak Hour for Entire Intersection Begins at 16:45																					
16:45	28	208	8	0	244	15	18	9	0	42	16	60	10	0	86	12	42	30	0	84	456
17:00	36	194	9	0	239	11	40	7	0	58	7	51	7	0	65	10	51	19	0	80	442
17:15	29	232	11	0	272	14	41	13	0	68	10	46	12	0	68	18	63	32	0	113	521
17:30	39	188	22	0	249	24	36	7	0	67	10	70	16	0	96	7	50	26	0	83	495
Total Volume	132	822	50	0	1004	64	135	36	0	235	43	227	45	0	315	47	206	107	0	360	1914
% App. Total	13.1	81.9	5	0		27.2	57.4	15.3	0		13.7	72.1	14.3	0		13.1	57.2	29.7	0		
PHF	.846	.886	.568	.000	.923	.667	.823	.692	.000	.864	.672	.811	.703	.000	.820	.653	.817	.836	.000	.796	.918

