



MINNESOTA DEPT OF TRANSPORTATION

TRAFFIC DATA COLLECTION - METRO

Location: TH 3 AT TH 149 2008
 Ref.Pt.: 038.332
 JAMAR# 632 DR
 TURN MOVEMENT COUNT

File Name : Not Named 3
 Site Code : 00000000
 Start Date : 4/17/2008
 Page No : 1

Groups Printed- Unshifted

Start Time	TH 149 Southbound				TH 3 Westbound				TH 149 Northbound				TH 3 Eastbound				Int. Total
	Left	Thru	Right	Peds	Left	Thru	Right	Peds	Left	Thru	Right	Peds	Left	Thru	Right	Peds	
06:00	0	0	2	0	0	9	0	0	0	0	0	0	68	27	0	0	106
06:15	1	0	9	0	0	15	1	0	0	0	0	0	81	53	0	0	160
06:30	0	0	21	0	0	23	1	0	0	0	0	0	98	84	0	0	227
06:45	1	0	26	0	0	49	3	0	0	0	0	0	158	71	0	0	308
Total	2	0	58	0	0	96	5	0	0	0	0	0	405	235	0	0	801
07:00	0	0	26	0	0	46	4	0	0	0	0	0	182	129	0	0	387
07:15	3	0	25	0	0	36	7	0	0	0	0	0	255	141	0	0	467
07:30	0	0	27	0	0	52	1	0	0	0	0	0	257	195	0	0	532
07:45	3	0	50	0	0	60	4	0	0	0	0	0	236	139	0	0	492
Total	6	0	128	0	0	194	16	0	0	0	0	0	930	604	0	0	1878
08:00	0	0	45	0	0	44	2	0	0	0	0	0	199	112	0	0	402
08:15	3	0	40	0	0	42	0	0	0	0	0	0	140	79	0	0	304
08:30	0	0	39	0	0	36	4	0	0	0	0	0	100	74	0	0	253
08:45	0	0	50	0	0	22	6	0	0	0	0	0	83	66	0	0	227
Total	3	0	174	0	0	144	12	0	0	0	0	0	522	331	0	0	1186
*** BREAK ***																	
15:00	1	0	82	0	0	62	5	0	0	0	0	0	39	61	0	0	250
15:15	3	0	88	0	0	82	2	0	0	0	0	0	55	54	0	0	284
15:30	1	0	115	0	0	96	1	0	0	0	0	0	43	53	0	0	309
15:45	4	0	123	0	0	73	5	0	0	0	0	0	50	75	0	0	330
Total	9	0	408	0	0	313	13	0	0	0	0	0	187	243	0	0	1173
16:00	1	0	139	0	0	94	1	0	0	0	0	0	43	61	0	0	339
16:15	2	0	168	0	0	103	1	0	0	0	0	0	50	43	0	0	367
16:30	4	0	196	0	0	108	1	0	0	0	0	0	60	45	0	0	414
16:45	7	0	186	0	0	138	2	0	0	0	0	0	62	54	0	0	449
Total	14	0	689	0	0	443	5	0	0	0	0	0	215	203	0	0	1569
17:00	4	0	209	0	0	115	2	0	0	0	0	0	85	70	0	0	485
17:15	2	0	181	0	0	141	3	0	0	0	0	0	97	66	0	0	490
17:30	10	0	199	0	0	151	0	0	0	0	0	0	66	67	0	0	493
17:45	2	0	120	0	0	114	0	0	0	0	0	0	49	73	0	0	358
Total	18	0	709	0	0	521	5	0	0	0	0	0	297	276	0	0	1826
Grand Total	52	0	2166	0	0	1711	56	0	0	0	0	0	2556	1892	0	0	8433
Apprch %	2.3	0	97.7	0	0	96.8	3.2	0	0	0	0	0	57.5	42.5	0	0	
Total %	0.6	0	25.7	0	0	20.3	0.7	0	0	0	0	0	30.3	22.4	0	0	



MINNESOTA DEPT OF TRANSPORTATION

TRAFFIC DATA COLLECTION - METRO

Location: TH 3 AT TH 149 2008
 Ref.Pt.: 038.332
 JAMAR# 632 DR
 TURN MOVEMENT COUNT

File Name : Not Named 3
 Site Code : 00000000
 Start Date : 4/17/2008
 Page No : 2

Start Time	TH 149 Southbound					TH 3 Westbound					TH 149 Northbound					TH 3 Eastbound					Int. Total
	Left	Thru	Right	Peds	App. Total	Left	Thru	Right	Peds	App. Total	Left	Thru	Right	Peds	App. Total	Left	Thru	Right	Peds	App. Total	
Peak Hour Analysis From 06:00 to 08:45 - Peak 1 of 1																					
Peak Hour for Entire Intersection Begins at 07:15																					
07:15	3	0	25	0	28	0	36	7	0	43	0	0	0	0	0	255	141	0	0	396	467
07:30	0	0	27	0	27	0	52	1	0	53	0	0	0	0	0	257	195	0	0	452	532
07:45	3	0	50	0	53	0	60	4	0	64	0	0	0	0	0	236	139	0	0	375	492
08:00	0	0	45	0	45	0	44	2	0	46	0	0	0	0	0	199	112	0	0	311	402
Total Volume	6	0	147	0	153	0	192	14	0	206	0	0	0	0	0	947	587	0	0	1534	1893
% App. Total																					
PHF	.500	.000	.735	.000	.722	.000	.800	.500	.000	.805	.000	.000	.000	.000	.000	.921	.753	.000	.000	.848	.890

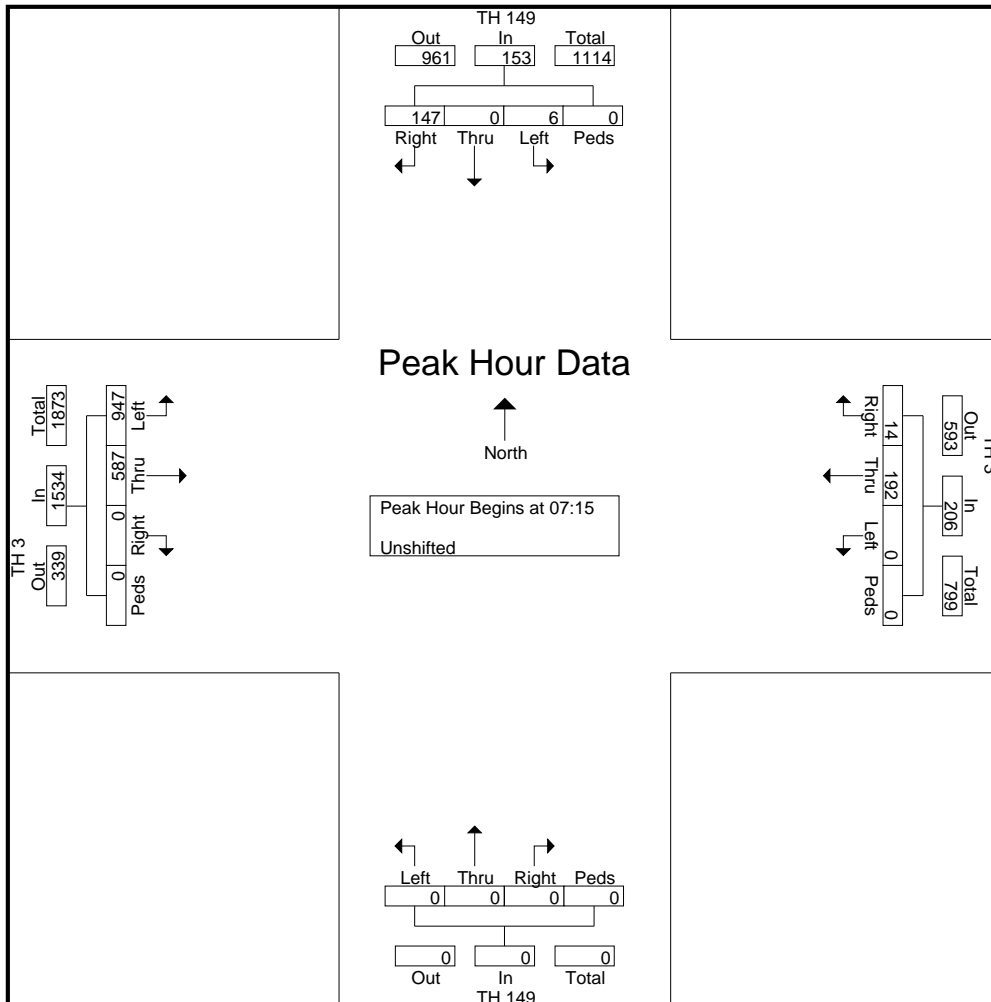



MINNESOTA DEPT OF TRANSPORTATION

TRAFFIC DATA COLLECTION - METRO

Location: TH 3 AT TH 149 2008
 Ref.Pt.: 038.332
 JAMAR# 632 DR
 TURN MOVEMENT COUNT

File Name : Not Named 3
 Site Code : 00000000
 Start Date : 4/17/2008
 Page No : 3

Start Time	TH 149 Southbound					TH 3 Westbound					TH 149 Northbound					TH 3 Eastbound					Int. Total
	Left	Thru	Right	Peds	App. Total	Left	Thru	Right	Peds	App. Total	Left	Thru	Right	Peds	App. Total	Left	Thru	Right	Peds	App. Total	
Peak Hour Analysis From 15:00 to 17:45 - Peak 1 of 1																					
Peak Hour for Entire Intersection Begins at 16:45																					
16:45	7	0	186	0	193	0	138	2	0	140	0	0	0	0	0	62	54	0	0	116	449
17:00	4	0	209	0	213	0	115	2	0	117	0	0	0	0	0	85	70	0	0	155	485
17:15	2	0	181	0	183	0	141	3	0	144	0	0	0	0	0	97	66	0	0	163	490
17:30	10	0	199	0	209	0	151	0	0	151	0	0	0	0	0	66	67	0	0	133	493
Total Volume	23	0	775	0	798	0	545	7	0	552	0	0	0	0	0	310	257	0	0	567	1917
% App. Total																					
PHF	.575	.000	.927	.000	.937	.000	.902	.583	.000	.914	.000	.000	.000	.000	.000	.799	.918	.000	.000	.870	.972

