



# MINNESOTA DEPT OF TRANSPORTATION

TRAFFIC DATA COLLECTION - METRO

TH-952 / ROBERT ST. AT BERNARD St/ile Name : TH-952 ROBERT ST AT BERNARD ST 2006

REF.PT.: 129.257

Site Code : 00000000

JAMAR# 631 RE

Start Date : 3/1/2006

TURN MOVEMENT COUNT

Page No : 1

Groups Printed- Cars & Trucks

Start Time	TH-952 Robert St. Southbound				Bernard St. Westbound				TH-952 Robert St Northbound				Bernard St. Eastbound				Int. Total
	Left	Thru	Right	Peds	Left	Thru	Right	Peds	Left	Thru	Right	Peds	Left	Thru	Right	Peds	
06:00	0	25	1	0	0	0	2	0	4	33	0	0	1	2	2	0	70
06:15	1	27	1	0	0	3	6	0	2	55	0	0	3	2	7	0	107
06:30	1	36	2	0	0	2	8	0	1	101	0	0	4	8	2	0	165
06:45	1	56	1	0	3	5	10	0	2	105	1	1	1	1	6	0	193
Total	3	144	5	0	3	10	26	0	9	294	1	1	9	13	17	0	535
07:00	1	58	0	1	8	10	2	0	4	99	0	0	7	6	9	0	205
07:15	1	78	0	0	4	12	9	0	4	116	2	1	3	3	10	0	243
07:30	1	83	1	1	3	7	4	0	7	151	1	0	4	15	10	0	288
07:45	1	79	2	1	8	6	6	0	4	160	1	1	7	2	5	0	283
Total	4	298	3	3	23	35	21	0	19	526	4	2	21	26	34	0	1019
08:00	1	65	2	0	2	8	1	1	4	106	2	0	2	3	11	0	208
08:15	0	72	0	0	2	9	6	0	4	119	2	0	3	9	8	0	234
08:30	0	71	2	0	2	6	7	0	6	107	2	0	1	9	7	0	220
08:45	4	79	4	0	1	8	3	0	9	116	3	1	2	6	7	0	243
Total	5	287	8	0	7	31	17	1	23	448	9	1	8	27	33	0	905
10:45	1	120	1	1	0	3	7	0	7	115	1	0	3	5	9	0	273
Total	1	120	1	1	0	3	7	0	7	115	1	0	3	5	9	0	273
11:00	2	134	1	0	1	5	3	0	11	125	2	1	3	3	12	0	303
11:15	1	135	2	1	3	0	5	0	11	134	4	0	4	4	13	1	318
11:30	1	148	2	2	6	5	5	0	8	113	0	0	1	6	7	0	304
11:45	1	172	2	1	3	3	4	0	3	160	3	0	2	2	9	0	365
Total	5	589	7	4	13	13	17	0	33	532	9	1	10	15	41	1	1290
12:00	1	178	2	1	1	3	2	0	5	145	3	0	1	3	11	0	356
12:15	3	138	1	0	2	2	3	0	10	191	3	0	0	2	6	0	361
12:30	7	136	5	0	2	3	1	0	6	143	1	1	4	4	9	0	322
12:45	4	149	0	0	4	3	3	0	5	184	4	0	5	6	13	0	380
Total	15	601	8	1	9	11	9	0	26	663	11	1	10	15	39	0	1419
14:30	3	126	0	0	4	7	3	0	11	134	3	2	3	3	12	1	312
14:45	3	142	7	3	1	3	2	0	10	151	4	0	4	9	10	1	350
Total	6	268	7	3	5	10	5	0	21	285	7	2	7	12	22	2	662
15:00	5	131	1	1	4	8	2	1	11	155	6	0	0	9	11	1	346
15:15	3	132	4	2	6	6	6	1	14	122	14	3	4	14	14	0	345
15:30	3	164	3	1	5	11	4	0	8	134	3	0	2	8	14	1	361
15:45	3	182	2	1	6	16	3	3	6	152	6	1	5	7	13	0	406
Total	14	609	10	5	21	41	15	5	39	563	29	4	11	38	52	2	1458
16:00	3	174	7	1	5	3	0	0	11	156	3	1	1	6	14	1	386
16:15	1	196	4	1	9	12	6	0	15	155	7	1	1	6	13	1	428
16:30	7	195	2	0	1	8	7	1	12	180	5	3	5	11	18	0	455
16:45	4	209	8	0	7	13	5	0	11	156	6	1	4	15	9	0	448
Total	15	774	21	2	22	36	18	1	49	647	21	6	11	38	54	2	1717
17:00	1	189	6	0	8	13	4	2	13	179	5	1	7	12	11	2	453
17:15	3	213	4	2	4	8	3	0	19	177	2	1	1	8	15	0	460
17:30	5	189	3	4	5	4	3	0	5	150	2	2	5	7	16	0	400
17:45	3	179	3	0	7	8	3	0	13	175	4	0	6	8	13	2	424
Total	12	770	16	6	24	33	13	2	50	681	13	4	19	35	55	4	1737



# MINNESOTA DEPT OF TRANSPORTATION

TRAFFIC DATA COLLECTION - METRO

TH-952 / ROBERT ST. AT BERNARD ST File Name : TH-952 ROBERT ST AT BERNARD ST 2006

REF.PT.: 129.257

Site Code : 00000000

JAMAR# 631 RE

Start Date : 3/1/2006

TURN MOVEMENT COUNT

Page No : 2

**Groups Printed- Cars & Trucks**

	TH-952 Robert St. Southbound				Bernard St. Westbound				TH-952 Robert St Northbound				Bernard St. Eastbound				Int. Total
	Left	Thru	Right	Peds	Left	Thru	Right	Peds	Left	Thru	Right	Peds	Left	Thru	Right	Peds	
Grand Total	80	4460	86	25	127	223	148	9	276	4754	105	22	109	224	356	11	11015
Apprch %	1.7	95.9	1.8	0.5	25	44	29.2	1.8	5.4	92.2	2	0.4	15.6	32	50.9	1.6	
Total %	0.7	40.5	0.8	0.2	1.2	2	1.3	0.1	2.5	43.2	1	0.2	1	2	3.2	0.1	



# MINNESOTA DEPT OF TRANSPORTATION

TRAFFIC DATA COLLECTION - METRO

TH-952 / ROBERT ST. AT BERNARD ST File Name : TH-952 ROBERT ST AT BERNARD ST 2006

REF.PT.: 129.257

Site Code : 00000000

JAMAR# 631 RE

Start Date : 3/1/2006

TURN MOVEMENT COUNT

Page No : 3

Start Time	TH-952 Robert St. Southbound					Bernard St. Westbound					TH-952 Robert St Northbound					Bernard St. Eastbound					Int. Total
	Left	Thru	Right	Peds	App. Total	Left	Thru	Right	Peds	App. Total	Left	Thru	Right	Peds	App. Total	Left	Thru	Right	Peds	App. Total	
Peak Hour Analysis From 06:00 to 08:45 - Peak 1 of 1																					
Peak Hour for Entire Intersection Begins at 07:15																					
07:15	1	78	0	0	79	4	12	9	0	25	4	116	2	1	123	3	3	10	0	16	243
07:30	1	83	1	1	86	3	7	4	0	14	7	151	1	0	159	4	15	10	0	29	288
07:45	1	79	2	1	83	8	6	6	0	20	4	160	1	1	166	7	2	5	0	14	283
08:00	1	65	2	0	68	2	8	1	1	12	4	106	2	0	112	2	3	11	0	16	208
Total Volume	4	305	5	2	316	17	33	20	1	71	19	533	6	2	560	16	23	36	0	75	1022
% App. Total	1.3	96.5	1.6	0.6		23.9	46.5	28.2	1.4		3.4	95.2	1.1	0.4		21.3	30.7	48	0		
PHF	1.000	.919	.625	.500	.919	.531	.688	.556	.250	.710	.679	.833	.750	.500	.843	.571	.383	.818	.000	.647	.887

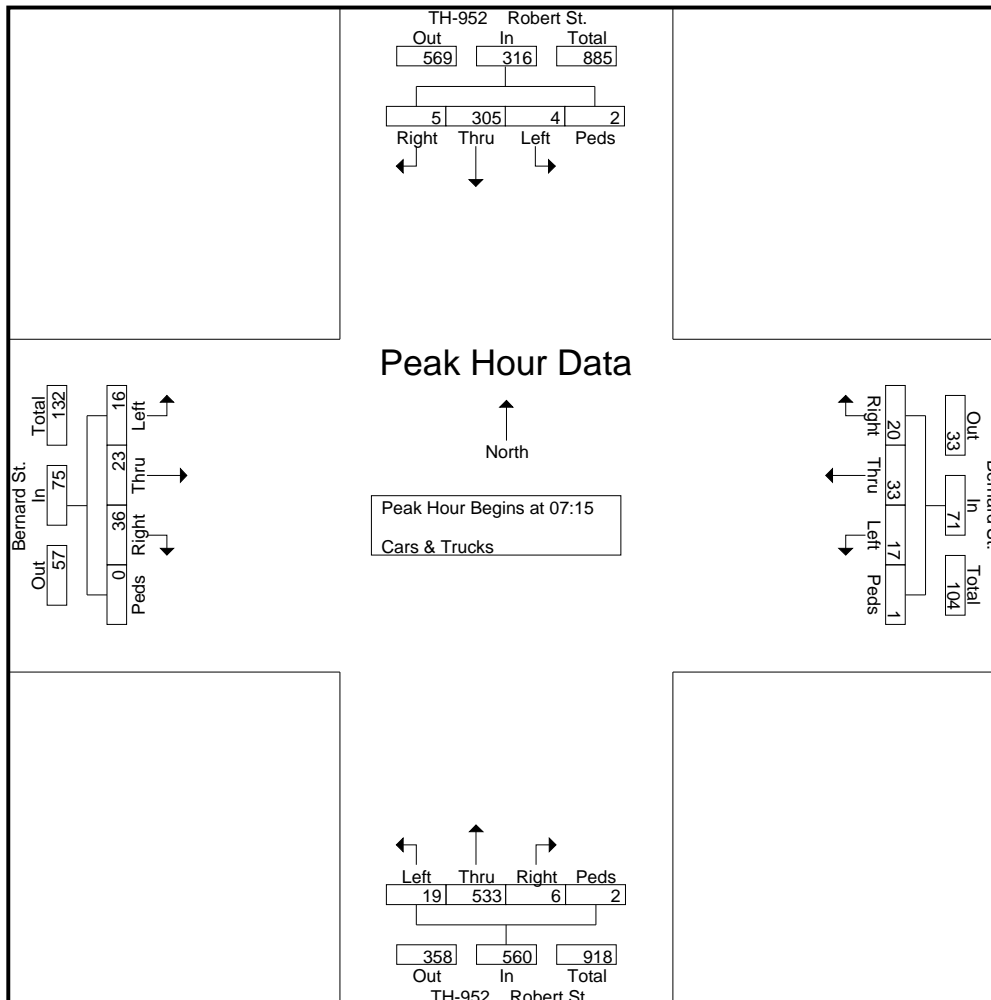



# MINNESOTA DEPT OF TRANSPORTATION

TRAFFIC DATA COLLECTION - METRO

TH-952 / ROBERT ST. AT BERNARD ST File Name : TH-952 ROBERT ST AT BERNARD ST 2006

REF.PT.: 129.257

Site Code : 00000000

JAMAR# 631 RE

Start Date : 3/1/2006

TURN MOVEMENT COUNT

Page No : 4

Start Time	TH-952 Robert St. Southbound					Bernard St. Westbound					TH-952 Robert St Northbound					Bernard St. Eastbound					Int. Total
	Left	Thru	Right	Peds	App. Total	Left	Thru	Right	Peds	App. Total	Left	Thru	Right	Peds	App. Total	Left	Thru	Right	Peds	App. Total	
Peak Hour Analysis From 15:00 to 17:45 - Peak 1 of 1																					
Peak Hour for Entire Intersection Begins at 16:30																					
16:30	7	195	2	0	204	1	8	7	1	17	12	180	5	3	200	5	11	18	0	34	455
16:45	4	209	8	0	221	7	13	5	0	25	11	156	6	1	174	4	15	9	0	28	448
17:00	1	189	6	0	196	8	13	4	2	27	13	179	5	1	198	7	12	11	2	32	453
17:15	3	213	4	2	222	4	8	3	0	15	19	177	2	1	199	1	8	15	0	24	460
Total Volume	15	806	20	2	843	20	42	19	3	84	55	692	18	6	771	17	46	53	2	118	1816
% App. Total	1.8	95.6	2.4	0.2		23.8	50	22.6	3.6		7.1	89.8	2.3	0.8		14.4	39	44.9	1.7		
PHF	.536	.946	.625	.250	.949	.625	.808	.679	.375	.778	.724	.961	.750	.500	.964	.607	.767	.736	.250	.868	.987

