



MINNESOTA DEPT OF TRANSPORTATION

TRAFFIC DATA COLLECTION - METRO

TH-41 at Lyman Blvd / CSAH-18

File Name : TH-41 at Lyman Blvd CSAH-18 2008

Ref.Pt.: 006.230

Site Code : 05042711

Data by: Westwood Professional Services

Start Date : 9/11/2008

TURN MOVEMENT COUNT

Page No : 1

Groups Printed- Unshifted

Start Time	Lyman Blvd. Southbound				TH-41 Westbound				Lyman Blvd. Northbound				TH-41 Eastbound				Int. Total
	Left	Thru	Right	Peds	Left	Thru	Right	Peds	Left	Thru	Right	Peds	Left	Thru	Right	Peds	
06:00	10	42	26	0	8	1	3	0	29	48	22	0	1	1	2	0	193
06:15	7	34	28	0	3	0	2	0	27	84	30	0	0	2	2	0	219
06:30	7	53	10	0	4	0	4	0	18	85	51	0	24	5	26	0	287
06:45	10	76	11	0	17	1	1	0	26	78	66	0	1	1	7	0	295
Total	34	205	75	0	32	2	10	0	100	295	169	0	26	9	37	0	994
07:00	12	89	21	0	53	1	1	0	18	104	29	0	3	1	0	0	332
07:15	19	92	24	0	34	2	4	0	17	139	50	0	2	1	0	0	384
07:30	27	111	23	0	39	0	6	1	25	164	41	0	0	2	1	0	440
07:45	40	137	24	0	19	1	8	0	28	169	76	0	0	3	1	0	506
Total	98	429	92	0	145	4	19	1	88	576	196	0	5	7	2	0	1662
08:00	18	88	28	0	11	1	3	0	32	140	67	0	2	2	2	0	394
08:15	7	96	19	0	11	2	3	0	13	132	28	0	1	1	0	0	313
08:30	15	87	14	0	12	0	0	0	4	206	45	0	4	1	0	0	388
08:45	12	92	6	0	24	0	2	0	14	158	26	0	0	2	3	0	339
Total	52	363	67	0	58	3	8	0	63	636	166	0	7	6	5	0	1434
*** BREAK ***																	
10:45	11	83	7	0	0	0	0	0	0	0	0	0	3	5	7	0	116
Total	11	83	7	0	0	0	0	0	0	0	0	0	3	5	7	0	116
11:00	6	87	5	0	21	1	12	0	5	88	16	0	9	5	10	0	265
11:15	5	87	5	0	27	2	4	0	5	103	15	0	20	4	10	0	287
11:30	6	103	7	0	27	0	10	0	3	93	18	0	9	1	18	0	295
11:45	2	112	8	0	33	2	6	0	11	100	13	0	10	6	19	0	322
Total	19	389	25	0	108	5	32	0	24	384	62	0	48	16	57	0	1169
12:00	3	122	4	0	40	4	5	0	11	93	14	0	5	6	10	0	317
12:15	7	97	9	0	20	5	3	0	9	106	35	0	5	3	17	0	316
12:30	6	162	13	0	19	3	5	0	20	101	29	0	5	1	8	0	372
12:45	7	130	11	0	20	6	7	0	25	99	30	0	5	2	13	0	355
Total	23	511	37	0	99	18	20	0	65	399	108	0	20	12	48	0	1360
*** BREAK ***																	
14:45	10	139	1	0	0	0	0	0	0	0	0	0	5	2	8	0	165
Total	10	139	1	0	0	0	0	0	0	0	0	0	5	2	8	0	165
15:00	9	103	3	0	101	2	15	1	2	129	26	0	5	5	4	0	405
15:15	3	121	2	0	57	0	17	0	5	99	30	0	9	0	28	1	372
15:30	3	116	5	0	75	2	20	0	8	126	31	0	14	1	10	0	411
15:45	2	132	4	0	53	1	19	0	8	109	24	0	19	4	16	0	391
Total	17	472	14	0	286	5	71	1	23	463	111	0	47	10	58	1	1579
16:00	5	125	9	0	66	3	15	0	2	117	12	0	16	2	24	0	396
16:15	5	141	0	0	51	1	19	1	10	145	17	0	38	8	45	0	481
16:30	1	92	0	0	70	1	13	0	3	130	14	0	25	9	21	0	379
16:45	3	165	1	0	42	1	15	0	4	129	17	0	24	7	26	0	434
Total	14	523	10	0	229	6	62	1	19	521	60	0	103	26	116	0	1690
17:00	0	176	0	0	63	3	5	0	2	133	29	0	17	2	22	0	452
17:15	2	124	0	0	58	1	4	0	1	125	22	0	20	2	17	0	376
17:30	0	126	2	0	46	0	9	0	4	145	23	0	8	1	4	0	368
17:45	1	125	1	0	27	1	5	0	10	130	33	0	14	2	11	0	360
Total	3	551	3	0	194	5	23	0	17	533	107	0	59	7	54	0	1556



MINNESOTA DEPT OF TRANSPORTATION

TRAFFIC DATA COLLECTION - METRO

TH-41 at Lyman Blvd / CSAH-18
 Ref.Pt.: 006.230
 Data by: Westwood Professional Services
 TURN MOVEMENT COUNT

File Name : TH-41 at Lyman Blvd CSAH-18 2008
 Site Code : 05042711
 Start Date : 9/11/2008
 Page No : 2

Groups Printed- Unshifted

	Lyman Blvd. Southbound				TH-41 Westbound				Lyman Blvd. Northbound				TH-41 Eastbound				Int. Total
	Left	Thru	Right	Peds	Left	Thru	Right	Peds	Left	Thru	Right	Peds	Left	Thru	Right	Peds	
Grand Total	281	3665	331	0	1151	48	245	3	399	3807	979	0	323	100	392	1	11725
Apprch %	6.6	85.7	7.7	0	79.5	3.3	16.9	0.2	7.7	73.4	18.9	0	39.6	12.3	48	0.1	
Total %	2.4	31.3	2.8	0	9.8	0.4	2.1	0	3.4	32.5	8.3	0	2.8	0.9	3.3	0	



MINNESOTA DEPT OF TRANSPORTATION

TRAFFIC DATA COLLECTION - METRO

TH-41 at Lyman Blvd / CSAH-18
 Ref.Pt.: 006.230
 Data by: Westwood Professional Services
 TURN MOVEMENT COUNT

File Name : TH-41 at Lyman Blvd CSAH-18 2008
 Site Code : 05042711
 Start Date : 9/11/2008
 Page No : 3

Start Time	Lyman Blvd. Southbound					TH-41 Westbound					Lyman Blvd. Northbound					TH-41 Eastbound					Int. Total
	Left	Thru	Right	Peds	App. Total	Left	Thru	Right	Peds	App. Total	Left	Thru	Right	Peds	App. Total	Left	Thru	Right	Peds	App. Total	
Peak Hour Analysis From 06:00 to 08:45 - Peak 1 of 1																					
Peak Hour for Entire Intersection Begins at 07:15																					
07:15	19	92	24	0	135	34	2	4	0	40	17	139	50	0	206	2	1	0	0	3	384
07:30	27	111	23	0	161	39	0	6	1	46	25	164	41	0	230	0	2	1	0	3	440
07:45	40	137	24	0	201	19	1	8	0	28	28	169	76	0	273	0	3	1	0	4	506
08:00	18	88	28	0	134	11	1	3	0	15	32	140	67	0	239	2	2	2	0	6	394
Total Volume	104	428	99	0	631	103	4	21	1	129	102	612	234	0	948	4	8	4	0	16	1724
% App. Total	16.5	67.8	15.7	0		79.8	3.1	16.3	0.8		10.8	64.6	24.7	0		25	50	25	0		
PHF	.650	.781	.884	.000	.785	.660	.500	.656	.250	.701	.797	.905	.770	.000	.868	.500	.667	.500	.000	.667	.852

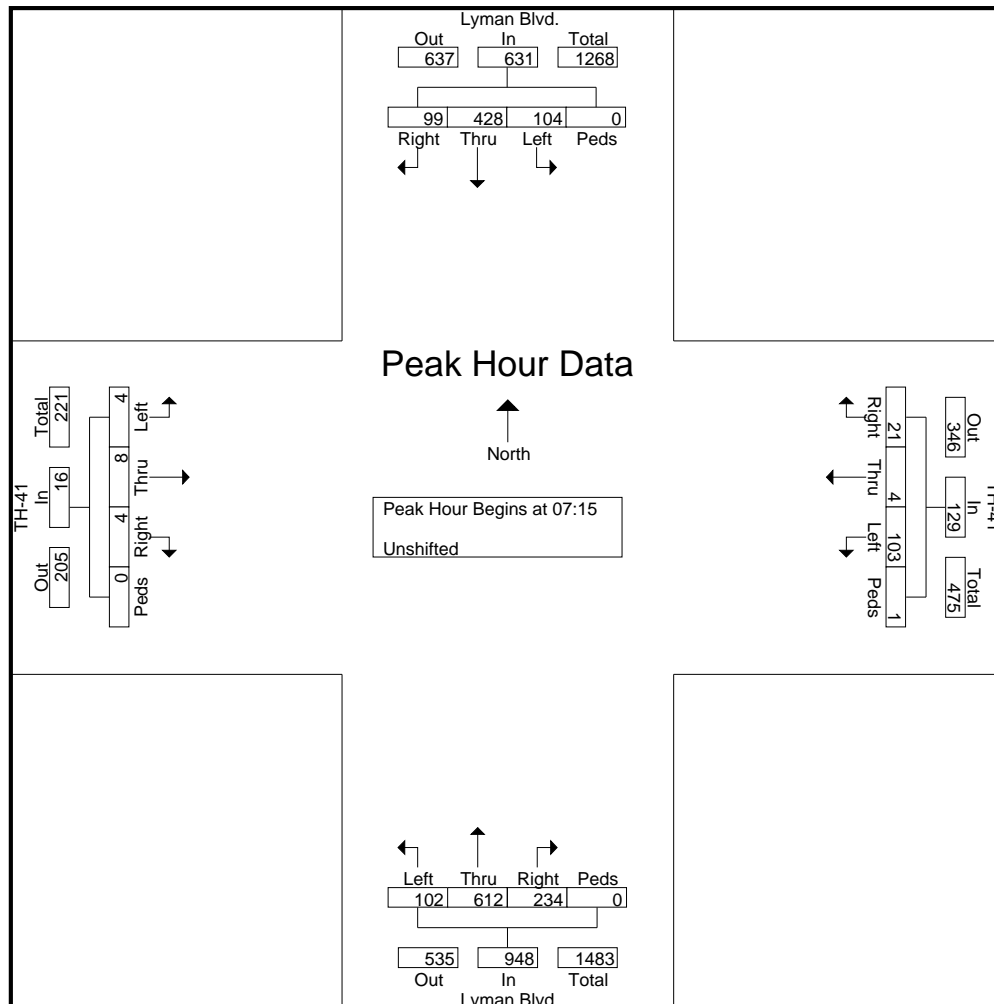



MINNESOTA DEPT OF TRANSPORTATION

TRAFFIC DATA COLLECTION - METRO

TH-41 at Lyman Blvd / CSAH-18
 Ref.Pt.: 006.230
 Data by: Westwood Professional Services
 TURN MOVEMENT COUNT

File Name : TH-41 at Lyman Blvd CSAH-18 2008
 Site Code : 05042711
 Start Date : 9/11/2008
 Page No : 4

Start Time	Lyman Blvd. Southbound					TH-41 Westbound					Lyman Blvd. Northbound					TH-41 Eastbound					Int. Total
	Left	Thru	Right	Peds	App. Total	Left	Thru	Right	Peds	App. Total	Left	Thru	Right	Peds	App. Total	Left	Thru	Right	Peds	App. Total	

Peak Hour Analysis From 15:00 to 17:45 - Peak 1 of 1

Peak Hour for Entire Intersection Begins at 16:15

16:15	5	141	0	0	146	51	1	19	1	72	10	145	17	0	172	38	8	45	0	91	481
16:30	1	92	0	0	93	70	1	13	0	84	3	130	14	0	147	25	9	21	0	55	379
16:45	3	165	1	0	169	42	1	15	0	58	4	129	17	0	150	24	7	26	0	57	434
17:00	0	176	0	0	176	63	3	5	0	71	2	133	29	0	164	17	2	22	0	41	452
Total Volume	9	574	1	0	584	226	6	52	1	285	19	537	77	0	633	104	26	114	0	244	1746
% App. Total	1.5	98.3	0.2	0		79.3	2.1	18.2	0.4		3	84.8	12.2	0		42.6	10.7	46.7	0		
PHF	.450	.815	.250	.000	.830	.807	.500	.684	.250	.848	.475	.926	.664	.000	.920	.684	.722	.633	.000	.670	.907

