

MN Dept of Transportation

TRAFFIC DATA COLLECTION - Metro

TH-41 at Minnetonka Middle School entran
 Ref.Pt. 009.085
 video AL / RE
 TURN MOVEMENT COUNT

File Name : TH-41 at Minnetonka Middle School 2015
 Site Code :
 Start Date : 10/27/2015
 Page No : 1

Groups Printed- Cars +

Start Time	TH-41 Southbound				School entrance Westbound				TH-41 Northbound				driveway Eastbound				Int. Total
	Left	Thru	Right	Peds	Left	Thru	Right	Peds	Left	Thru	Right	Peds	Left	Thru	Right	Peds	
06:00	0	35	0	0	0	0	0	0	0	0	60	1	0	0	0	0	96
06:15	0	84	0	0	0	0	0	0	0	0	61	1	0	0	0	0	146
06:30	3	91	0	0	0	0	0	0	0	0	172	1	0	0	0	0	267
06:45	0	182	0	0	0	0	0	0	0	0	158	0	0	0	0	0	340
Total	3	392	0	0	0	0	0	0	0	0	451	3	0	0	0	0	849
07:00	3	136	1	0	0	0	2	0	0	0	166	1	0	0	0	0	309
07:15	11	163	1	0	2	0	2	0	0	0	164	1	0	0	0	0	344
07:30	21	187	0	0	3	0	20	0	0	0	188	6	0	0	0	0	425
07:45	31	209	0	0	9	0	18	3	0	0	154	15	0	0	1	0	440
Total	66	695	2	0	14	0	42	3	0	0	672	23	0	0	1	0	1518
08:00	29	257	0	0	7	0	14	0	0	0	289	19	0	0	0	0	615
08:15	45	107	0	0	5	0	34	0	0	0	291	35	0	0	0	0	517
08:30	79	171	0	0	14	0	88	1	0	0	118	34	0	0	0	0	505
08:45	59	171	0	0	15	0	58	5	0	0	140	24	0	0	0	0	472
Total	212	706	0	0	41	0	194	6	0	0	838	112	0	0	0	0	2109
09:00	52	184	0	0	15	0	84	0	0	0	115	41	0	0	0	0	491
09:15	9	147	0	0	4	1	11	0	0	0	99	4	0	0	0	0	275
09:30	10	119	1	0	3	0	6	0	0	0	103	1	0	0	0	0	243
09:45	5	115	0	0	0	0	2	0	0	0	104	1	0	0	0	0	227
Total	76	565	1	0	22	1	103	0	0	0	421	47	0	0	0	0	1236
10:00	2	96	0	0	0	0	1	1	0	0	69	1	0	0	0	0	170
10:15	1	93	0	0	0	0	7	0	0	0	88	3	0	0	0	0	192
10:30	1	87	1	0	0	0	2	0	0	0	87	1	0	0	0	0	179
10:45	2	94	0	0	2	0	1	0	1	0	91	0	0	0	0	0	191
Total	6	370	1	0	2	0	11	1	1	1	335	5	0	0	0	0	732
11:00	4	68	0	0	0	0	5	1	0	0	92	2	0	1	0	0	173
11:15	7	74	0	0	1	0	4	0	0	0	127	0	0	5	0	0	218
11:30	4	92	0	0	2	0	6	0	0	0	90	0	0	0	0	0	194
11:45	0	79	0	0	1	0	2	0	0	0	98	4	0	0	0	0	184
Total	15	313	0	0	4	0	17	1	0	0	407	6	0	6	0	0	769
12:00	5	95	0	0	1	0	7	0	0	0	115	4	0	0	0	0	227
12:15	3	69	0	0	1	0	4	0	0	0	81	2	0	1	0	0	161
12:30	1	51	0	0	1	0	0	0	0	0	50	3	0	0	0	0	106
12:45	5	116	0	0	1	0	1	0	0	0	88	1	0	0	0	0	212
Total	14	331	0	0	4	0	12	0	0	0	334	10	0	1	0	0	706
13:00	5	96	0	0	1	0	8	0	0	0	98	1	0	0	0	0	209
13:15	3	84	0	0	1	0	4	0	0	0	91	1	0	0	0	0	184
13:30	3	96	1	0	1	0	2	0	0	0	87	2	0	0	0	0	192
13:45	2	90	0	0	0	0	4	0	0	0	73	2	0	0	0	0	171
Total	13	366	1	0	3	0	18	0	0	0	349	6	0	0	0	0	756
14:00	3	76	0	0	2	0	11	0	0	0	94	0	0	0	0	0	186
14:15	1	66	1	0	2	0	3	0	0	0	92	1	0	1	0	0	167
14:30	2	70	0	0	0	0	1	0	0	0	101	0	0	0	0	0	174
14:45	5	140	1	0	5	0	3	1	0	0	126	2	0	1	0	0	284
Total	11	352	2	0	9	0	18	1	0	0	413	3	0	2	0	0	811
15:00	2	133	0	0	2	0	4	0	0	0	150	3	0	2	0	0	296
15:15	9	94	1	0	3	0	1	0	0	0	139	3	0	1	0	0	251
15:30	25	123	0	0	1	0	8	0	0	0	175	13	0	0	0	0	345
15:45	62	132	0	0	3	0	9	1	0	0	193	26	0	0	0	0	426
Total	98	482	1	0	9	0	22	1	0	0	657	45	0	3	0	0	1318

MN Dept of Transportation

TRAFFIC DATA COLLECTION - Metro

TH-41 at Minnetonka Middle School entran
 Ref.Pt. 009.085
 video AL / RE
 TURN MOVEMENT COUNT

File Name : TH-41 at Minnetonka Middle School 2015
 Site Code :
 Start Date : 10/27/2015
 Page No : 2

Groups Printed- Cars +

Start Time	TH-41 Southbound				School entrance Westbound				TH-41 Northbound				driveway Eastbound				Int. Total	
	Left	Thru	Right	Peds	Left	Thru	Right	Peds	Left	Thru	Right	Peds	Left	Thru	Right	Peds		
16:00	47	142	0	0	34	1	70	0	0	189	20	0	0	0	0	0	0	503
16:15	29	136	0	0	20	0	61	1	0	204	14	0	0	0	0	0	0	465
16:30	16	135	0	0	12	0	22	0	0	217	11	0	0	0	0	0	0	413
16:45	10	169	0	0	7	0	18	0	0	228	10	0	0	0	0	0	0	442
Total	102	582	0	0	73	1	171	1	0	838	55	0	0	0	0	0	0	1823
17:00	9	157	0	0	6	0	16	0	0	210	7	0	0	0	0	0	0	405
17:15	28	162	0	0	8	0	40	2	0	232	17	0	0	0	0	0	0	489
17:30	20	143	0	0	15	0	25	2	0	184	18	0	0	0	0	0	0	407
17:45	22	137	0	0	16	0	43	1	0	160	14	0	0	0	0	0	0	393
Total	79	599	0	0	45	0	124	5	0	786	56	0	0	0	0	0	0	1694
Grand Total	695	5753	8	0	226	2	732	19	1	6501	371	0	12	0	1	0		14321
Apprch %	10.8	89.1	0.1	0	23.1	0.2	74.8	1.9	0	94.6	5.4	0	92.3	0	7.7	0		
Total %	4.9	40.2	0.1	0	1.6	0	5.1	0.1	0	45.4	2.6	0	0.1	0	0	0		

MN Dept of Transportation

TRAFFIC DATA COLLECTION - Metro

TH-41 at Minnetonka Middle School entran
 Ref.Pt. 009.085
 video AL / RE
 TURN MOVEMENT COUNT

File Name : TH-41 at Minnetonka Middle School 2015
 Site Code :
 Start Date : 10/27/2015
 Page No : 3

Start Time	TH-41 Southbound					School entrance Westbound					TH-41 Northbound					driveway Eastbound					Int. Total
	Left	Thru	Right	Peds	App. Total	Left	Thru	Right	Peds	App. Total	Left	Thru	Right	Peds	App. Total	Left	Thru	Right	Peds	App. Total	
Peak Hour Analysis From 06:00 to 11:45 - Peak 1 of 1																					
Peak Hour for Entire Intersection Begins at 08:00																					
08:00	29	257	0	0	286	7	0	14	0	21	0	289	19	0	308	0	0	0	0	0	615
08:15	45	107	0	0	152	5	0	34	0	39	0	291	35	0	326	0	0	0	0	0	517
08:30	79	171	0	0	250	14	0	88	1	103	0	118	34	0	152	0	0	0	0	0	505
08:45	59	171	0	0	230	15	0	58	5	78	0	140	24	0	164	0	0	0	0	0	472
Total Volume	212	706	0	0	918	41	0	194	6	241	0	838	112	0	950	0	0	0	0	0	2109
% App. Total	23.1	76.9	0	0		17	0	80.5	2.5		0	88.2	11.8	0		0	0	0	0		
PHF	.671	.687	.000	.000	.802	.683	.000	.551	.300	.585	.000	.720	.800	.000	.729	.000	.000	.000	.000	.000	.857

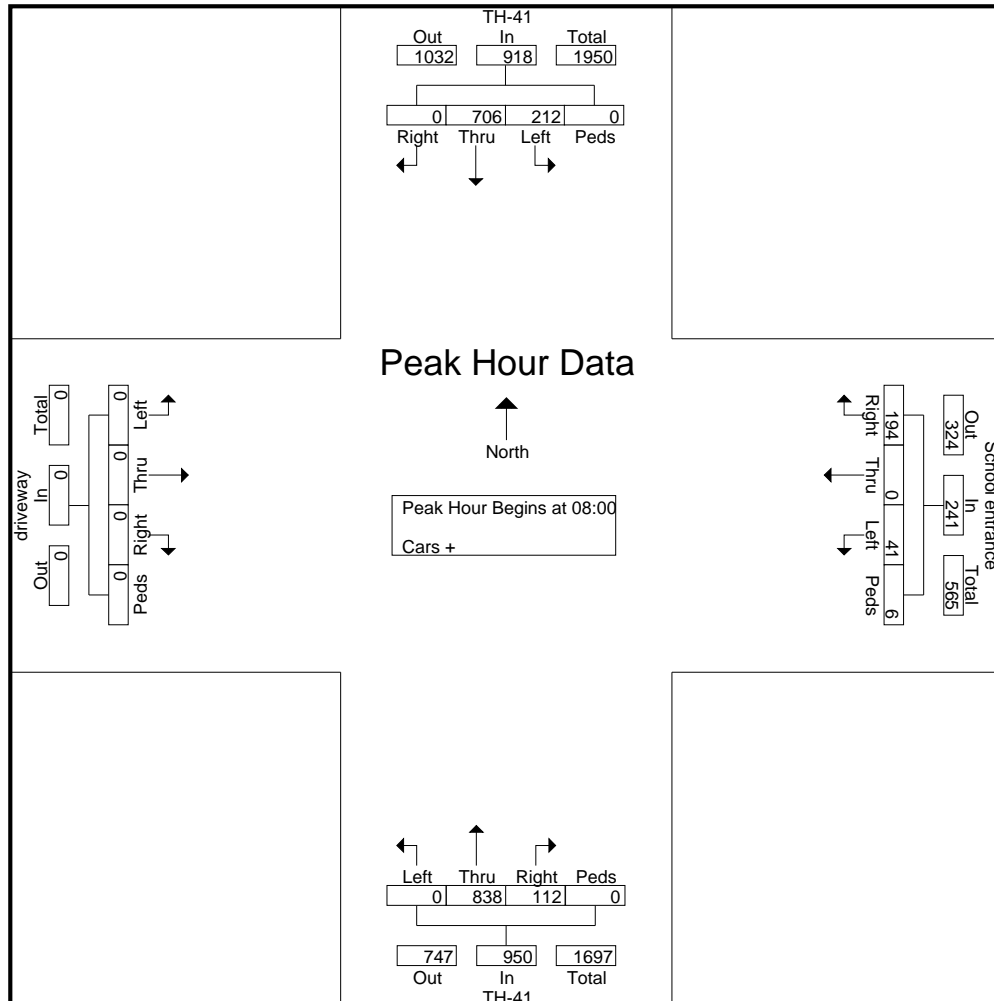

MN Dept of Transportation

TRAFFIC DATA COLLECTION - Metro

TH-41 at Minnetonka Middle School entran
 Ref.Pt. 009.085
 video AL / RE
 TURN MOVEMENT COUNT

File Name : TH-41 at Minnetonka Middle School 2015
 Site Code :
 Start Date : 10/27/2015
 Page No : 4

Start Time	TH-41 Southbound					School entrance Westbound					TH-41 Northbound					driveway Eastbound					Int. Total
	Left	Thru	Right	Peds	App. Total	Left	Thru	Right	Peds	App. Total	Left	Thru	Right	Peds	App. Total	Left	Thru	Right	Peds	App. Total	
Peak Hour Analysis From 12:00 to 21:30 - Peak 1 of 1																					
Peak Hour for Entire Intersection Begins at 16:00																					
16:00	47	142	0	0	189	34	1	70	0	105	0	189	20	0	209	0	0	0	0	0	503
16:15	29	136	0	0	165	20	0	61	1	82	0	204	14	0	218	0	0	0	0	0	465
16:30	16	135	0	0	151	12	0	22	0	34	0	217	11	0	228	0	0	0	0	0	413
16:45	10	169	0	0	179	7	0	18	0	25	0	228	10	0	238	0	0	0	0	0	442
Total Volume	102	582	0	0	684	73	1	171	1	246	0	838	55	0	893	0	0	0	0	0	1823
% App. Total	14.9	85.1	0	0		29.7	0.4	69.5	0.4		0	93.8	6.2	0		0	0	0	0		
PHF	.543	.861	.000	.000	.905	.537	.250	.611	.250	.586	.000	.919	.688	.000	.938	.000	.000	.000	.000	.000	.906

