

Albeck Gerken, Inc

Transportation Engineers

Traffic Data Collection

TH-47 / University Ave at 44th Ave NE

Ref.Pt.: 006.245

Data by: Albeck Gerken Inc

TURN MOVEMENT COUNT

File Name : TH-47 at 44th Ave NE 2008

Site Code : 01828131

Start Date : 7/10/2008

Page No : 1

Groups Printed- Unshifted

Start Time	TH-47 / University Ave Southbound				44th Ave NE Westbound				TH-47 / University Ave Northbound				44th Ave NE Eastbound				Int. Total
	Left	Thru	Right	Peds	Left	Thru	Right	Peds	Left	Thru	Right	Peds	Left	Thru	Right	Peds	
06:00	7	142	12	0	7	7	22	0	1	37	4	0	4	6	8	0	257
06:15	5	177	24	2	17	22	15	1	1	55	0	2	5	4	3	2	335
06:30	5	210	28	0	20	35	23	1	7	76	5	0	7	11	6	0	434
06:45	13	275	35	2	13	43	17	0	4	58	3	1	10	13	7	1	495
Total	30	804	99	4	57	107	77	2	13	226	12	3	26	34	24	3	1521
07:00	8	251	17	1	22	29	18	0	3	64	4	2	10	8	11	0	448
07:15	11	270	12	4	14	39	11	1	7	84	7	1	12	17	3	2	495
07:30	8	286	18	1	25	50	23	0	6	96	3	0	14	14	8	0	552
07:45	9	295	18	0	16	36	16	0	5	109	6	1	10	11	12	0	544
Total	36	1102	65	6	77	154	68	1	21	353	20	4	46	50	34	2	2039
08:00	9	194	7	0	13	27	23	1	4	87	2	1	12	14	7	0	401
08:15	11	204	13	0	16	27	22	0	5	81	3	0	10	12	6	0	410
08:30	13	138	9	0	10	28	17	0	3	88	6	1	11	12	6	0	342
08:45	19	157	10	0	15	15	14	0	3	78	9	1	7	10	5	0	343
Total	52	693	39	0	54	97	76	1	15	334	20	3	40	48	24	0	1496
*** BREAK ***																	
11:00	18	105	10	1	7	15	14	0	4	98	8	0	16	13	6	0	315
11:15	15	104	3	0	8	24	18	0	2	89	3	1	11	20	2	0	300
11:30	18	101	4	0	9	22	11	0	5	112	5	0	21	20	4	0	332
11:45	33	110	7	1	10	22	14	0	2	101	7	0	8	23	2	0	340
Total	84	420	24	2	34	83	57	0	13	400	23	1	56	76	14	0	1287
12:00	23	102	15	4	8	26	18	0	4	117	7	0	8	21	4	0	357
12:15	19	128	10	4	10	16	11	1	4	111	8	1	5	25	3	0	356
12:30	31	114	9	0	13	13	14	0	3	122	5	2	6	21	5	0	358
12:45	19	132	8	2	8	20	21	0	3	125	5	1	13	27	5	0	389
Total	92	476	42	10	39	75	64	1	14	475	25	4	32	94	17	0	1460
*** BREAK ***																	
15:00	19	120	11	0	8	19	21	0	7	142	19	0	21	17	3	0	407
15:15	33	108	8	0	8	19	21	0	6	179	16	1	15	30	7	0	451
15:30	20	152	11	0	10	27	22	0	8	226	11	1	13	31	8	0	540
15:45	25	112	9	0	13	21	18	0	7	235	17	0	8	46	4	0	515
Total	97	492	39	0	39	86	82	0	28	782	63	2	57	124	22	0	1913
16:00	34	120	12	0	12	31	21	0	3	252	17	1	7	47	9	0	566
16:15	21	145	10	0	11	24	22	0	7	255	19	0	18	33	4	0	569
16:30	23	113	14	3	12	31	15	0	10	337	19	1	17	38	6	0	639
16:45	39	141	11	0	5	30	24	0	7	311	18	0	15	42	8	0	651
Total	117	519	47	3	40	116	82	0	27	1155	73	2	57	160	27	0	2425
17:00	29	126	13	5	8	41	16	1	15	292	25	0	12	57	10	0	650
17:15	25	141	17	0	4	36	22	0	13	307	20	0	20	47	8	0	660
17:30	23	118	18	1	8	28	19	0	6	247	17	1	28	42	3	0	559
17:45	20	135	16	1	13	27	16	1	7	190	16	1	17	40	9	0	509
Total	97	520	64	7	33	132	73	2	41	1036	78	2	77	186	30	0	2378
Grand Total	605	5026	419	32	373	850	579	7	172	4761	314	21	391	772	192	5	14519
Apprch %	9.9	82.6	6.9	0.5	20.6	47	32	0.4	3.3	90.4	6	0.4	28.8	56.8	14.1	0.4	
Total %	4.2	34.6	2.9	0.2	2.6	5.9	4	0	1.2	32.8	2.2	0.1	2.7	5.3	1.3	0	

Albeck Gerken, Inc

Transportation Engineers

Traffic Data Collection

TH-47 / University Ave at 44th Ave NE

Ref.Pt.: 006.245

Data by: Albeck Gerken Inc

TURN MOVEMENT COUNT

File Name : TH-47 at 44th Ave NE 2008

Site Code : 01828131

Start Date : 7/10/2008

Page No : 2

Start Time	TH-47 / University Ave Southbound					44th Ave NE Westbound					TH-47 / University Ave Northbound					44th Ave NE Eastbound					Int. Total
	Left	Thru	Right	Peds	App. Total	Left	Thru	Right	Peds	App. Total	Left	Thru	Right	Peds	App. Total	Left	Thru	Right	Peds	App. Total	
Peak Hour Analysis From 06:00 to 08:45 - Peak 1 of 1																					
Peak Hour for Entire Intersection Begins at 07:00																					
07:00	8	251	17	1	277	22	29	18	0	69	3	64	4	2	73	10	8	11	0	29	448
07:15	11	270	12	4	297	14	39	11	1	65	7	84	7	1	99	12	17	3	2	34	495
07:30	8	286	18	1	313	25	50	23	0	98	6	96	3	0	105	14	14	8	0	36	552
07:45	9	295	18	0	322	16	36	16	0	68	5	109	6	1	121	10	11	12	0	33	544
Total Volume	36	1102	65	6	1209	77	154	68	1	300	21	353	20	4	398	46	50	34	2	132	2039
% App. Total	3	91.1	5.4	0.5		25.7	51.3	22.7	0.3		5.3	88.7	5	1		34.8	37.9	25.8	1.5		
PHF	.818	.934	.903	.375	.939	.770	.770	.739	.250	.765	.750	.810	.714	.500	.822	.821	.735	.708	.250	.917	.923

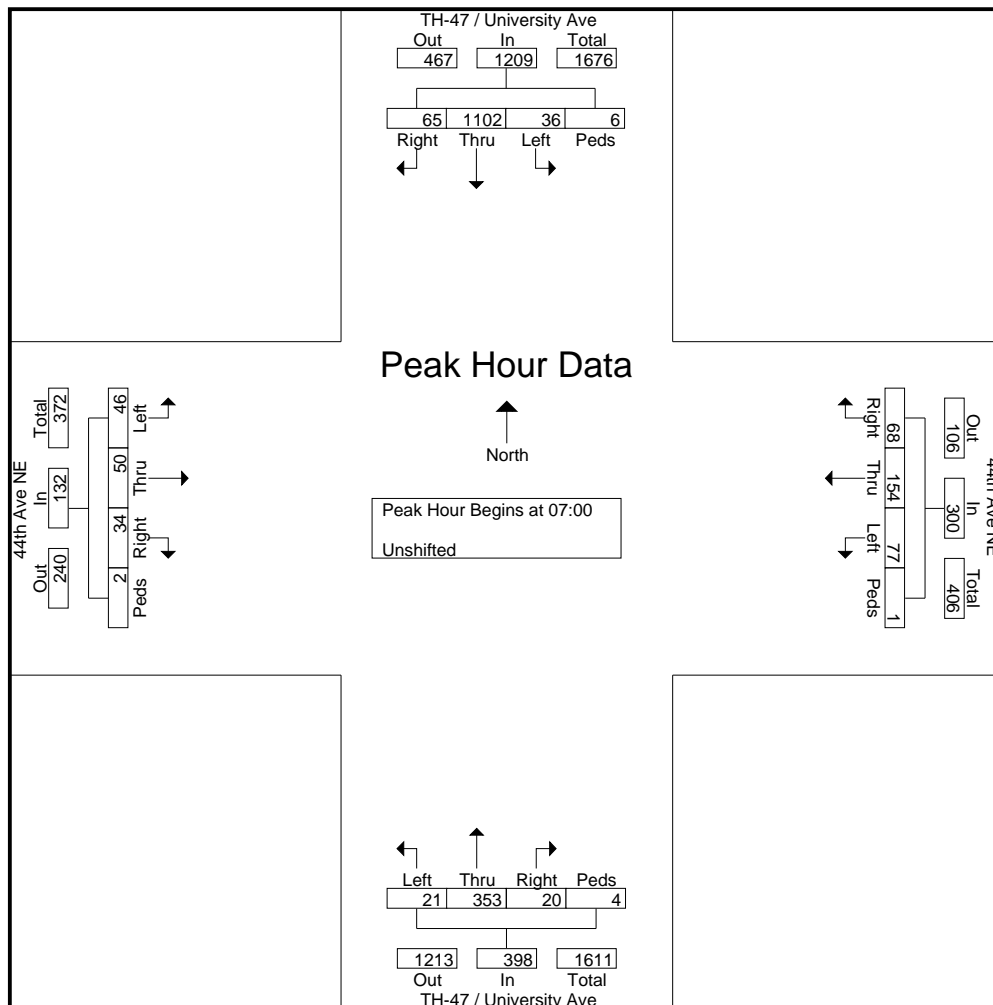

Albeck Gerken, Inc

Transportation Engineers

Traffic Data Collection

TH-47 / University Ave at 44th Ave NE

Ref.Pt.: 006.245

Data by: Albeck Gerken Inc

TURN MOVEMENT COUNT

File Name : TH-47 at 44th Ave NE 2008

Site Code : 01828131

Start Date : 7/10/2008

Page No : 3

Start Time	TH-47 / University Ave Southbound					44th Ave NE Westbound					TH-47 / University Ave Northbound					44th Ave NE Eastbound					Int. Total
	Left	Thru	Right	Peds	App. Total	Left	Thru	Right	Peds	App. Total	Left	Thru	Right	Peds	App. Total	Left	Thru	Right	Peds	App. Total	
Peak Hour Analysis From 15:00 to 17:45 - Peak 1 of 1																					
Peak Hour for Entire Intersection Begins at 16:30																					
16:30	23	113	14	3	153	12	31	15	0	58	10	337	19	1	367	17	38	6	0	61	639
16:45	39	141	11	0	191	5	30	24	0	59	7	311	18	0	336	15	42	8	0	65	651
17:00	29	126	13	5	173	8	41	16	1	66	15	292	25	0	332	12	57	10	0	79	650
17:15	25	141	17	0	183	4	36	22	0	62	13	307	20	0	340	20	47	8	0	75	660
Total Volume	116	521	55	8	700	29	138	77	1	245	45	1247	82	1	1375	64	184	32	0	280	2600
% App. Total	16.6	74.4	7.9	1.1		11.8	56.3	31.4	0.4		3.3	90.7	6	0.1		22.9	65.7	11.4	0		
PHF	.744	.924	.809	.400	.916	.604	.841	.802	.250	.928	.750	.925	.820	.250	.937	.800	.807	.800	.000	.886	.985

