

Albeck Gerken, Inc

Transportation Engineers

Traffic Data Collection

TH-47 / University Ave at 53rd Ave NE

Ref.Pt.: 007.373

Data by: Albeck Gerkin Inc

TURN MOVEMENT COUNT

File Name : TH-47 at 53rd Ave NE 2008

Site Code : 01828151

Start Date : 7/10/2008

Page No : 1

Groups Printed- Unshifted

Start Time	TH-47 / University Ave Southbound				53rd Ave NE Westbound				TH-47 / University Ave Northbound				53rd Ave NE Eastbound				Int. Total
	Left	Thru	Right	Peds	Left	Thru	Right	Peds	Left	Thru	Right	Peds	Left	Thru	Right	Peds	
06:00	8	142	21	1	6	4	22	0	0	73	1	0	14	2	2	0	296
06:15	8	185	19	0	9	4	18	2	1	91	3	4	14	1	3	0	362
06:30	15	242	30	4	20	4	23	0	3	120	6	0	19	4	3	0	493
06:45	17	270	39	0	22	9	32	2	2	117	3	4	11	1	3	0	532
Total	48	839	109	5	57	21	95	4	6	401	13	8	58	8	11	0	1683
07:00	14	225	25	3	25	8	22	2	0	113	4	1	17	5	1	0	465
07:15	13	276	20	0	19	9	26	0	2	122	7	1	24	0	2	5	526
07:30	20	265	19	1	40	9	30	1	1	169	10	1	10	5	3	0	584
07:45	19	251	30	2	34	9	35	0	2	134	7	6	12	8	3	0	552
Total	66	1017	94	6	118	35	113	3	5	538	28	9	63	18	9	5	2127
08:00	26	195	13	1	15	10	32	3	2	119	8	3	12	5	4	0	448
08:15	16	182	19	6	25	6	23	5	1	130	11	1	19	10	3	0	457
08:30	18	148	15	0	8	3	34	0	1	121	9	0	20	9	6	0	392
08:45	29	167	11	0	11	10	32	2	3	101	9	5	13	8	4	0	405
Total	89	692	58	7	59	29	121	10	7	471	37	9	64	32	17	0	1702
*** BREAK ***																	
11:00	23	121	24	5	4	15	30	1	1	110	13	2	13	12	0	2	376
11:15	32	133	22	1	9	10	33	2	1	120	12	3	13	3	0	0	394
11:30	29	130	15	0	7	5	39	0	1	142	12	0	19	15	2	0	416
11:45	30	146	18	0	9	9	39	0	4	111	7	1	12	15	2	0	403
Total	114	530	79	6	29	39	141	3	7	483	44	6	57	45	4	2	1589
12:00	32	140	19	1	7	10	34	0	3	142	11	2	17	18	2	0	438
12:15	30	161	22	4	11	19	59	1	1	126	5	1	13	14	2	1	470
12:30	35	158	19	1	9	18	38	0	3	119	11	0	13	4	1	0	429
12:45	46	167	16	1	5	12	39	0	3	164	7	0	12	9	0	0	481
Total	143	626	76	7	32	59	170	1	10	551	34	3	55	45	5	1	1818
*** BREAK ***																	
15:00	34	158	25	2	9	8	23	0	1	188	17	3	28	12	2	0	510
15:15	45	160	40	2	5	10	29	2	2	204	18	3	13	13	3	1	550
15:30	25	181	22	0	12	19	35	0	1	260	14	5	37	16	0	0	627
15:45	44	166	32	0	6	12	18	0	5	264	15	2	19	10	4	0	597
Total	148	665	119	4	32	49	105	2	9	916	64	13	97	51	9	1	2284
16:00	43	174	23	2	9	17	36	1	1	249	20	0	20	8	1	0	604
16:15	39	179	33	0	17	16	39	2	1	262	24	1	20	9	3	0	645
16:30	48	165	25	0	16	13	35	1	2	325	26	0	30	17	1	0	704
16:45	43	191	29	0	14	9	38	1	8	296	31	0	13	8	2	0	683
Total	173	709	110	2	56	55	148	5	12	1132	101	1	83	42	7	0	2636
17:00	44	158	26	6	14	9	43	0	4	283	15	2	21	14	5	0	644
17:15	43	163	34	2	22	13	29	0	2	309	34	0	12	19	1	0	683
17:30	57	162	15	4	18	9	52	4	4	258	22	1	13	11	1	0	631
17:45	37	193	21	5	15	31	44	1	0	187	20	5	7	13	2	3	584
Total	181	676	96	17	69	62	168	5	10	1037	91	8	53	57	9	3	2542
Grand Total	962	5754	741	54	452	349	1061	33	66	5529	412	57	530	298	71	12	16381
Apprch %	12.8	76.6	9.9	0.7	23.9	18.4	56	1.7	1.1	91.2	6.8	0.9	58.2	32.7	7.8	1.3	
Total %	5.9	35.1	4.5	0.3	2.8	2.1	6.5	0.2	0.4	33.8	2.5	0.3	3.2	1.8	0.4	0.1	

Albeck Gerken, Inc

Transportation Engineers

Traffic Data Collection

TH-47 / University Ave at 53rd Ave NE

Ref.Pt.: 007.373

Data by: Albeck Gerkin Inc

TURN MOVEMENT COUNT

File Name : TH-47 at 53rd Ave NE 2008

Site Code : 01828151

Start Date : 7/10/2008

Page No : 2

Start Time	TH-47 / University Ave Southbound					53rd Ave NE Westbound					TH-47 / University Ave Northbound					53rd Ave NE Eastbound					Int. Total
	Left	Thru	Right	Peds	App. Total	Left	Thru	Right	Peds	App. Total	Left	Thru	Right	Peds	App. Total	Left	Thru	Right	Peds	App. Total	
Peak Hour Analysis From 06:00 to 08:45 - Peak 1 of 1																					
Peak Hour for Entire Intersection Begins at 07:00																					
07:00	14	225	25	3	267	25	8	22	2	57	0	113	4	1	118	17	5	1	0	23	465
07:15	13	276	20	0	309	19	9	26	0	54	2	122	7	1	132	24	0	2	5	31	526
07:30	20	265	19	1	305	40	9	30	1	80	1	169	10	1	181	10	5	3	0	18	584
07:45	19	251	30	2	302	34	9	35	0	78	2	134	7	6	149	12	8	3	0	23	552
Total Volume	66	1017	94	6	1183	118	35	113	3	269	5	538	28	9	580	63	18	9	5	95	2127
% App. Total	5.6	86	7.9	0.5		43.9	13	42	1.1		0.9	92.8	4.8	1.6		66.3	18.9	9.5	5.3		
PHF	.825	.921	.783	.500	.957	.738	.972	.807	.375	.841	.625	.796	.700	.375	.801	.656	.563	.750	.250	.766	.911

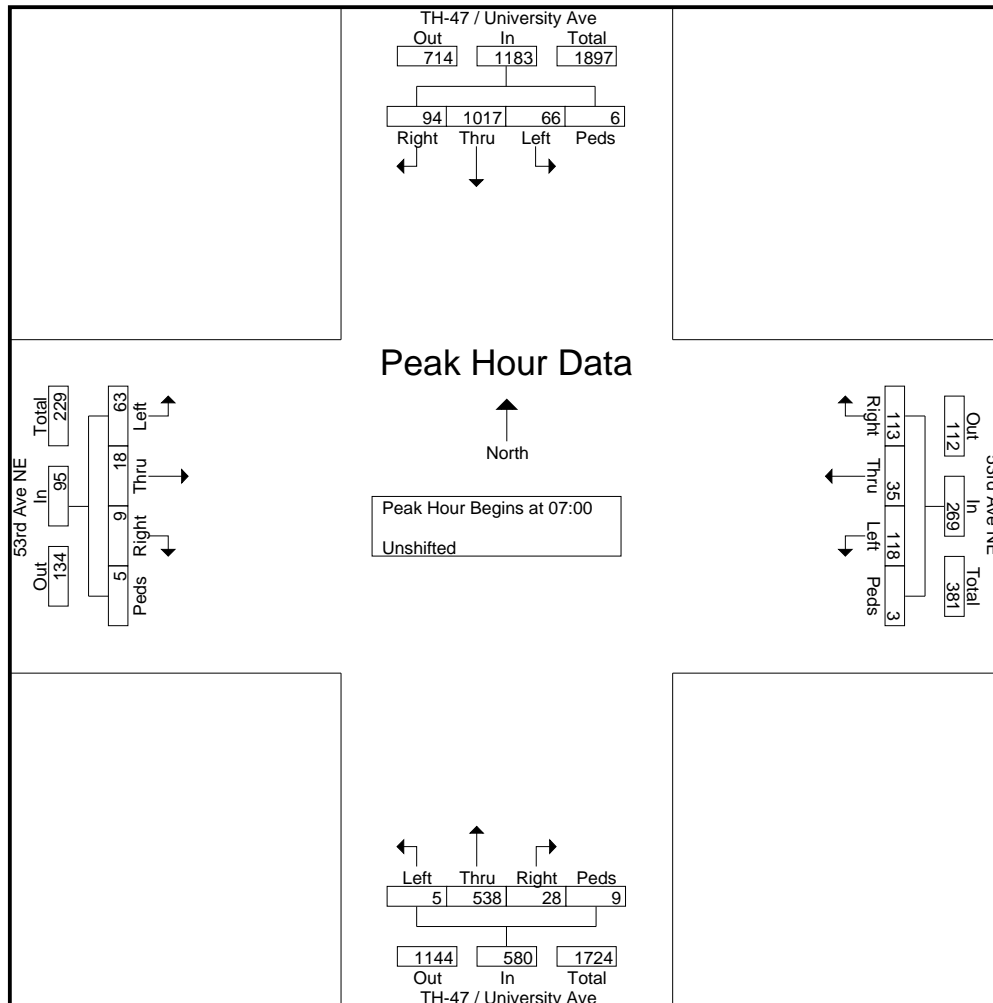

Albeck Gerken, Inc

Transportation Engineers

Traffic Data Collection

TH-47 / University Ave at 53rd Ave NE

Ref.Pt.: 007.373

Data by: Albeck Gerkin Inc

TURN MOVEMENT COUNT

File Name : TH-47 at 53rd Ave NE 2008

Site Code : 01828151

Start Date : 7/10/2008

Page No : 3

Start Time	TH-47 / University Ave Southbound					53rd Ave NE Westbound					TH-47 / University Ave Northbound					53rd Ave NE Eastbound					Int. Total
	Left	Thru	Right	Peds	App. Total	Left	Thru	Right	Peds	App. Total	Left	Thru	Right	Peds	App. Total	Left	Thru	Right	Peds	App. Total	
Peak Hour Analysis From 15:00 to 17:45 - Peak 1 of 1																					
Peak Hour for Entire Intersection Begins at 16:30																					
16:30	48	165	25	0	238	16	13	35	1	65	2	325	26	0	353	30	17	1	0	48	704
16:45	43	191	29	0	263	14	9	38	1	62	8	296	31	0	335	13	8	2	0	23	683
17:00	44	158	26	6	234	14	9	43	0	66	4	283	15	2	304	21	14	5	0	40	644
17:15	43	163	34	2	242	22	13	29	0	64	2	309	34	0	345	12	19	1	0	32	683
Total Volume	178	677	114	8	977	66	44	145	2	257	16	1213	106	2	1337	76	58	9	0	143	2714
% App. Total	18.2	69.3	11.7	0.8		25.7	17.1	56.4	0.8		1.2	90.7	7.9	0.1		53.1	40.6	6.3	0		
PHF	.927	.886	.838	.333	.929	.750	.846	.843	.500	.973	.500	.933	.779	.250	.947	.633	.763	.450	.000	.745	.964

