



MINNESOTA DEPT OF TRANSPORTATION
TRAFFIC DATA COLLECTION - METRO

MN-51 / SNELLING AVE. AT HOYT AVE. File Name : TH-51 SNELLING AVE AT HOYT AVE 2007
 REF.PT.: 006.105 Site Code : 00198732
 DATA COLLECTED BY TDI Start Date : 5/22/2007
 TURN MOVEMENT COUNT Page No : 1

Groups Printed- Unshifted

Start Time	MN-51 / Snelling Ave. Southbound				Hoyt Ave Westbound				MN-51 / Snelling Ave. Northbound				Hoyt Ave Eastbound				Int. Total
	Left	Thru	Right	Peds	Left	Thru	Right	Peds	Left	Thru	Right	Peds	Left	Thru	Right	Peds	
06:00	0	128	0	0	5	1	7	0	1	74	0	1	0	0	0	0	217
06:15	1	182	0	0	4	0	5	0	1	94	1	3	0	0	0	0	291
06:30	1	252	0	1	12	0	10	0	0	139	3	1	0	0	1	0	420
06:45	0	298	0	2	14	0	11	1	1	152	2	2	0	1	0	0	484
Total	2	860	0	3	35	1	33	1	3	459	6	7	0	1	1	0	1412
07:00	3	292	1	2	11	1	7	1	0	183	1	2	0	0	1	1	506
07:15	6	375	0	3	20	0	15	0	1	215	4	1	1	0	1	0	642
07:30	5	337	1	1	16	0	18	1	0	277	1	4	0	0	0	0	661
07:45	0	431	1	0	9	0	14	2	0	279	7	7	1	0	1	4	756
Total	14	1435	3	6	56	1	54	4	1	954	13	14	2	0	3	5	2565
08:00	2	391	0	2	14	0	11	0	6	231	7	3	0	0	0	1	668
08:15	3	346	3	0	24	2	17	1	0	241	10	4	0	0	2	0	653
08:30	2	348	0	0	8	0	17	0	2	270	2	3	1	0	0	1	654
08:45	5	320	0	5	7	0	8	0	0	233	5	2	0	0	0	0	585
Total	12	1405	3	7	53	2	53	1	8	975	24	12	1	0	2	2	2560
*** BREAK ***																	
11:00	6	238	3	0	3	0	2	0	1	278	6	0	2	1	2	0	542
11:15	2	236	2	0	6	0	3	0	1	268	4	1	4	1	2	0	530
11:30	7	238	0	0	4	1	5	0	1	332	3	0	2	0	1	0	594
11:45	6	292	2	0	4	0	8	0	1	324	1	2	0	0	2	0	642
Total	21	1004	7	0	17	1	18	0	4	1202	14	3	8	2	7	0	2308
12:00	8	273	0	0	2	0	3	0	1	324	3	0	3	0	0	0	617
12:15	5	274	2	2	4	0	5	0	2	339	3	0	0	3	1	0	640
12:30	3	318	2	0	2	1	6	0	2	306	2	0	0	0	0	0	642
12:45	3	337	1	0	4	1	5	0	0	307	8	2	1	2	0	0	671
Total	19	1202	5	2	12	2	19	0	5	1276	16	2	4	5	1	0	2570
*** BREAK ***																	
15:00	3	279	0	1	7	0	6	0	0	356	11	1	0	0	2	0	666
15:15	4	308	1	0	6	0	6	0	2	389	11	0	0	1	1	0	729
15:30	2	267	0	2	6	0	4	0	1	456	6	1	0	1	2	0	748
15:45	3	267	0	0	7	0	2	0	2	448	15	8	0	0	0	4	756
Total	12	1121	1	3	26	0	18	0	5	1649	43	10	0	2	5	4	2899
16:00	7	281	0	3	9	1	8	1	2	451	11	2	0	1	2	1	780
16:15	4	272	0	0	7	0	2	5	1	458	26	2	0	0	0	0	777
16:30	3	275	2	2	3	0	1	2	5	498	17	2	0	0	3	1	814
16:45	3	318	4	0	7	3	1	0	2	481	30	1	0	2	4	0	856
Total	17	1146	6	5	26	4	12	8	10	1888	84	7	0	3	9	2	3227
17:00	4	277	2	0	9	0	4	1	7	490	23	4	0	0	6	3	830
17:15	5	351	3	2	6	0	6	2	3	435	16	3	1	1	5	0	839
17:30	7	324	1	0	3	0	2	0	2	395	20	1	1	0	3	1	760
17:45	15	308	2	0	3	0	1	1	2	365	14	3	1	0	1	4	720
Total	31	1260	8	2	21	0	13	4	14	1685	73	11	3	1	15	8	3149



MINNESOTA DEPT OF TRANSPORTATION
 TRAFFIC DATA COLLECTION - METRO

MN-51 / SNELLING AVE. AT HOYT AVE. File Name : TH-51 SNELLING AVE AT HOYT AVE 2007
 REF.PT.: 006.105 Site Code : 00198732
 DATA COLLECTED BY TDI Start Date : 5/22/2007
 TURN MOVEMENT COUNT Page No : 2

Groups Printed- Unshifted

	MN-51 / Snelling Ave. Southbound				Hoyt Ave Westbound				MN-51 / Snelling Ave. Northbound				Hoyt Ave Eastbound				Int. Total
	Left	Thru	Right	Peds	Left	Thru	Right	Peds	Left	Thru	Right	Peds	Left	Thru	Right	Peds	
Grand Total	128	9433	33	28	246	11	220	18	50	10088	273	66	18	14	43	21	20690
Apprch %	1.3	98	0.3	0.3	49.7	2.2	44.4	3.6	0.5	96.3	2.6	0.6	18.8	14.6	44.8	21.9	
Total %	0.6	45.6	0.2	0.1	1.2	0.1	1.1	0.1	0.2	48.8	1.3	0.3	0.1	0.1	0.2	0.1	



MINNESOTA DEPT OF TRANSPORTATION

TRAFFIC DATA COLLECTION - METRO

MN-51 / SNELLING AVE. AT HOYT AVE. File Name : TH-51 SNELLING AVE AT HOYT AVE 2007
 REF.PT.: 006.105 Site Code : 00198732
 DATA COLLECTED BY TDI Start Date : 5/22/2007
 TURN MOVEMENT COUNT Page No : 3

Start Time	MN-51 / Snelling Ave. Southbound					Hoyt Ave Westbound					MN-51 / Snelling Ave. Northbound					Hoyt Ave Eastbound					Int. Total
	Left	Thru	Right	Peds	App. Total	Left	Thru	Right	Peds	App. Total	Left	Thru	Right	Peds	App. Total	Left	Thru	Right	Peds	App. Total	
Peak Hour Analysis From 06:00 to 08:45 - Peak 1 of 1																					
Peak Hour for Entire Intersection Begins at 07:30																					
07:30	5	337	1	1	344	16	0	18	1	35	0	277	1	4	282	0	0	0	0	0	661
07:45	0	431	1	0	432	9	0	14	2	25	0	279	7	7	293	1	0	1	4	6	756
08:00	2	391	0	2	395	14	0	11	0	25	6	231	7	3	247	0	0	0	1	1	668
08:15	3	346	3	0	352	24	2	17	1	44	0	241	10	4	255	0	0	2	0	2	653
Total Volume	10	1505	5	3	1523	63	2	60	4	129	6	1028	25	18	1077	1	0	3	5	9	2738
% App. Total	0.7	98.8	0.3	0.2		48.8	1.6	46.5	3.1		0.6	95.5	2.3	1.7		11.1	0	33.3	55.6		
PHF	.500	.873	.417	.375	.881	.656	.250	.833	.500	.733	.250	.921	.625	.643	.919	.250	.000	.375	.313	.375	.905

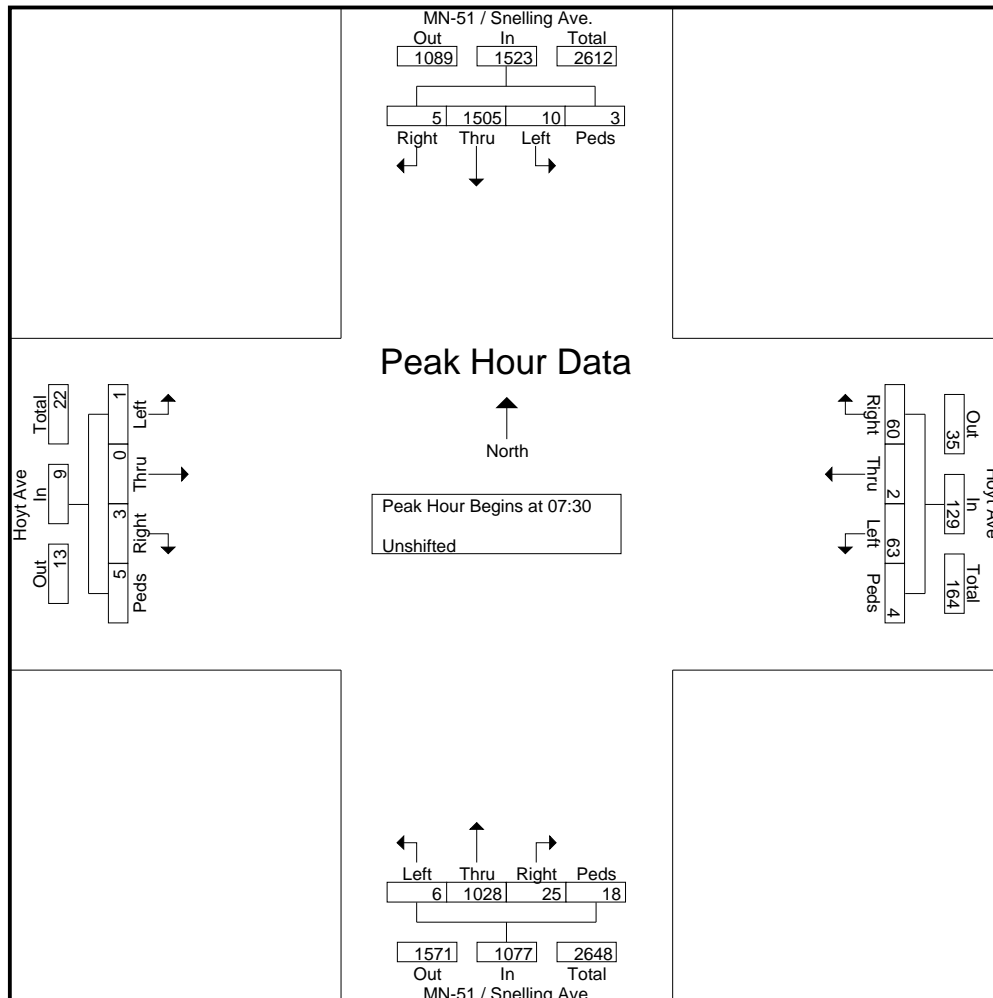



MINNESOTA DEPT OF TRANSPORTATION

TRAFFIC DATA COLLECTION - METRO

MN-51 / SNELLING AVE. AT HOYT AVE. File Name : TH-51 SNELLING AVE AT HOYT AVE 2007
 REF.PT.: 006.105 Site Code : 00198732
 DATA COLLECTED BY TDI Start Date : 5/22/2007
 TURN MOVEMENT COUNT Page No : 4

Start Time	MN-51 / Snelling Ave. Southbound					Hoyt Ave Westbound					MN-51 / Snelling Ave. Northbound					Hoyt Ave Eastbound					Int. Total
	Left	Thru	Right	Peds	App. Total	Left	Thru	Right	Peds	App. Total	Left	Thru	Right	Peds	App. Total	Left	Thru	Right	Peds	App. Total	
Peak Hour Analysis From 15:00 to 17:45 - Peak 1 of 1																					
Peak Hour for Entire Intersection Begins at 16:30																					
16:30	3	275	2	2	282	3	0	1	2	6	5	498	17	2	522	0	0	3	1	4	814
16:45	3	318	4	0	325	7	3	1	0	11	2	481	30	1	514	0	2	4	0	6	856
17:00	4	277	2	0	283	9	0	4	1	14	7	490	23	4	524	0	0	6	3	9	830
17:15	5	351	3	2	361	6	0	6	2	14	3	435	16	3	457	1	1	5	0	7	839
Total Volume	15	1221	11	4	1251	25	3	12	5	45	17	1904	86	10	2017	1	3	18	4	26	3339
% App. Total	1.2	97.6	0.9	0.3		55.6	6.7	26.7	11.1		0.8	94.4	4.3	0.5		3.8	11.5	69.2	15.4		
PHF	.750	.870	.688	.500	.866	.694	.250	.500	.625	.804	.607	.956	.717	.625	.962	.250	.375	.750	.333	.722	.975

