



# MINNESOTA DEPT OF TRANSPORTATION

## TRAFFIC DATA COLLECTION - METRO

MN-51 / SNELLING AVE AT Co.Rd.C  
 REF.PT.: 008.854  
 DATA COLLECTED BY TDI  
 TURN MOVEMENT COUNT

File Name : TH-51 SNELLING AVE AT CO RD C 2007  
 Site Code : 01987312  
 Start Date : 5/24/2007  
 Page No : 1

**Groups Printed- Unshifted**

Start Time	MN-51 / SNELLING AVE. Southbound				County Rd C Westbound				MN-51 / SNELLING AVE. Northbound				County Rd C Eastbound				Int. Total
	Left	Thru	Right	Peds	Left	Thru	Right	Peds	Left	Thru	Right	Peds	Left	Thru	Right	Peds	
06:00	4	109	12	0	12	12	0	0	41	45	12	0	2	13	24	0	286
06:15	4	190	13	1	14	19	2	1	39	53	10	1	3	10	26	0	386
06:30	3	273	12	0	22	38	4	0	57	69	18	0	4	18	39	0	557
06:45	12	293	23	1	21	53	2	0	53	101	34	0	10	22	42	0	667
<b>Total</b>	<b>23</b>	<b>865</b>	<b>60</b>	<b>2</b>	<b>69</b>	<b>122</b>	<b>8</b>	<b>1</b>	<b>190</b>	<b>268</b>	<b>74</b>	<b>1</b>	<b>19</b>	<b>63</b>	<b>131</b>	<b>0</b>	<b>1896</b>
07:00	5	340	27	0	20	46	2	0	50	105	26	1	5	15	44	1	687
07:15	2	398	31	0	25	80	4	0	45	159	18	0	6	32	36	1	837
07:30	11	432	28	0	29	109	1	0	48	166	20	0	12	29	40	1	926
07:45	11	427	40	0	36	114	5	0	43	205	35	0	13	38	48	0	1015
<b>Total</b>	<b>29</b>	<b>1597</b>	<b>126</b>	<b>0</b>	<b>110</b>	<b>349</b>	<b>12</b>	<b>0</b>	<b>186</b>	<b>635</b>	<b>99</b>	<b>1</b>	<b>36</b>	<b>114</b>	<b>168</b>	<b>3</b>	<b>3465</b>
08:00	13	400	50	0	38	121	11	0	60	165	36	0	4	36	35	1	970
08:15	9	371	46	0	36	90	10	0	54	131	32	0	6	32	42	0	859
08:30	10	261	42	0	29	108	12	0	52	112	34	0	8	38	48	0	754
08:45	9	278	26	0	26	79	4	0	71	167	33	0	15	34	37	0	779
<b>Total</b>	<b>41</b>	<b>1310</b>	<b>164</b>	<b>0</b>	<b>129</b>	<b>398</b>	<b>37</b>	<b>0</b>	<b>237</b>	<b>575</b>	<b>135</b>	<b>0</b>	<b>33</b>	<b>140</b>	<b>162</b>	<b>1</b>	<b>3362</b>
*** BREAK ***																	
11:00	11	178	25	1	32	64	8	1	62	134	32	1	16	45	68	1	679
11:15	15	191	29	1	47	56	10	0	89	123	34	0	16	64	76	0	751
11:30	14	183	24	2	35	74	6	0	77	153	58	2	15	67	70	1	781
11:45	11	222	32	1	47	66	9	0	94	165	46	0	22	77	82	1	875
<b>Total</b>	<b>51</b>	<b>774</b>	<b>110</b>	<b>5</b>	<b>161</b>	<b>260</b>	<b>33</b>	<b>1</b>	<b>322</b>	<b>575</b>	<b>170</b>	<b>3</b>	<b>69</b>	<b>253</b>	<b>296</b>	<b>3</b>	<b>3086</b>
12:00	24	183	19	0	62	78	7	0	90	139	39	0	21	85	88	0	835
12:15	14	177	25	0	59	81	9	0	92	170	54	0	17	68	70	0	836
12:30	16	193	18	0	44	82	12	0	91	172	39	0	32	67	92	0	858
12:45	7	202	20	2	68	78	4	0	79	184	51	0	23	82	84	1	885
<b>Total</b>	<b>61</b>	<b>755</b>	<b>82</b>	<b>2</b>	<b>233</b>	<b>319</b>	<b>32</b>	<b>0</b>	<b>352</b>	<b>665</b>	<b>183</b>	<b>0</b>	<b>93</b>	<b>302</b>	<b>334</b>	<b>1</b>	<b>3414</b>
*** BREAK ***																	
15:00	6	183	22	0	46	57	8	0	65	250	27	1	30	83	79	0	857
15:15	11	231	17	0	31	62	10	0	72	356	31	0	37	76	69	1	1004
15:30	21	231	19	0	25	68	16	0	72	336	36	0	49	101	83	0	1057
15:45	11	244	9	0	36	67	15	0	79	395	51	0	76	115	86	0	1184
<b>Total</b>	<b>49</b>	<b>889</b>	<b>67</b>	<b>0</b>	<b>138</b>	<b>254</b>	<b>49</b>	<b>0</b>	<b>288</b>	<b>1337</b>	<b>145</b>	<b>1</b>	<b>192</b>	<b>375</b>	<b>317</b>	<b>1</b>	<b>4102</b>
16:00	21	232	15	1	57	58	13	0	75	406	47	0	73	120	76	3	1197
16:15	14	254	17	0	62	91	7	1	70	386	49	0	68	110	87	0	1216
16:30	16	290	7	0	54	72	9	1	82	429	39	1	74	148	84	0	1306
16:45	12	252	11	0	43	99	22	1	84	436	30	2	60	153	89	1	1295
<b>Total</b>	<b>63</b>	<b>1028</b>	<b>50</b>	<b>1</b>	<b>216</b>	<b>320</b>	<b>51</b>	<b>3</b>	<b>311</b>	<b>1657</b>	<b>165</b>	<b>3</b>	<b>275</b>	<b>531</b>	<b>336</b>	<b>4</b>	<b>5014</b>
17:00	14	273	10	0	46	70	22	0	67	438	50	0	76	169	120	1	1356
17:15	9	300	6	0	51	69	15	0	62	408	48	0	82	189	101	0	1340
17:30	32	308	13	0	49	72	11	0	72	398	39	0	74	135	89	0	1292
17:45	12	214	11	1	44	62	11	0	69	392	48	0	59	176	71	0	1170
<b>Total</b>	<b>67</b>	<b>1095</b>	<b>40</b>	<b>1</b>	<b>190</b>	<b>273</b>	<b>59</b>	<b>0</b>	<b>270</b>	<b>1636</b>	<b>185</b>	<b>0</b>	<b>291</b>	<b>669</b>	<b>381</b>	<b>1</b>	<b>5158</b>



**MINNESOTA DEPT OF TRANSPORTATION**  
 TRAFFIC DATA COLLECTION - METRO

MN-51 / SNELLING AVE AT Co.Rd.C  
 REF.PT.: 008.854  
 DATA COLLECTED BY TDI  
 TURN MOVEMENT COUNT

File Name : TH-51 SNELLING AVE AT CO RD C 2007  
 Site Code : 01987312  
 Start Date : 5/24/2007  
 Page No : 2

**Groups Printed- Unshifted**

	MN-51 / SNELLING AVE. Southbound				County Rd C Westbound				MN-51 / SNELLING AVE. Northbound				County Rd C Eastbound				Int. Total
	Left	Thru	Right	Peds	Left	Thru	Right	Peds	Left	Thru	Right	Peds	Left	Thru	Right	Peds	
Grand Total	384	8313	699	11	1246	2295	281	5	2156	7348	1156	9	1008	2447	2125	14	29497
Apprch %	4.1	88.4	7.4	0.1	32.6	60	7.3	0.1	20.2	68.9	10.8	0.1	18	43.7	38	0.3	
Total %	1.3	28.2	2.4	0	4.2	7.8	1	0	7.3	24.9	3.9	0	3.4	8.3	7.2	0	



# MINNESOTA DEPT OF TRANSPORTATION

## TRAFFIC DATA COLLECTION - METRO

MN-51 / SNELLING AVE AT Co.Rd.C  
 REF.PT.: 008.854  
 DATA COLLECTED BY TDI  
 TURN MOVEMENT COUNT

File Name : TH-51 SNELLING AVE AT CO RD C 2007  
 Site Code : 01987312  
 Start Date : 5/24/2007  
 Page No : 3

Start Time	MN-51 / SNELLING AVE. Southbound					County Rd C Westbound					MN-51 / SNELLING AVE. Northbound					County Rd C Eastbound					Int. Total
	Left	Thru	Right	Peds	App. Total	Left	Thru	Right	Peds	App. Total	Left	Thru	Right	Peds	App. Total	Left	Thru	Right	Peds	App. Total	
Peak Hour Analysis From 06:00 to 08:45 - Peak 1 of 1																					
Peak Hour for Entire Intersection Begins at 07:30																					
07:30	11	432	28	0	471	29	109	1	0	139	48	166	20	0	234	12	29	40	1	82	926
07:45	11	427	40	0	478	36	114	5	0	155	43	205	35	0	283	13	38	48	0	99	1015
08:00	13	400	50	0	463	38	121	11	0	170	60	165	36	0	261	4	36	35	1	76	970
08:15	9	371	46	0	426	36	90	10	0	136	54	131	32	0	217	6	32	42	0	80	859
Total Volume	44	1630	164	0	1838	139	434	27	0	600	205	667	123	0	995	35	135	165	2	337	3770
% App. Total	2.4	88.7	8.9	0		23.2	72.3	4.5	0		20.6	67	12.4	0		10.4	40.1	49	0.6		
PHF	.846	.943	.820	.000	.961	.914	.897	.614	.000	.882	.854	.813	.854	.000	.879	.673	.888	.859	.500	.851	.929

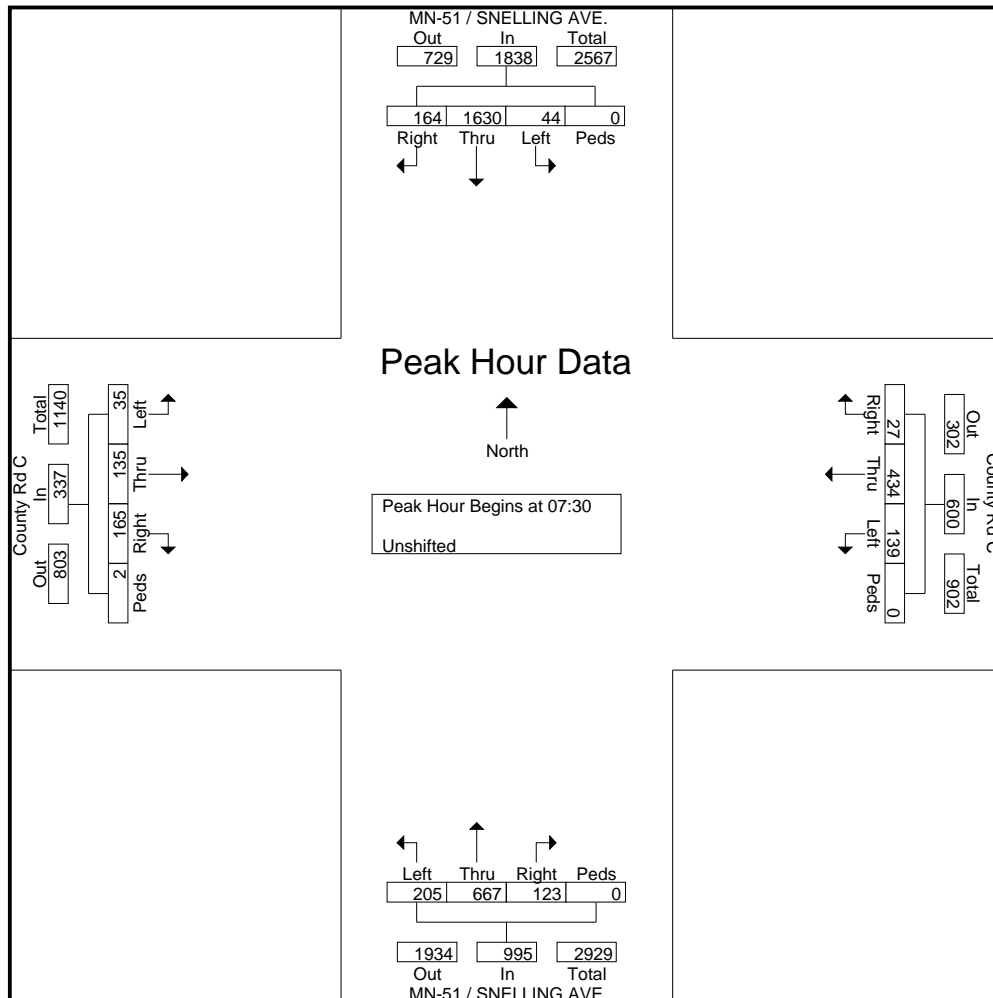



# MINNESOTA DEPT OF TRANSPORTATION

## TRAFFIC DATA COLLECTION - METRO

MN-51 / SNELLING AVE AT Co.Rd.C  
 REF.PT.: 008.854  
 DATA COLLECTED BY TDI  
 TURN MOVEMENT COUNT

File Name : TH-51 SNELLING AVE AT CO RD C 2007  
 Site Code : 01987312  
 Start Date : 5/24/2007  
 Page No : 4

Start Time	MN-51 / SNELLING AVE. Southbound					County Rd C Westbound					MN-51 / SNELLING AVE. Northbound					County Rd C Eastbound					Int. Total
	Left	Thru	Right	Peds	App. Total	Left	Thru	Right	Peds	App. Total	Left	Thru	Right	Peds	App. Total	Left	Thru	Right	Peds	App. Total	
Peak Hour Analysis From 15:00 to 17:45 - Peak 1 of 1																					
Peak Hour for Entire Intersection Begins at 16:30																					
16:30	16	290	7	0	313	54	72	9	1	136	82	429	39	1	551	74	148	84	0	306	1306
16:45	12	252	11	0	275	43	99	22	1	165	84	436	30	2	552	60	153	89	1	303	1295
17:00	14	273	10	0	297	46	70	22	0	138	67	438	50	0	555	76	169	120	1	366	1356
17:15	9	300	6	0	315	51	69	15	0	135	62	408	48	0	518	82	189	101	0	372	1340
Total Volume	51	1115	34	0	1200	194	310	68	2	574	295	1711	167	3	2176	292	659	394	2	1347	5297
% App. Total	4.2	92.9	2.8	0		33.8	54	11.8	0.3		13.6	78.6	7.7	0.1		21.7	48.9	29.3	0.1		
PHF	.797	.929	.773	.000	.952	.898	.783	.773	.500	.870	.878	.977	.835	.375	.980	.890	.872	.821	.500	.905	.977

