

Albeck Gerken, Inc

Transportation Engineers

Traffic Data Collection

TH-52 at 80th St E., east ramp
 Inver Grove Heights, MN
 Ref.Pt.: 122.516
 TURN MOVEMENT COUNT

File Name : TH-52 at 80th St E east ramp 2012
 Site Code : 40
 Start Date : 1/13/2012
 Page No : 1

Groups Printed- Cars - Heavy Vehicles

Start Time	loop from / ramp to TH-52 NB Southbound				80th St E Westbound				Broderick Blvd Northbound				80th St E Eastbound				Int. Total
	Left	Thru	Right	Peds	Left	Thru	Right	Peds	Left	Thru	Right	Peds	Left	Thru	Right	Peds	
06:00	1	0	0	0	3	30	43	0	1	3	0	0	22	17	2	0	122
06:15	3	0	0	1	1	26	59	0	1	5	0	0	31	17	3	0	147
06:30	3	1	0	2	1	39	71	0	4	11	1	0	44	38	5	0	220
06:45	3	0	1	0	1	39	73	0	3	17	3	0	57	74	4	0	275
Total	10	1	1	3	6	134	246	0	9	36	4	0	154	146	14	0	764
07:00	7	2	2	0	1	55	67	0	6	16	1	0	47	93	10	0	307
07:15	6	2	4	0	1	63	88	0	1	23	1	0	60	89	12	0	350
07:30	5	3	2	0	0	62	62	0	2	19	2	0	77	106	32	0	372
07:45	13	5	1	0	1	50	60	0	3	14	0	1	72	129	58	0	407
Total	31	12	9	0	3	230	277	0	12	72	4	1	256	417	112	0	1436
08:00	5	2	5	1	0	47	56	0	8	20	0	0	32	83	49	0	308
08:15	5	0	0	0	1	34	49	0	3	20	4	0	33	61	34	0	244
08:30	4	6	1	0	2	44	44	0	3	9	0	0	33	82	29	0	257
08:45	20	8	0	0	5	45	41	0	6	15	3	0	56	125	57	0	381
Total	34	16	6	1	8	170	190	0	20	64	7	0	154	351	169	0	1190
09:00	8	5	0	0	3	31	47	0	6	18	1	0	34	58	37	0	248
09:15	6	1	0	0	2	26	29	0	1	6	3	0	30	56	17	0	177
09:30	8	1	0	0	6	30	27	0	2	4	4	0	24	71	27	0	204
09:45	14	4	0	1	7	38	45	0	15	19	5	0	23	99	71	0	341
Total	36	11	0	1	18	125	148	0	24	47	13	0	111	284	152	0	970
10:00	5	6	1	0	6	38	49	0	10	19	4	0	24	84	39	0	285
10:15	9	5	1	0	2	21	40	0	3	10	3	0	25	74	34	0	227
10:30	1	1	1	0	2	36	38	0	4	10	9	1	19	58	20	0	200
10:45	9	1	2	0	4	29	37	0	11	22	2	0	23	79	34	0	253
Total	24	13	5	0	14	124	164	0	28	61	18	1	91	295	127	0	965
11:00	5	1	1	0	3	36	43	0	7	18	2	0	27	56	17	0	216
11:15	3	0	0	0	3	39	40	0	9	18	7	0	19	65	24	0	227
11:30	4	3	1	0	2	35	45	0	11	17	7	0	50	69	33	0	277
11:45	7	9	1	0	5	46	50	0	14	30	5	0	26	80	51	0	324
Total	19	13	3	0	13	156	178	0	41	83	21	0	122	270	125	0	1044
12:00	4	1	1	0	4	45	65	0	20	22	8	0	26	80	18	0	294
12:15	5	0	1	0	3	42	44	0	8	11	2	1	26	54	18	0	215
12:30	5	1	1	0	2	47	46	0	6	15	4	0	25	57	12	0	221
12:45	6	2	1	0	2	47	61	0	16	30	3	0	19	69	29	0	285
Total	20	4	4	0	11	181	216	0	50	78	17	1	96	260	77	0	1015
13:00	7	1	3	0	0	49	47	0	17	19	7	0	15	83	19	0	267
13:15	4	2	3	0	7	42	56	0	15	19	1	0	23	67	21	0	260
13:30	6	2	1	0	5	48	55	0	9	29	8	0	25	77	19	0	284
13:45	12	3	1	0	2	47	26	0	17	23	1	0	24	111	44	0	311
Total	29	8	8	0	14	186	184	0	58	90	17	0	87	338	103	0	1122
14:00	7	0	3	0	6	45	39	0	11	22	5	0	27	60	13	0	238
14:15	6	0	3	0	6	51	32	0	14	24	4	0	25	90	15	0	270
14:30	2	0	0	0	4	58	62	0	17	26	7	0	22	84	17	0	299
14:45	8	1	2	0	2	67	58	0	9	25	4	0	41	108	27	0	352
Total	23	1	8	0	18	221	191	0	51	97	20	0	115	342	72	0	1159
15:00	5	0	2	1	3	47	74	0	12	16	3	1	40	88	30	0	322
15:15	4	1	0	0	1	57	72	0	18	25	8	0	41	102	17	0	346
15:30	4	2	3	0	3	62	55	0	12	28	7	0	34	109	22	0	341
15:45	5	1	2	0	6	36	58	0	5	20	8	0	46	119	25	0	331
Total	18	4	7	1	13	202	259	0	47	89	26	1	161	418	94	0	1340

Albeck Gerken, Inc

Transportation Engineers

Traffic Data Collection

TH-52 at 80th St E., east ramp
 Inver Grove Heights, MN
 Ref.Pt.: 122.516
 TURN MOVEMENT COUNT

File Name : TH-52 at 80th St E east ramp 2012
 Site Code : 40
 Start Date : 1/13/2012
 Page No : 2

Groups Printed- Cars - Heavy Vehicles

Start Time	loop from / ramp to TH-52 NB Southbound				80th St E Westbound				Broderick Blvd Northbound				80th St E Eastbound				Int. Total
	Left	Thru	Right	Peds	Left	Thru	Right	Peds	Left	Thru	Right	Peds	Left	Thru	Right	Peds	
16:00	4	1	1	1	2	37	75	0	4	14	6	1	46	143	27	0	362
16:15	5	0	1	3	2	42	57	0	15	27	8	6	63	160	32	0	421
16:30	2	2	1	1	5	64	80	0	9	13	8	1	42	142	31	0	401
16:45	2	0	4	1	1	52	37	0	7	15	5	0	66	163	28	0	381
Total	13	3	7	6	10	195	249	0	35	69	27	8	217	608	118	0	1565
17:00	4	2	1	0	4	49	46	0	7	13	4	6	52	158	37	0	383
17:15	6	2	3	1	2	70	51	0	9	17	8	1	63	186	32	0	451
17:30	7	5	4	0	4	65	43	0	9	9	7	0	53	144	40	0	390
17:45	13	5	3	0	6	58	46	0	18	11	8	0	51	185	77	0	481
Total	30	14	11	1	16	242	186	0	43	50	27	7	219	673	186	0	1705
18:00	7	0	2	0	6	56	39	0	13	10	7	0	41	122	26	0	329
18:15	3	0	3	0	2	42	57	0	8	7	2	0	37	92	18	0	271
18:30	2	0	2	1	2	44	39	0	8	10	1	4	32	90	17	0	252
18:45	3	0	0	2	2	51	59	0	7	16	5	1	38	71	13	0	268
Total	15	0	7	3	12	193	194	0	36	43	15	5	148	375	74	0	1120
Grand Total	302	100	76	16	156	2359	2682	0	454	879	216	24	1931	4777	1423	0	15395
Apprch %	61.1	20.2	15.4	3.2	3	45.4	51.6	0	28.9	55.9	13.7	1.5	23.7	58.8	17.5	0	
Total %	2	0.6	0.5	0.1	1	15.3	17.4	0	2.9	5.7	1.4	0.2	12.5	31	9.2	0	
Cars	289	96	73	16	147	2287	2615	0	451	875	214	24	1765	4658	1408	0	14918
% Cars	95.7	96	96.1	100	94.2	96.9	97.5	0	99.3	99.5	99.1	100	91.4	97.5	98.9	0	96.9
Heavy Vehicles	13	4	3	0	9	72	67	0	3	4	2	0	166	119	15	0	477
% Heavy Vehicles	4.3	4	3.9	0	5.8	3.1	2.5	0	0.7	0.5	0.9	0	8.6	2.5	1.1	0	3.1

Albeck Gerken, Inc

Transportation Engineers

Traffic Data Collection

TH-52 at 80th St E., east ramp
 Inver Grove Heights, MN
 Ref.Pt.: 122.516
 TURN MOVEMENT COUNT

File Name : TH-52 at 80th St E east ramp 2012
 Site Code : 40
 Start Date : 1/13/2012
 Page No : 3

Start Time	loop from / ramp to TH-52 NB Southbound					80th St E Westbound					Broderick Blvd Northbound					80th St E Eastbound					Int. Total
	Left	Thru	Right	Peds	App. Total	Left	Thru	Right	Peds	App. Total	Left	Thru	Right	Peds	App. Total	Left	Thru	Right	Peds	App. Total	
Peak Hour Analysis From 06:00 to 08:45 - Peak 1 of 1																					
Peak Hour for Entire Intersection Begins at 07:15																					
07:15	6	2	4	0	12	1	63	88	0	152	1	23	1	0	25	60	89	12	0	161	350
07:30	5	3	2	0	10	0	62	62	0	124	2	19	2	0	23	77	106	32	0	215	372
07:45	13	5	1	0	19	1	50	60	0	111	3	14	0	1	18	72	129	58	0	259	407
08:00	5	2	5	1	13	0	47	56	0	103	8	20	0	0	28	32	83	49	0	164	308
Total Volume	29	12	12	1	54	2	222	266	0	490	14	76	3	1	94	241	407	151	0	799	1437
% App. Total	53.7	22.2	22.2	1.9		0.4	45.3	54.3	0		14.9	80.9	3.2	1.1		30.2	50.9	18.9	0		
PHF	.558	.600	.600	.250	.711	.500	.881	.756	.000	.806	.438	.826	.375	.250	.839	.782	.789	.651	.000	.771	.883

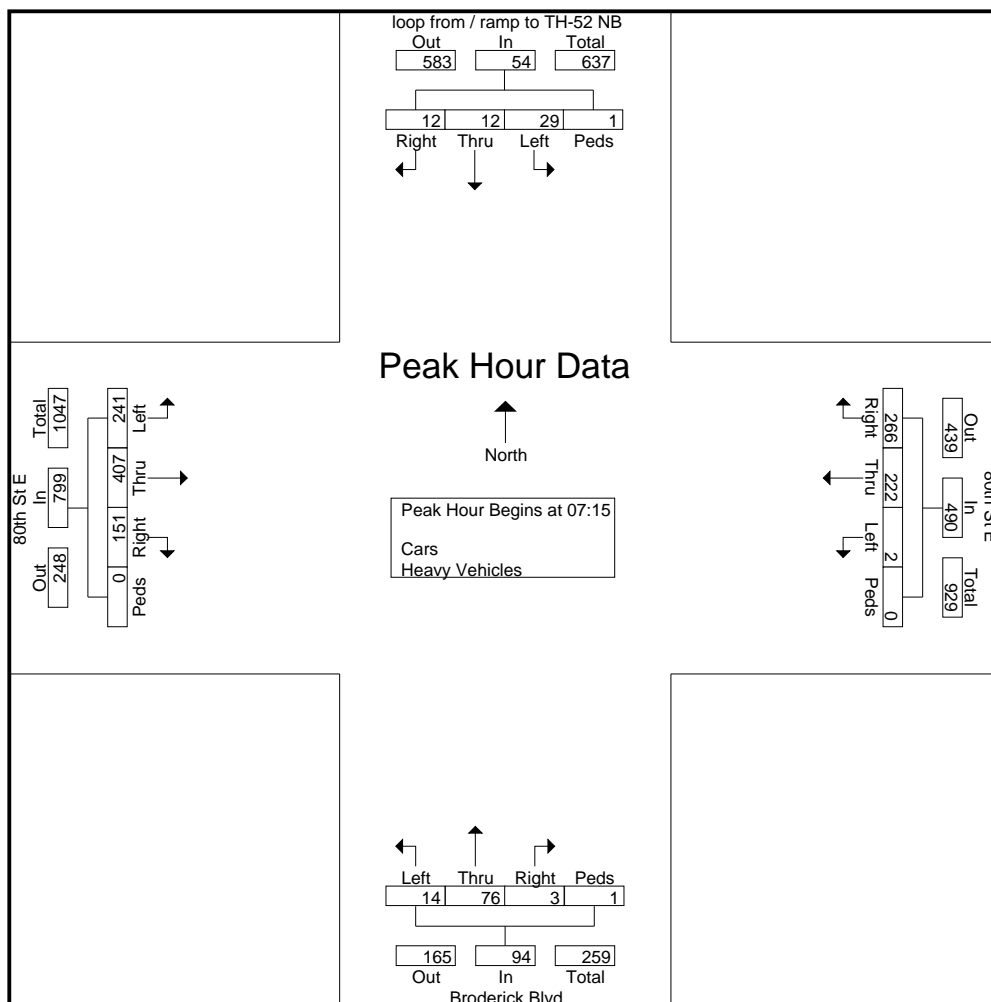

Albeck Gerken, Inc

Transportation Engineers

Traffic Data Collection

TH-52 at 80th St E., east ramp
 Inver Grove Heights, MN
 Ref.Pt.: 122.516
 TURN MOVEMENT COUNT

File Name : TH-52 at 80th St E east ramp 2012
 Site Code : 40
 Start Date : 1/13/2012
 Page No : 4

Start Time	loop from / ramp to TH-52 NB Southbound					80th St E Westbound					Broderick Blvd Northbound					80th St E Eastbound					Int. Total
	Left	Thru	Right	Peds	App. Total	Left	Thru	Right	Peds	App. Total	Left	Thru	Right	Peds	App. Total	Left	Thru	Right	Peds	App. Total	
Peak Hour Analysis From 15:00 to 18:00 - Peak 1 of 1																					
Peak Hour for Entire Intersection Begins at 17:00																					
17:00	4	2	1	0	7	4	49	46	0	99	7	13	4	6	30	52	158	37	0	247	383
17:15	6	2	3	1	12	2	70	51	0	123	9	17	8	1	35	63	186	32	0	281	451
17:30	7	5	4	0	16	4	65	43	0	112	9	9	7	0	25	53	144	40	0	237	390
17:45	13	5	3	0	21	6	58	46	0	110	18	11	8	0	37	51	185	77	0	313	481
Total Volume	30	14	11	1	56	16	242	186	0	444	43	50	27	7	127	219	673	186	0	1078	1705
% App. Total	53.6	25	19.6	1.8		3.6	54.5	41.9	0		33.9	39.4	21.3	5.5		20.3	62.4	17.3	0		
PHF	.577	.700	.688	.250	.667	.667	.864	.912	.000	.902	.597	.735	.844	.292	.858	.869	.905	.604	.000	.861	.886

