



# MINNESOTA DEPT OF TRANSPORTATION

## TRAFFIC DATA COLLECTION - METRO

TH-55 at Larch Lane PLYMOUTH  
 Ref.Pt.: 182.068  
 JAMAR # D4-3365 CH  
 TURN MOVEMENT COUNT

File Name : TH-55 at Larch Lane 2009  
 Site Code : 00000000  
 Start Date : 6/25/2009  
 Page No : 1

### Groups Printed- Cars & Trucks

Start Time	LARCH LANE Southbound				TH-55 Westbound				LARCH LANE Northbound				TH-55 Eastbound				Int. Total
	Left	Thru	Right	Peds	Left	Thru	Right	Peds	Left	Thru	Right	Peds	Left	Thru	Right	Peds	
06:00	0	0	0	0	1	86	0	0	0	0	1	0	0	139	0	0	227
06:15	0	0	0	0	3	102	0	0	0	0	1	0	0	238	1	1	346
06:30	0	0	0	0	0	180	0	0	2	0	1	0	0	291	2	1	477
06:45	0	0	1	0	2	217	1	0	2	0	5	0	1	377	1	0	607
Total	0	0	1	0	6	585	1	0	4	0	8	0	1	1045	4	2	1657
07:00	0	0	3	0	2	206	1	1	2	0	4	0	0	466	0	0	685
07:15	0	0	3	0	2	240	1	0	1	0	3	0	1	482	4	0	737
07:30	0	0	0	0	0	293	0	0	6	0	8	0	1	561	3	0	872
07:45	0	0	4	0	7	360	0	0	2	0	2	0	0	563	3	0	941
Total	0	0	10	0	11	1099	2	1	11	0	17	0	2	2072	10	0	3235
08:00	0	0	4	0	5	281	5	0	6	0	9	0	2	501	6	0	819
08:15	0	0	1	0	10	278	2	0	0	0	3	1	0	471	2	0	768
08:30	2	0	1	0	4	229	1	0	5	0	7	0	2	462	5	0	718
08:45	0	0	3	0	8	271	0	0	5	1	9	0	3	367	2	0	669
Total	2	0	9	0	27	1059	8	0	16	1	28	1	7	1801	15	0	2974
15:00	8	3	0	0	3	364	1	0	5	1	7	0	1	311	4	1	709
15:15	4	0	1	0	10	385	1	0	3	1	3	0	3	287	5	1	704
15:30	2	0	1	0	4	366	0	0	1	0	5	0	3	435	3	1	821
15:45	0	0	1	0	5	400	2	0	4	1	2	0	1	337	4	0	757
Total	14	3	3	0	22	1515	4	0	13	3	17	0	8	1370	16	3	2991
16:00	2	0	5	0	5	474	3	0	5	0	7	0	3	386	5	0	895
16:15	0	0	4	0	8	474	1	0	5	0	6	0	0	344	9	0	851
16:30	2	0	4	0	6	499	2	0	4	1	7	0	7	438	8	0	978
16:45	1	0	2	0	7	532	1	0	3	0	9	0	3	388	6	0	952
Total	5	0	15	0	26	1979	7	0	17	1	29	0	13	1556	28	0	3676
17:00	1	0	3	1	10	528	0	1	4	0	3	1	4	513	8	0	1077
17:15	1	0	2	0	8	541	0	0	12	0	11	0	4	418	11	1	1009
17:30	1	0	2	0	4	482	0	0	2	2	6	0	4	393	4	1	901
17:45	2	1	1	0	7	470	2	0	5	0	4	0	3	292	5	0	792
Total	5	1	8	1	29	2021	2	1	23	2	24	1	15	1616	28	2	3779
Grand Total	26	4	46	1	121	8258	24	2	84	7	123	2	46	9460	101	7	18312
Apprch %	33.8	5.2	59.7	1.3	1.4	98.3	0.3	0	38.9	3.2	56.9	0.9	0.5	98.4	1.1	0.1	
Total %	0.1	0	0.3	0	0.7	45.1	0.1	0	0.5	0	0.7	0	0.3	51.7	0.6	0	



# MINNESOTA DEPT OF TRANSPORTATION

## TRAFFIC DATA COLLECTION - METRO

TH-55 at Larch Lane PLYMOUTH  
 Ref.Pt.: 182.068  
 JAMAR # D4-3365 CH  
 TURN MOVEMENT COUNT

File Name : TH-55 at Larch Lane 2009  
 Site Code : 00000000  
 Start Date : 6/25/2009  
 Page No : 2

Start Time	LARCH LANE Southbound					TH-55 Westbound					LARCH LANE Northbound					TH-55 Eastbound					Int. Total
	Left	Thru	Right	Peds	App. Total	Left	Thru	Right	Peds	App. Total	Left	Thru	Right	Peds	App. Total	Left	Thru	Right	Peds	App. Total	
Peak Hour Analysis From 06:00 to 08:45 - Peak 1 of 1																					
Peak Hour for Entire Intersection Begins at 07:30																					
07:30	0	0	0	0	0	0	293	0	0	293	6	0	8	0	14	1	561	3	0	565	872
07:45	0	0	4	0	4	7	360	0	0	367	2	0	2	0	4	0	563	3	0	566	941
08:00	0	0	4	0	4	5	281	5	0	291	6	0	9	0	15	2	501	6	0	509	819
08:15	0	0	1	0	1	10	278	2	0	290	0	0	3	1	4	0	471	2	0	473	768
Total Volume	0	0	9	0	9	22	1212	7	0	1241	14	0	22	1	37	3	2096	14	0	2113	3400
% App. Total	0	0	100	0		1.8	97.7	0.6	0		37.8	0	59.5	2.7		0.1	99.2	0.7	0		
PHF	.000	.000	.563	.000	.563	.550	.842	.350	.000	.845	.583	.000	.611	.250	.617	.375	.931	.583	.000	.933	.903

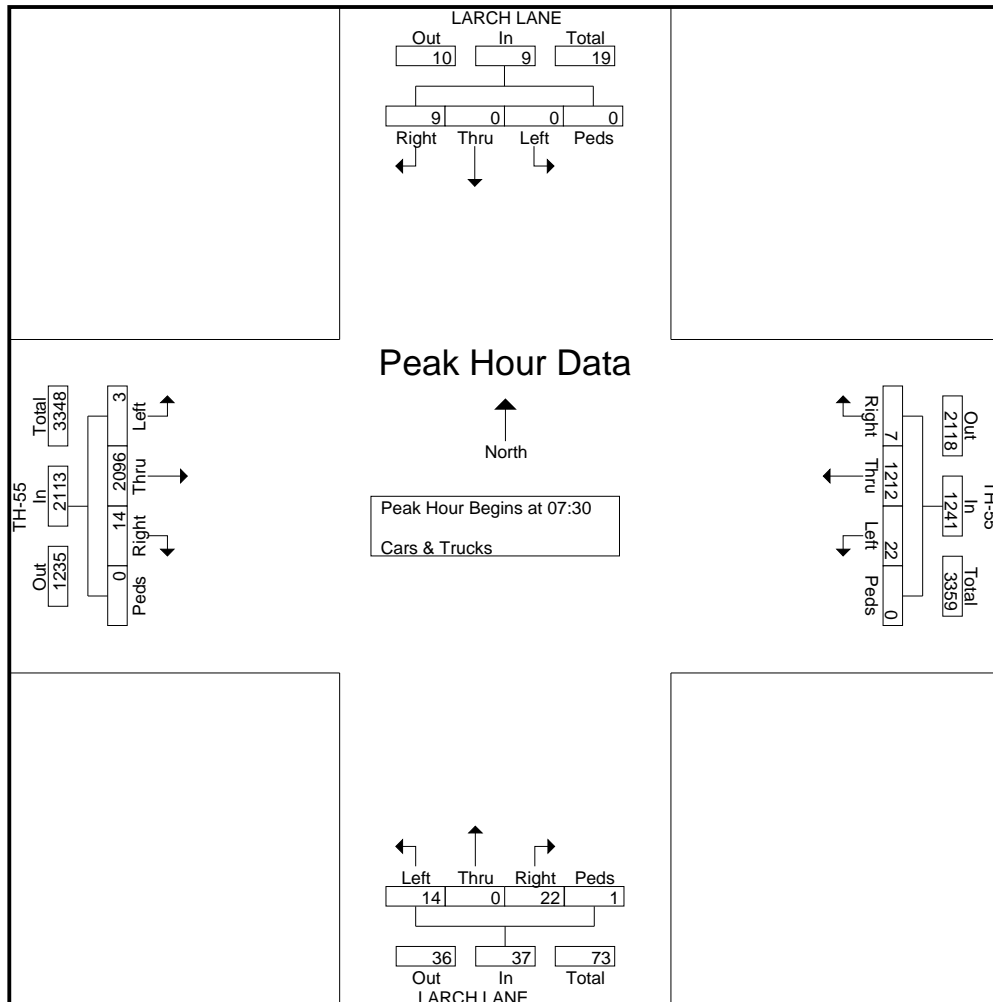



# MINNESOTA DEPT OF TRANSPORTATION

## TRAFFIC DATA COLLECTION - METRO

TH-55 at Larch Lane PLYMOUTH  
 Ref.Pt.: 182.068  
 JAMAR # D4-3365 CH  
 TURN MOVEMENT COUNT

File Name : TH-55 at Larch Lane 2009  
 Site Code : 00000000  
 Start Date : 6/25/2009  
 Page No : 3

Start Time	LARCH LANE Southbound					TH-55 Westbound					LARCH LANE Northbound					TH-55 Eastbound					Int. Total
	Left	Thru	Right	Peds	App. Total	Left	Thru	Right	Peds	App. Total	Left	Thru	Right	Peds	App. Total	Left	Thru	Right	Peds	App. Total	
Peak Hour Analysis From 15:00 to 17:45 - Peak 1 of 1																					
Peak Hour for Entire Intersection Begins at 16:30																					
16:30	2	0	4	0	6	6	499	2	0	507	4	1	7	0	12	7	438	8	0	453	978
16:45	1	0	2	0	3	7	532	1	0	540	3	0	9	0	12	3	388	6	0	397	952
17:00	1	0	3	1	5	10	528	0	1	539	4	0	3	1	8	4	513	8	0	525	1077
17:15	1	0	2	0	3	8	541	0	0	549	12	0	11	0	23	4	418	11	1	434	1009
Total Volume	5	0	11	1	17	31	2100	3	1	2135	23	1	30	1	55	18	1757	33	1	1809	4016
% App. Total	29.4	0	64.7	5.9		1.5	98.4	0.1	0		41.8	1.8	54.5	1.8		1	97.1	1.8	0.1		
PHF	.625	.000	.688	.250	.708	.775	.970	.375	.250	.972	.479	.250	.682	.250	.598	.643	.856	.750	.250	.861	.932

