

Alliant Engineering, Inc.

233 Park Ave Suite 300
 Minneapolis, MN 55415

--TRAFFIC DATA--

TH 55 and Rhode Island Avenue
 Ref.Pt.: 185.227
 data by : Alliant Inc.
 TURN MOVEMENT COUNT

File Name : 422_TH 55 & Rhode Island Ave
 Site Code : 422_____
 Start Date : 2/15/2018
 Page No : 1

Groups Printed- Class 1 - Class 2

Start Time	Rhode Island Ave From North					TH 55 From East					Rhode Island Ave From South					TH 55 From West					Int. Total
	Other	Right	Thru	Left	App. Total	Other	Right	Thru	Left	App. Total	Other	Right	Thru	Left	App. Total	Other	Right	Thru	Left	App. Total	
06:00 AM	0	3	0	7	10	0	1	126	0	127	0	0	0	0	0	0	0	123	7	130	267
06:15 AM	0	5	0	5	10	0	12	144	0	156	0	0	0	0	0	0	0	189	7	196	362
06:30 AM	0	5	0	16	21	0	15	205	0	220	0	0	0	0	0	0	0	233	14	247	488
06:45 AM	0	16	0	19	35	0	19	215	0	234	0	0	0	0	0	0	0	283	23	306	575
Total	0	29	0	47	76	0	47	690	0	737	0	0	0	0	0	0	0	828	51	879	1692
07:00 AM	0	12	0	22	34	0	13	252	0	265	0	0	0	0	0	0	0	446	12	458	757
07:15 AM	0	21	0	45	66	0	24	261	0	285	1	0	0	0	1	0	0	532	13	545	897
07:30 AM	0	21	0	37	58	0	19	293	0	312	0	0	0	0	0	0	0	624	10	634	1004
07:45 AM	0	12	0	44	56	0	20	357	0	377	0	0	0	0	0	0	0	629	21	650	1083
Total	0	66	0	148	214	0	76	1163	0	1239	1	0	0	0	1	0	0	2231	56	2287	3741
08:00 AM	0	23	0	36	59	0	29	343	0	372	0	0	0	0	0	0	0	618	20	638	1069
08:15 AM	0	33	0	47	80	0	27	300	0	327	0	0	0	0	0	0	0	522	23	545	952
08:30 AM	0	23	0	50	73	0	22	292	0	314	0	0	0	0	0	0	0	512	22	534	921
08:45 AM	0	21	0	14	35	0	23	302	0	325	0	0	0	0	0	0	0	427	24	451	811
Total	0	100	0	147	247	0	101	1237	0	1338	0	0	0	0	0	0	0	2079	89	2168	3753
09:00 AM	0	26	0	25	51	0	23	183	0	206	0	0	0	0	0	0	0	298	23	321	578
09:15 AM	0	14	0	37	51	0	21	226	0	247	0	0	0	0	0	0	0	230	10	240	538
*** BREAK ***																					
Total	0	40	0	62	102	0	44	409	0	453	0	0	0	0	0	0	0	528	33	561	1116
*** BREAK ***																					
10:30 AM	0	23	0	31	54	0	22	162	0	184	0	0	0	0	0	0	0	166	11	177	415
10:45 AM	0	17	0	29	46	0	25	197	0	222	0	0	0	0	0	0	0	197	15	212	480
Total	0	40	0	60	100	0	47	359	0	406	0	0	0	0	0	0	0	363	26	389	895
11:00 AM	0	27	0	37	64	0	23	193	0	216	0	0	0	0	0	0	0	212	17	229	509
11:15 AM	0	34	0	36	70	0	24	217	0	241	0	0	0	0	0	0	0	213	17	230	541
11:30 AM	0	36	0	44	80	0	24	188	0	212	0	0	0	0	0	0	0	196	20	216	508
11:45 AM	0	45	0	33	78	0	29	205	0	234	0	0	0	0	0	0	0	217	19	236	548
Total	0	142	0	150	292	0	100	803	0	903	0	0	0	0	0	0	0	838	73	911	2106
12:00 PM	0	39	0	43	82	0	35	224	0	259	0	0	0	0	0	0	0	220	26	246	587
12:15 PM	0	34	0	35	69	0	44	234	0	278	0	0	0	0	0	0	0	237	26	263	610
12:30 PM	0	40	0	36	76	0	18	236	0	254	0	0	0	0	0	0	0	225	26	251	581
12:45 PM	0	37	0	52	89	0	21	234	0	255	0	0	0	0	0	0	0	266	27	293	637
Total	0	150	0	166	316	0	118	928	0	1046	0	0	0	0	0	0	0	948	105	1053	2415
01:00 PM	0	27	0	52	79	0	37	192	2	231	0	0	0	0	0	0	0	251	19	270	580
01:15 PM	0	35	0	40	75	0	28	181	0	209	0	0	0	0	0	0	0	203	17	220	504
*** BREAK ***																					
Total	0	62	0	92	154	0	65	373	2	440	0	0	0	0	0	0	0	454	36	490	1084
*** BREAK ***																					
02:30 PM	0	38	0	21	59	0	28	247	0	275	0	0	0	0	0	0	0	272	15	287	621
02:45 PM	0	27	0	30	57	0	16	262	0	278	0	0	0	0	0	0	0	279	17	296	631
Total	0	65	0	51	116	0	44	509	0	553	0	0	0	0	0	0	0	551	32	583	1252
03:00 PM	0	38	0	37	75	0	21	299	0	320	0	0	0	0	0	1	0	343	10	354	749
03:15 PM	0	26	0	40	66	0	24	265	0	289	0	0	0	0	0	2	0	321	23	346	701
03:30 PM	0	37	0	37	74	0	20	349	0	369	0	0	0	0	0	0	0	396	11	407	850
03:45 PM	0	30	0	74	104	0	30	326	0	356	0	0	0	0	0	0	0	409	17	426	886
Total	0	131	0	188	319	0	95	1239	0	1334	0	0	0	0	0	3	0	1469	61	1533	3186
04:00 PM	0	33	0	40	73	0	30	379	0	409	0	0	0	0	0	3	0	406	12	421	903
04:15 PM	0	20	0	41	61	0	22	455	0	477	0	0	0	0	0	0	0	516	30	546	1084
04:30 PM	0	34	0	53	87	0	16	394	0	410	0	0	0	0	0	0	0	568	24	592	1089

Alliant Engineering, Inc.

233 Park Ave Suite 300

Minneapolis, MN 55415

--TRAFFIC DATA--

TH 55 and Rhode Island Avenue

Ref.Pt.: 185.227

data by : Alliant Inc.

TURN MOVEMENT COUNT

File Name : 422_TH 55 & Rhode Island Ave

Site Code : 422_____

Start Date : 2/15/2018

Page No : 2

Groups Printed- Class 1 - Class 2

Start Time	Rhode Island Ave From North					TH 55 From East					Rhode Island Ave From South					TH 55 From West					Int. Total
	Other	Rght	Thru	Left	App. Total	Other	Rght	Thru	Left	App. Total	Other	Rght	Thru	Left	App. Total	Other	Rght	Thru	Left	App. Total	
04:45 PM	0	45	0	57	102	0	20	474	0	494	0	0	0	0	0	0	0	561	14	575	1171
Total	0	132	0	191	323	0	88	1702	0	1790	0	0	0	0	0	3	0	2051	80	2134	4247
05:00 PM	0	48	0	47	95	0	9	445	0	454	0	0	0	0	0	0	0	584	22	606	1155
05:15 PM	0	34	0	50	84	0	12	439	0	451	0	0	0	0	0	0	0	605	25	630	1165
05:30 PM	0	25	0	56	81	0	21	376	0	397	0	0	0	0	0	1	0	459	16	476	954
05:45 PM	0	29	0	32	61	0	15	360	0	375	0	0	0	0	0	0	0	406	16	422	858
Total	0	136	0	185	321	0	57	1620	0	1677	0	0	0	0	0	1	0	2054	79	2134	4132
Grand Total	0	1093	0	1487	2580	0	882	11032	2	11916	1	0	0	0	1	7	0	14394	721	15122	29619
Apprch %	0	42.4	0	57.6		0	7.4	92.6	0		100	0	0	0		0	0	95.2	4.8		
Total %	0	3.7	0	5	8.7	0	3	37.2	0	40.2	0	0	0	0	0	0	0	48.6	2.4	51.1	
Class 1	0	1074	0	1468	2542	0	866	10619	2	11487	1	0	0	0	1	7	0	13952	709	14668	28698
% Class 1	0	98.3	0	98.7	98.5	0	98.2	96.3	100	96.4	100	0	0	0	100	100	0	96.9	98.3	97	96.9
Class 2	0	19	0	19	38	0	16	413	0	429	0	0	0	0	0	0	0	442	12	454	921
% Class 2	0	1.7	0	1.3	1.5	0	1.8	3.7	0	3.6	0	0	0	0	0	0	0	3.1	1.7	3	3.1

Alliant Engineering, Inc.

233 Park Ave Suite 300

Minneapolis, MN 55415

--TRAFFIC DATA--

TH 55 and Rhode Island Avenue

Ref.Pt.: 185.227

data by : Alliant Inc.

TURN MOVEMENT COUNT

File Name : 422_TH 55 & Rhode Island Ave

Site Code : 422_____

Start Date : 2/15/2018

Page No : 3

Start Time	Rhode Island Ave From North					TH 55 From East					Rhode Island Ave From South					TH 55 From West					Int. Total
	Other	Right	Thru	Left	App. Total	Other	Right	Thru	Left	App. Total	Other	Right	Thru	Left	App. Total	Other	Right	Thru	Left	App. Total	
Peak Hour Analysis From 06:00 AM to 11:45 AM - Peak 1 of 1																					
Peak Hour for Entire Intersection Begins at 07:30 AM																					
07:30 AM	0	21	0	37	58	0	19	293	0	312	0	0	0	0	0	0	0	624	10	634	1004
07:45 AM	0	12	0	44	56	0	20	357	0	377	0	0	0	0	0	0	0	629	21	650	1083
08:00 AM	0	23	0	36	59	0	29	343	0	372	0	0	0	0	0	0	0	618	20	638	1069
08:15 AM	0	33	0	47	80	0	27	300	0	327	0	0	0	0	0	0	0	522	23	545	952
Total Volume	0	89	0	164	253	0	95	1293	0	1388	0	0	0	0	0	0	0	2393	74	2467	4108
% App. Total	0	35.2	0	64.8		0	6.8	93.2	0		0	0	0	0	0	0	0	97	3		
PHF	.000	.674	.000	.872	.791	.000	.819	.905	.000	.920	.000	.000	.000	.000	.000	.000	.000	.951	.804	.949	.948

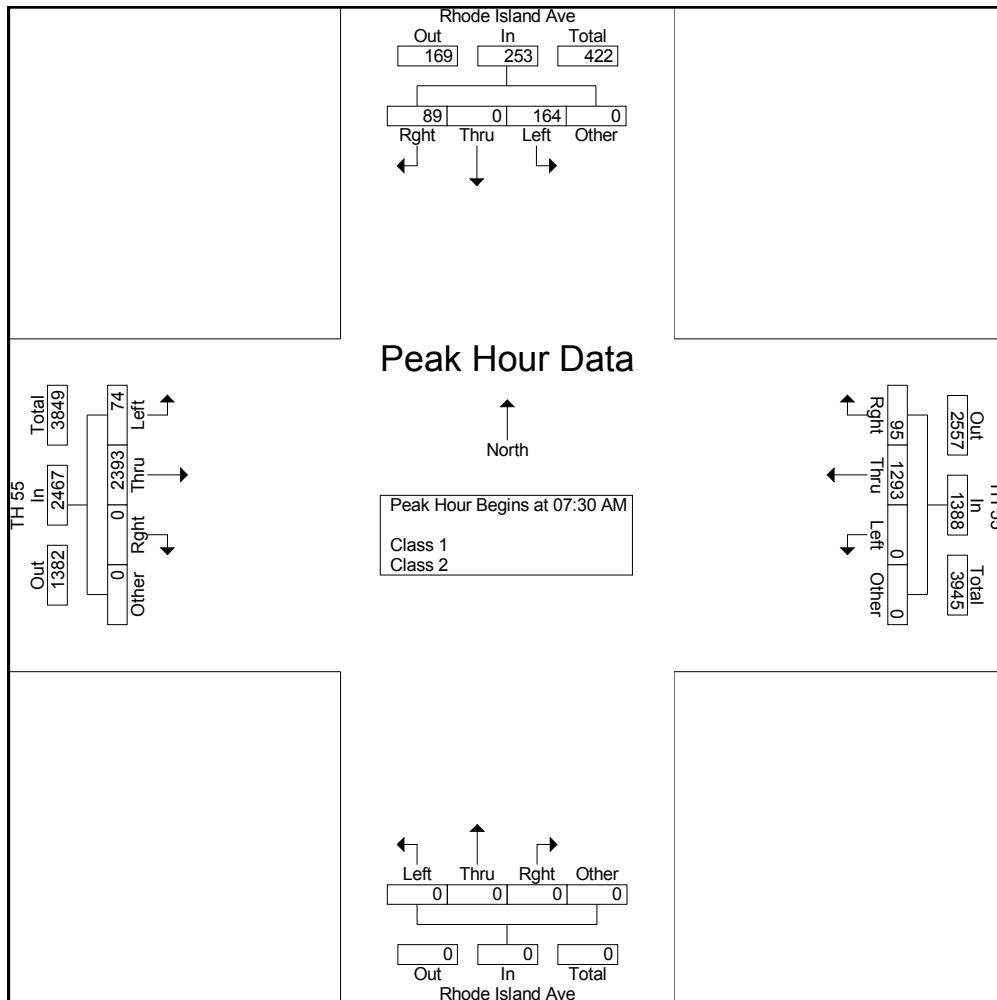

Alliant Engineering, Inc.

233 Park Ave Suite 300
 Minneapolis, MN 55415
 --TRAFFIC DATA--

TH 55 and Rhode Island Avenue
 Ref.Pt.: 185.227
 data by : Alliant Inc.
 TURN MOVEMENT COUNT

File Name : 422_TH 55 & Rhode Island Ave
 Site Code : 422_____
 Start Date : 2/15/2018
 Page No : 4

Start Time	Rhode Island Ave From North					TH 55 From East					Rhode Island Ave From South					TH 55 From West					Int. Total
	Other	Rgh t	Thru	Left	App. Total	Other	Rgh t	Thru	Left	App. Total	Other	Rgh t	Thru	Left	App. Total	Other	Rgh t	Thru	Left	App. Total	
Peak Hour Analysis From 12:00 PM to 05:45 PM - Peak 1 of 1																					
Peak Hour for Entire Intersection Begins at 04:30 PM																					
04:30 PM	0	34	0	53	87	0	16	394	0	410	0	0	0	0	0	0	0	568	24	592	1089
04:45 PM	0	45	0	57	102	0	20	474	0	494	0	0	0	0	0	0	0	561	14	575	1171
05:00 PM	0	48	0	47	95	0	9	445	0	454	0	0	0	0	0	0	0	584	22	606	1155
05:15 PM	0	34	0	50	84	0	12	439	0	451	0	0	0	0	0	0	0	605	25	630	1165
Total Volume	0	161	0	207	368	0	57	1752	0	1809	0	0	0	0	0	0	0	2318	85	2403	4580
% App. Total	0	43.8	0	56.2		0	3.2	96.8	0		0	0	0	0	0	0	0	96.5	3.5		
PHF	.000	.839	.000	.908	.902	.000	.713	.924	.000	.915	.000	.000	.000	.000	.000	.000	.000	.958	.850	.954	.978

