

Alliant Engineering

Minneapolis, MN 55415

--TRAFFIC DATA --

TH-55 / 149 at Holiday Lane

File Name : 114 - TH 55 & Holiday Lane

Site Code : 114

BY: Alliant Eng.

Start Date : 11/18/2014

TURN MOVEMENT COUNT

Page No : 1

Groups Printed- Cars - Trucks

Start Time	Holiday Lane Southbound				TH 55 Westbound				TH 149 Northbound				TH 55/149 Eastbound				Int. Total
	Left	Thru	Rght	Bikes	Left	Thru	Rght	Bikes	Left	Thru	Rght	Bikes	Left	Thru	Rght	Bikes	
06:00	2	3	15	0	0	125	19	0	76	16	3	0	4	57	56	0	376
06:15	5	10	18	0	3	180	19	0	107	14	4	0	4	59	91	0	514
06:30	4	7	11	0	10	222	14	0	145	32	3	0	3	83	108	0	642
06:45	3	13	21	0	11	200	9	0	154	26	2	0	5	77	123	0	644
Total	14	33	65	0	24	727	61	0	482	88	12	0	16	276	378	0	2176
07:00	5	15	7	0	4	262	11	0	174	39	8	0	10	76	131	0	742
07:15	6	7	18	0	5	251	18	0	168	38	5	0	5	72	170	0	763
07:30	5	8	11	0	4	265	11	0	188	53	7	0	5	96	182	0	835
07:45	3	21	14	0	11	277	8	0	172	94	8	0	7	91	201	0	907
Total	19	51	50	0	24	1055	48	0	702	224	28	0	27	335	684	0	3247
08:00	6	6	25	0	4	187	9	0	140	51	2	0	4	76	173	0	683
08:15	7	5	15	0	0	179	7	0	107	42	6	0	6	69	181	0	624
08:30	3	5	14	0	4	163	8	0	102	36	2	0	7	93	139	0	576
08:45	6	13	17	0	11	115	10	0	83	28	7	0	6	79	164	0	539
Total	22	29	71	0	19	644	34	0	432	157	17	0	23	317	657	0	2422
09:00	4	7	14	0	6	124	4	0	123	18	3	0	11	74	108	0	496
09:15	6	7	14	0	1	119	11	0	106	18	5	0	9	95	98	0	489
*** BREAK ***																	
Total	10	14	28	0	7	243	15	0	229	36	8	0	20	169	206	0	985
*** BREAK ***																	
10:30	0	7	11	0	9	98	5	0	75	12	3	0	6	68	57	0	351
10:45	7	4	7	0	4	108	5	0	70	11	7	0	5	62	78	0	368
Total	7	11	18	0	13	206	10	0	145	23	10	0	11	130	135	0	719
11:00	5	9	12	0	8	73	6	0	74	12	8	0	4	73	70	0	354
11:15	4	16	22	0	6	85	6	0	81	18	7	0	2	72	79	0	398
11:30	6	21	12	0	7	89	10	0	67	13	11	0	5	71	98	0	410
11:45	10	17	19	0	7	111	14	4	84	13	7	0	3	89	96	0	474
Total	25	63	65	0	28	358	36	4	306	56	33	0	14	305	343	0	1636
12:00	4	10	19	0	14	103	11	0	60	30	12	0	6	91	82	0	442
12:15	7	26	22	0	8	93	6	0	70	13	5	0	5	73	67	0	395
12:30	15	17	22	0	8	123	7	0	78	22	6	0	6	102	72	0	478
12:45	5	23	23	0	3	84	10	0	73	21	5	0	1	100	62	0	410
Total	31	76	86	0	33	403	34	0	281	86	28	0	18	366	283	0	1725
13:00	9	12	14	0	6	104	10	0	61	15	12	0	9	86	68	0	406
13:15	9	9	13	0	4	97	6	0	49	24	5	0	3	82	72	0	373
13:30	0	0	0	0	0	1	0	0	6	1	1	0	0	2	5	0	16
*** BREAK ***																	
Total	18	21	27	0	10	202	16	0	116	40	18	0	12	170	145	0	795
*** BREAK ***																	
14:30	2	13	16	0	4	119	12	0	96	9	9	0	2	133	91	0	506
14:45	4	16	14	0	3	109	13	0	61	14	12	0	3	148	90	0	487
Total	6	29	30	0	7	228	25	0	157	23	21	0	5	281	181	0	993
15:00	5	18	16	0	6	105	4	0	120	20	12	0	3	146	94	0	549
15:15	17	35	14	0	1	100	7	0	111	13	6	0	15	151	103	0	573
15:30	17	27	15	0	4	106	10	0	149	18	14	0	2	173	116	0	651
15:45	9	17	15	0	2	111	13	1	122	30	5	0	2	200	138	0	665
Total	48	97	60	0	13	422	34	1	502	81	37	0	22	670	451	0	2438
16:00	14	38	14	0	10	104	9	0	165	15	14	0	3	195	138	0	719
16:15	14	24	13	0	6	102	4	0	144	15	17	0	8	196	143	0	686

Alliant Engineering

Minneapolis, MN 55415

--TRAFFIC DATA --

TH-55 / 149 at Holiday Lane

File Name : 114 - TH 55 & Holiday Lane

Site Code : 114

BY: Alliant Eng.

Start Date : 11/18/2014

TURN MOVEMENT COUNT

Page No : 2

Groups Printed- Cars - Trucks

Start Time	Holiday Lane Southbound				TH 55 Westbound				TH 149 Northbound				TH 55/149 Eastbound				Int. Total
	Left	Thru	Rght	Bikes	Left	Thru	Rght	Bikes	Left	Thru	Rght	Bikes	Left	Thru	Rght	Bikes	
16:30	26	32	14	0	9	137	6	0	173	32	31	0	1	290	189	0	940
16:45	22	38	15	0	3	117	7	0	152	26	16	0	2	222	171	0	791
Total	76	132	56	0	28	460	26	0	634	88	78	0	14	903	641	0	3136
17:00	21	38	13	0	2	130	5	0	175	17	17	0	0	270	199	0	887
17:15	19	48	19	0	7	111	3	1	167	13	17	0	3	223	208	0	839
17:30	9	21	16	0	11	129	6	0	152	9	14	0	5	236	139	0	747
17:45	14	26	14	0	4	124	11	0	108	15	10	0	8	185	138	0	657
Total	63	133	62	0	24	494	25	1	602	54	58	0	16	914	684	0	3130
Grand Total	339	689	618	0	230	5442	364	6	4588	956	348	0	198	4836	4788	0	23402
Apprch %	20.6	41.9	37.5	0	3.8	90.1	6	0.1	77.9	16.2	5.9	0	2	49.2	48.7	0	
Total %	1.4	2.9	2.6	0	1	23.3	1.6	0	19.6	4.1	1.5	0	0.8	20.7	20.5	0	
Cars	331	675	593	0	190	5049	346	3	4183	920	317	0	178	4467	4290	0	21542
% Cars	97.6	98	96	0	82.6	92.8	95.1	50	91.2	96.2	91.1	0	89.9	92.4	89.6	0	92.1
Trucks	8	14	25	0	40	393	18	3	405	36	31	0	20	369	498	0	1860
% Trucks	2.4	2	4	0	17.4	7.2	4.9	50	8.8	3.8	8.9	0	10.1	7.6	10.4	0	7.9

Alliant Engineering

Minneapolis, MN 55415

--TRAFFIC DATA --

TH-55 / 149 at Holiday Lane

File Name : 114 - TH 55 & Holiday Lane

Site Code : 114

Start Date : 11/18/2014

Page No : 3

BY: Alliant Eng.

TURN MOVEMENT COUNT

Start Time	Holiday Lane Southbound					TH 55 Westbound					TH 149 Northbound					TH 55/149 Eastbound					Int. Total
	Left	Thru	Right	Bikes	App. Total	Left	Thru	Right	Bikes	App. Total	Left	Thru	Right	Bikes	App. Total	Left	Thru	Right	Bikes	App. Total	
Peak Hour Analysis From 06:00 to 11:45 - Peak 1 of 1																					
Peak Hour for Entire Intersection Begins at 07:00																					
07:00	5	15	7	0	27	4	262	11	0	277	174	39	8	0	221	10	76	131	0	217	742
07:15	6	7	18	0	31	5	251	18	0	274	168	38	5	0	211	5	72	170	0	247	763
07:30	5	8	11	0	24	4	265	11	0	280	188	53	7	0	248	5	96	182	0	283	835
07:45	3	21	14	0	38	11	277	8	0	296	172	94	8	0	274	7	91	201	0	299	907
Total Volume	19	51	50	0	120	24	1055	48	0	1127	702	224	28	0	954	27	335	684	0	1046	3247
% App. Total	15.8	42.5	41.7	0		2.1	93.6	4.3	0		73.6	23.5	2.9	0		2.6	32	65.4	0		
PHF	.792	.607	.694	.000	.789	.545	.952	.667	.000	.952	.934	.596	.875	.000	.870	.675	.872	.851	.000	.875	.895

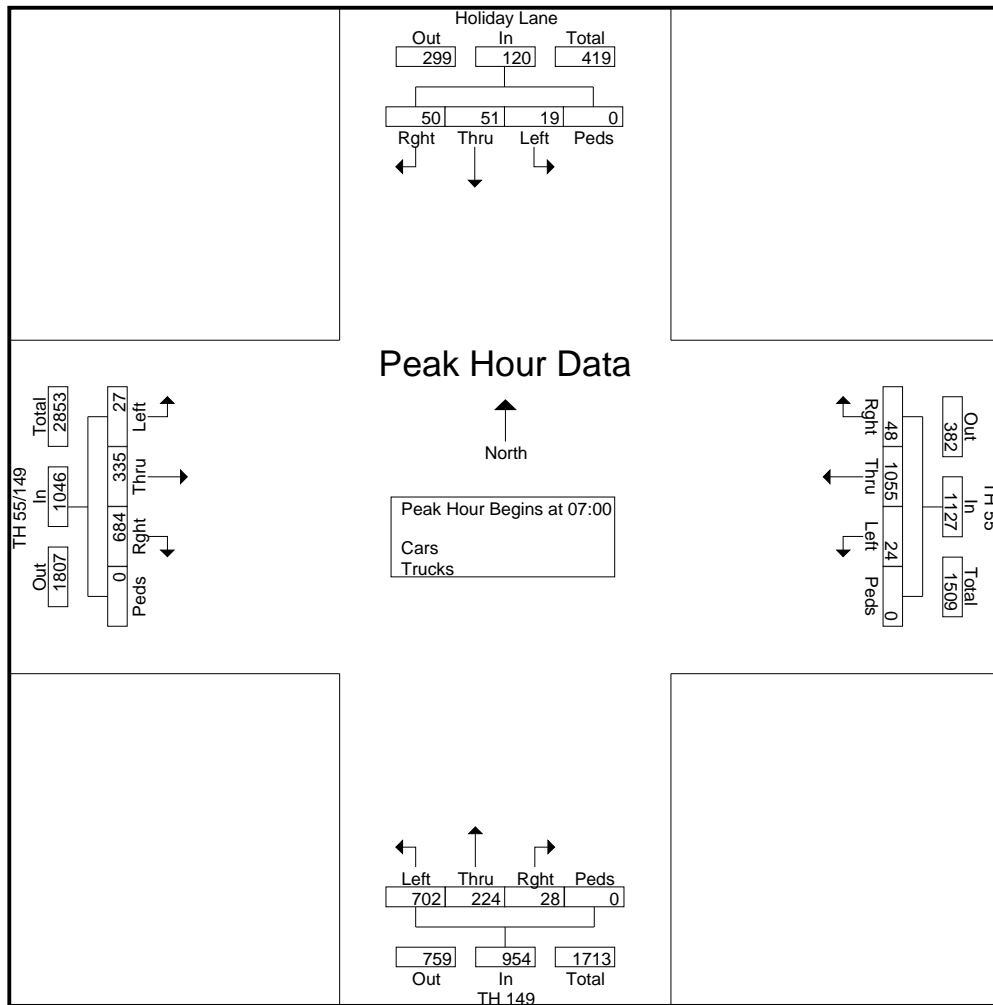

Alliant Engineering

Minneapolis, MN 55415

--TRAFFIC DATA --

TH-55 / 149 at Holiday Lane

File Name : 114 - TH 55 & Holiday Lane

Site Code : 114

BY: Alliant Eng.

Start Date : 11/18/2014

TURN MOVEMENT COUNT

Page No : 4

Start Time	Holiday Lane Southbound					TH 55 Westbound					TH 149 Northbound					TH 55/149 Eastbound					Int. Total
	Left	Thru	Rght	Bikes	App. Total	Left	Thru	Rght	Bikes	App. Total	Left	Thru	Rght	Bikes	App. Total	Left	Thru	Rght	Bikes	App. Total	
Peak Hour Analysis From 12:00 to 17:45 - Peak 1 of 1																					
Peak Hour for Entire Intersection Begins at 16:30																					
16:30	26	32	14	0	72	9	137	6	0	152	173	32	31	0	236	1	290	189	0	480	940
16:45	22	38	15	0	75	3	117	7	0	127	152	26	16	0	194	2	222	171	0	395	791
17:00	21	38	13	0	72	2	130	5	0	137	175	17	17	0	209	0	270	199	0	469	887
17:15	19	48	19	0	86	7	111	3	1	122	167	13	17	0	197	3	223	208	0	434	839
Total Volume	88	156	61	0	305	21	495	21	1	538	667	88	81	0	836	6	1005	767	0	1778	3457
% App. Total	28.9	51.1	20	0		3.9	92	3.9	0.2		79.8	10.5	9.7	0		0.3	56.5	43.1	0		
PHF	.846	.813	.803	.000	.887	.583	.903	.750	.250	.885	.953	.688	.653	.000	.886	.500	.866	.922	.000	.926	.919

