



# MINNESOTA DEPT OF TRANSPORTATION

## TRAFFIC COLLECTION - METRO

Location: TH 61 AT 10TH ST  
 REF.PT: 116+00.921  
 JAMAR#632\DR  
 TURN MOVEMENT COUNT

File Name : TH 61 AT 10TH ST AM NOON PM 2006  
 Site Code : 00000000  
 Start Date : 2/7/2006  
 Page No : 1

### Groups Printed- Cars & Trucks

Start Time	TH 61 Southbound					10TH ST NOON Westbound					TH 61 Northbound					10TH ST NOON Eastbound					Int. Total
	Right	Thru	Left	Peds	App. Total	Right	Thru	Left	Peds	App. Total	Right	Thru	Left	Peds	App. Total	Right	Thru	Left	Peds	App. Total	
06:00	0	121	22	0	143	20	4	10	0	34	10	125	0	0	135	0	0	0	0	0	312
06:15	1	157	26	0	184	28	3	4	0	35	8	157	1	0	166	0	1	0	0	1	386
06:30	2	204	30	0	236	21	9	7	0	37	20	210	0	0	230	0	5	2	0	7	510
06:45	1	173	40	0	214	29	11	18	0	58	26	171	0	0	197	0	7	1	0	8	477
Total	4	655	118	0	777	98	27	39	0	164	64	663	1	0	728	0	13	3	0	16	1685
07:00	2	149	36	0	187	49	9	41	0	99	13	199	0	0	212	2	2	1	0	5	503
07:15	4	190	30	0	224	22	16	24	0	62	21	192	1	0	214	0	1	1	0	2	502
07:30	7	178	17	0	202	26	12	18	0	56	18	189	1	0	208	1	3	2	0	6	472
07:45	6	182	38	0	226	22	13	17	0	52	22	197	0	0	219	0	7	2	0	9	506
Total	19	699	121	0	839	119	50	100	0	269	74	777	2	0	853	3	13	6	0	22	1983
08:00	6	144	20	0	170	8	8	12	1	29	13	151	1	0	165	0	2	1	0	3	367
08:15	1	149	23	0	173	18	8	16	0	42	12	145	2	0	159	2	4	2	0	8	382
08:30	1	158	19	0	178	14	27	23	0	64	15	145	2	0	162	1	7	0	0	8	412
08:45	2	137	25	0	164	25	23	25	0	73	11	148	0	0	159	3	2	2	0	7	403
Total	10	588	87	0	685	65	66	76	1	208	51	589	5	0	645	6	15	5	0	26	1564
11:00	2	143	24	0	169	17	6	16	0	39	19	168	2	0	189	0	2	0	0	2	399
11:15	2	141	24	0	167	25	13	18	0	56	13	133	2	0	148	0	3	0	0	3	374
11:30	2	159	30	0	191	33	15	13	0	61	16	169	1	0	186	0	3	4	0	7	445
11:45	1	137	23	0	161	20	19	19	0	58	18	144	1	0	163	0	5	2	0	7	389
Total	7	580	101	0	688	95	53	66	0	214	66	614	6	0	686	0	13	6	0	19	1607
12:00	6	156	26	0	188	25	12	20	0	57	11	166	0	0	177	3	8	2	0	13	435
12:15	1	140	22	0	163	9	11	15	0	35	18	153	0	0	171	0	8	0	0	8	377
12:30	4	146	19	0	169	23	8	19	0	50	26	172	1	0	199	0	3	2	0	5	423
12:45	5	184	28	0	217	24	9	7	0	40	29	136	1	0	166	1	5	1	0	7	430
Total	16	626	95	0	737	81	40	61	0	182	84	627	2	0	713	4	24	5	0	33	1665
15:00	1	199	35	0	235	74	33	36	0	143	20	217	2	0	239	1	9	2	0	12	629
15:15	3	204	27	0	234	48	28	25	1	102	27	187	3	0	217	1	7	3	0	11	564
15:30	4	270	29	0	303	54	15	22	0	91	24	211	1	0	236	2	6	2	0	10	640
15:45	4	223	29	0	256	53	13	22	0	88	21	206	0	0	227	2	7	6	0	15	586
Total	12	896	120	0	1028	229	89	105	1	424	92	821	6	0	919	6	29	13	0	48	2419
16:00	5	223	22	0	250	34	22	27	0	83	12	239	1	0	252	0	8	1	0	9	594
16:15	7	200	27	0	234	43	13	10	0	66	16	226	2	0	244	1	5	1	0	7	551
16:30	4	258	30	0	292	46	8	20	0	74	14	237	1	0	252	1	6	2	0	9	627
16:45	4	258	46	0	308	57	12	17	0	86	19	235	4	0	258	1	6	5	0	12	664
Total	20	939	125	0	1084	180	55	74	0	309	61	937	8	0	1006	3	25	9	0	37	2436
17:00	5	256	31	0	292	52	18	23	0	93	20	242	0	0	262	0	12	2	0	14	661
17:15	2	249	37	0	288	45	14	16	0	75	25	206	1	0	232	1	12	3	0	16	611
17:30	7	191	29	0	227	38	11	21	0	70	13	177	3	0	193	2	3	1	0	6	496
17:45	3	192	28	0	223	44	14	23	0	81	20	218	0	0	238	1	2	3	0	6	548
Total	17	888	125	0	1030	179	57	83	0	319	78	843	4	0	925	4	29	9	0	42	2316



# MINNESOTA DEPT OF TRANSPORTATION

TRAFFIC COLLECTION - METRO

File Name : TH 61 AT 10TH ST AM NOON PM 2006

Site Code : 00000000

Start Date : 2/7/2006

Page No : 2

Groups Printed- Cars & Trucks

	TH 61 Southbound					10TH ST NOON Westbound					TH 61 Northbound					10TH ST NOON Eastbound					Int. Total
	Right	Thru	Left	Peds	App. Total	Right	Thru	Left	Peds	App. Total	Right	Thru	Left	Peds	App. Total	Right	Thru	Left	Peds	App. Total	
Grand Total	105	5871	892	0	6868	1046	437	604	2	2089	570	5871	34	0	6475	26	161	56	0	243	15675
Apprch %	1.5	85.5	13	0		50.1	20.9	28.9	0.1		8.8	90.7	0.5	0		10.7	66.3	23	0		
Total %	0.7	37.5	5.7	0	43.8	6.7	2.8	3.9	0	13.3	3.6	37.5	0.2	0	41.3	0.2	1	0.4	0	1.6	



# MINNESOTA DEPT OF TRANSPORTATION

TRAFFIC COLLECTION - METRO

File Name : TH 61 AT 10TH ST AM NOON PM 2006

Site Code : 00000000

Start Date : 2/7/2006

Page No : 3

Start Time	TH 61 Southbound					10TH ST NOON Westbound					TH 61 Northbound					10TH ST NOON Eastbound					Int. Total
	Right	Thru	Left	Peds	App. Total	Right	Thru	Left	Peds	App. Total	Right	Thru	Left	Peds	App. Total	Right	Thru	Left	Peds	App. Total	
Peak Hour Analysis From 06:00 to 09:45 - Peak 1 of 1																					
Peak Hour for Entire Intersection Begins at 06:30																					
06:30	2	204	30	0	236	21	9	7	0	37	20	210	0	0	230	0	5	2	0	7	510
06:45	1	173	40	0	214	29	11	18	0	58	26	171	0	0	197	0	7	1	0	8	477
07:00	2	149	36	0	187	49	9	41	0	99	13	199	0	0	212	2	2	1	0	5	503
07:15	4	190	30	0	224	22	16	24	0	62	21	192	1	0	214	0	1	1	0	2	502
Total Volume	9	716	136	0	861	121	45	90	0	256	80	772	1	0	853	2	15	5	0	22	1992
% App. Total	1	83.2	15.8	0		47.3	17.6	35.2	0		9.4	90.5	0.1	0		9.1	68.2	22.7	0		
PHF	.563	.877	.850	.000	.912	.617	.703	.549	.000	.646	.769	.919	.250	.000	.927	.250	.536	.625	.000	.688	.976

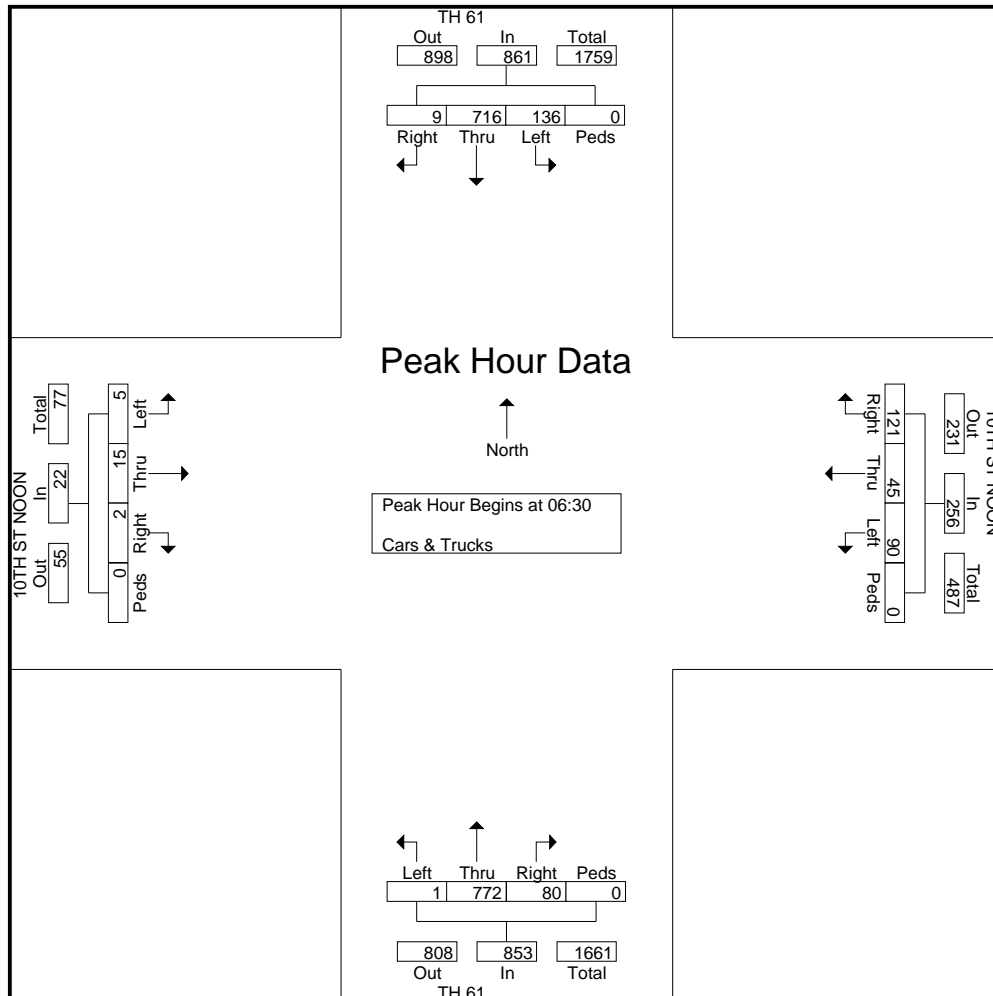



# MINNESOTA DEPT OF TRANSPORTATION

TRAFFIC COLLECTION - METRO

File Name : TH 61 AT 10TH ST AM NOON PM 2006

Site Code : 00000000

Start Date : 2/7/2006

Page No : 4

Start Time	TH 61 Southbound					10TH ST NOON Westbound					TH 61 Northbound					10TH ST NOON Eastbound					Int. Total
	Right	Thru	Left	Peds	App. Total	Right	Thru	Left	Peds	App. Total	Right	Thru	Left	Peds	App. Total	Right	Thru	Left	Peds	App. Total	
12:00	6	156	26	0	188	25	12	20	0	57	11	166	0	0	177	3	8	2	0	13	435
12:15	1	140	22	0	163	9	11	15	0	35	18	153	0	0	171	0	8	0	0	8	377
12:30	4	146	19	0	169	23	8	19	0	50	26	172	1	0	199	0	3	2	0	5	423
12:45	5	184	28	0	217	24	9	7	0	40	29	136	1	0	166	1	5	1	0	7	430
Total Volume	16	626	95	0	737	81	40	61	0	182	84	627	2	0	713	4	24	5	0	33	1665
% App. Total	2.2	84.9	12.9	0		44.5	22	33.5	0		11.8	87.9	0.3	0		12.1	72.7	15.2	0		
PHF	.667	.851	.848	.000	.849	.810	.833	.763	.000	.798	.724	.911	.500	.000	.896	.333	.750	.625	.000	.635	.957

Peak Hour Analysis From 10:00 to 13:45 - Peak 1 of 1

Peak Hour for Entire Intersection Begins at 12:00

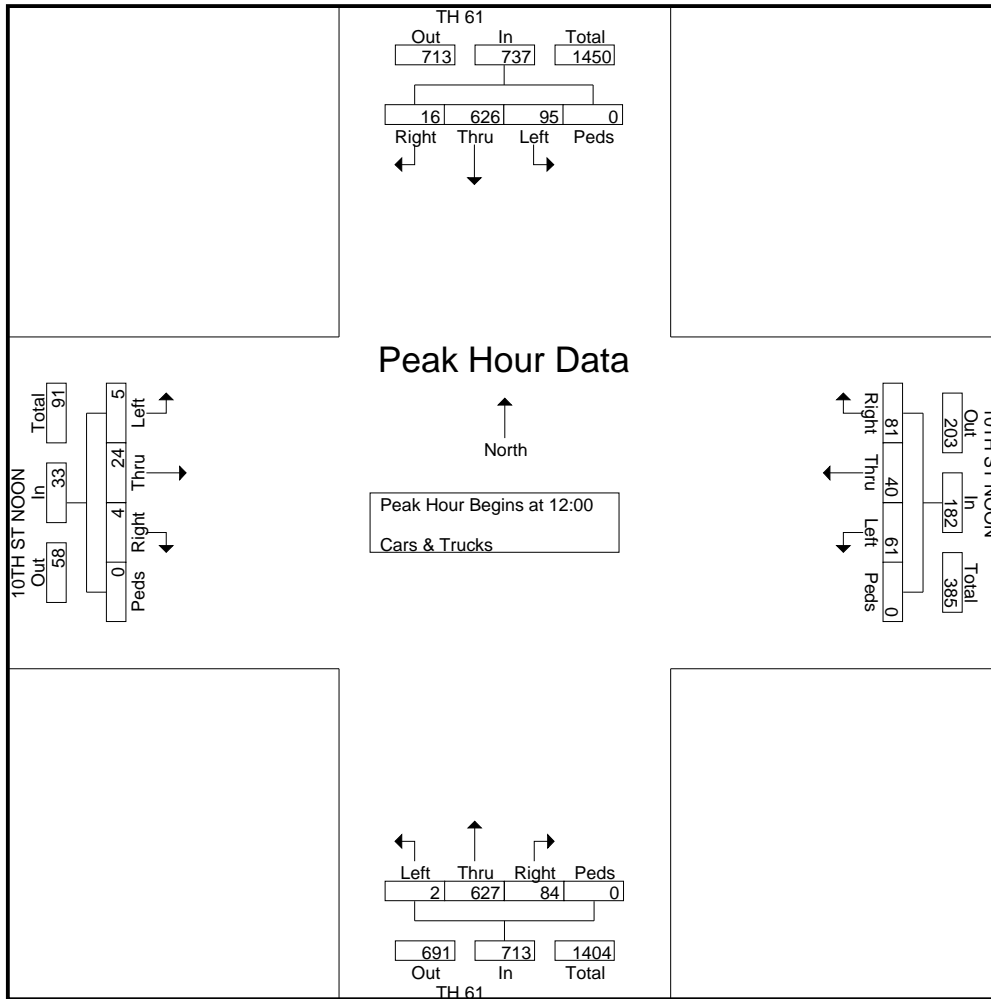



# MINNESOTA DEPT OF TRANSPORTATION

TRAFFIC COLLECTION - METRO

File Name : TH 61 AT 10TH ST AM NOON PM 2006

Site Code : 00000000

Start Date : 2/7/2006

Page No : 5

Start Time	TH 61 Southbound					10TH ST NOON Westbound					TH 61 Northbound					10TH ST NOON Eastbound					Int. Total
	Right	Thru	Left	Peds	App. Total	Right	Thru	Left	Peds	App. Total	Right	Thru	Left	Peds	App. Total	Right	Thru	Left	Peds	App. Total	
16:30	4	<b>258</b>	30	0	292	46	8	20	0	74	14	237	1	0	252	<b>1</b>	6	2	0	9	627
16:45	4	258	<b>46</b>	0	<b>308</b>	<b>57</b>	12	17	0	86	19	235	<b>4</b>	0	258	1	6	<b>5</b>	0	12	<b>664</b>
17:00	<b>5</b>	256	31	0	292	52	<b>18</b>	<b>23</b>	0	<b>93</b>	20	<b>242</b>	0	0	<b>262</b>	0	<b>12</b>	2	0	14	661
17:15	2	249	37	0	288	45	14	16	0	75	<b>25</b>	206	1	0	232	1	12	3	0	<b>16</b>	611
Total Volume	15	1021	144	0	1180	200	52	76	0	328	78	920	6	0	1004	3	36	12	0	51	2563
% App. Total	1.3	86.5	12.2	0		61	15.9	23.2	0		7.8	91.6	0.6	0		5.9	70.6	23.5	0		
PHF	.750	.989	.783	.000	.958	.877	.722	.826	.000	.882	.780	.950	.375	.000	.958	.750	.750	.600	.000	.797	.965

Peak Hour Analysis From 14:00 to 17:45 - Peak 1 of 1  
 Peak Hour for Entire Intersection Begins at 16:30

