

# Associated Consulting Services (ACS)

Saint Paul, MN 55127

-- TRAFFIC DATA --

TH-61 at TH-694 S.Ramp\_2019  
 Ref Pt: 143+00.586  
 Data Prepared By: ACS  
 TURNING MOVEMENT COUNT

File Name : TH-61 at TH-694 S Ramp\_2019  
 Site Code :  
 Start Date : 1/16/2019  
 Page No : 1

Groups Printed- Cars - Trucks

Start Time	TH-61 Southbound				TH-694 S Ramp Westbound				TH-61 Northbound				TH-694 S Ramp Eastbound				Int. Total	
	Left	Thru	Right	Peds	Left	Thru	Right	Peds	Left	Thru	Right	Peds	Left	Thru	Right	Peds		
06:00	24	77	0	0	0	0	0	0	0	0	73	12	0	38	0	46	0	270
06:15	32	108	0	0	0	0	0	0	0	0	89	14	0	50	0	89	0	382
06:30	26	195	0	0	0	0	0	0	0	0	115	9	0	62	0	103	0	510
06:45	50	194	0	0	0	0	0	0	0	0	100	12	0	95	0	171	0	622
Total	132	574	0	0	0	0	0	0	0	0	377	47	0	245	0	409	0	1784
07:00	42	219	0	0	0	0	0	0	0	0	120	16	0	61	2	184	0	644
07:15	50	351	0	0	0	0	0	0	0	0	123	24	0	69	0	281	0	898
07:30	60	379	0	0	0	0	0	0	0	0	169	27	0	70	0	296	0	1001
07:45	48	352	0	0	0	0	0	0	0	0	179	32	0	74	0	287	0	972
Total	200	1301	0	0	0	0	0	0	0	0	591	99	0	274	2	1048	0	3515
08:00	50	277	0	0	0	0	0	0	0	0	178	25	0	73	0	130	0	733
08:15	50	188	0	0	0	0	0	0	0	0	160	18	0	58	0	121	0	595
08:30	34	145	0	0	0	0	0	0	0	0	113	24	0	65	0	101	0	482
08:45	38	162	0	0	0	0	0	0	0	0	180	17	0	61	0	118	0	576
Total	172	772	0	0	0	0	0	0	0	0	631	84	0	257	0	470	0	2386
09:00	32	132	0	0	0	0	0	0	0	0	130	27	0	65	0	103	0	489
09:15	35	154	0	0	0	0	0	0	0	0	133	17	0	63	0	108	0	510
09:30	38	118	0	0	0	0	0	0	0	0	159	25	0	62	0	94	0	496
09:45	34	143	0	0	0	0	0	0	0	0	116	23	0	65	0	115	0	496
Total	139	547	0	0	0	0	0	0	0	0	538	92	0	255	0	420	0	1991
10:00	18	119	0	0	0	0	0	0	0	0	153	20	0	65	0	105	0	480
10:15	41	122	0	0	0	0	0	0	0	0	173	18	0	56	1	97	0	508
10:30	44	132	0	0	0	0	0	0	0	0	182	30	0	72	0	121	0	581
10:45	41	143	0	0	0	0	0	0	0	0	178	27	0	62	0	95	0	546
Total	144	516	0	0	0	0	0	0	0	0	686	95	0	255	1	418	0	2115
11:00	41	146	0	0	0	0	0	0	0	0	221	22	0	69	0	95	0	594
11:15	37	182	0	0	0	0	0	0	0	0	212	19	0	74	1	66	0	591
11:30	37	137	0	0	0	0	0	0	0	0	192	32	0	70	0	106	0	574
11:45	46	149	0	0	0	0	0	0	0	0	234	27	0	69	0	131	1	657
Total	161	614	0	0	0	0	0	0	0	0	859	100	0	282	1	398	1	2416
12:00	34	163	0	0	0	0	0	0	0	0	239	27	0	63	0	100	0	626
12:15	35	159	0	0	0	0	0	0	0	0	210	18	0	62	0	94	0	578
12:30	37	152	0	0	0	0	0	0	0	0	243	39	0	64	1	115	0	651
12:45	45	167	0	0	0	0	0	0	0	0	239	33	0	79	0	146	0	709
Total	151	641	0	0	0	0	0	0	0	0	931	117	0	268	1	455	0	2564
13:00	34	156	0	0	0	0	0	0	0	0	239	29	0	74	0	112	0	644
13:15	44	152	0	0	0	0	0	0	0	0	255	37	0	69	0	117	0	674
13:30	39	157	0	0	0	0	0	0	0	0	264	36	0	72	1	127	0	696
13:45	44	190	0	0	0	0	0	0	0	0	297	34	0	70	1	96	0	732
Total	161	655	0	0	0	0	0	0	0	0	1055	136	0	285	2	452	0	2746
14:00	39	169	0	0	0	0	0	0	0	0	264	31	0	61	0	113	0	677
14:15	37	150	0	0	0	0	0	0	0	0	267	40	0	64	1	122	0	681
14:30	49	161	0	0	0	0	0	0	0	0	275	38	0	75	0	142	0	740

# Associated Consulting Services (ACS)

Saint Paul, MN 55127

-- TRAFFIC DATA --

TH-61 at TH-694 S.Ramp\_2019

File Name : TH-61 at TH-694 S Ramp\_2019

Ref Pt: 143+00.586

Site Code :

Data Prepared By: ACS

Start Date : 1/16/2019

TURNING MOVEMENT COUNT

Page No : 2

Groups Printed- Cars - Trucks

Start Time	TH-61 Southbound				TH-694 S Ramp Westbound				TH-61 Northbound				TH-694 S Ramp Eastbound				Int. Total
	Left	Thru	Right	Peds	Left	Thru	Right	Peds	Left	Thru	Right	Peds	Left	Thru	Right	Peds	
14:45	47	161	0	0	0	0	0	0	0	294	42	0	82	0	134	0	760
Total	172	641	0	0	0	0	0	0	0	1100	151	0	282	1	511	0	2858
15:00	51	197	0	0	0	0	0	0	0	304	34	0	86	0	116	0	788
15:15	55	175	0	0	0	0	0	0	0	340	39	0	97	0	147	0	853
15:30	52	186	0	0	0	0	0	0	0	329	46	0	65	1	139	0	818
15:45	62	208	0	0	0	0	0	0	0	343	51	0	93	1	154	0	912
Total	220	766	0	0	0	0	0	0	0	1316	170	0	341	2	556	0	3371
16:00	66	187	0	0	0	0	0	0	0	392	44	0	78	0	124	0	891
16:15	69	195	0	0	0	0	0	0	0	350	38	0	81	4	150	0	887
16:30	59	192	0	0	0	0	0	0	0	373	46	0	98	0	196	0	964
16:45	52	175	0	0	0	0	0	0	0	380	41	0	110	1	195	0	954
Total	246	749	0	0	0	0	0	0	0	1495	169	0	367	5	665	0	3696
17:00	51	193	0	0	0	0	0	0	0	425	48	0	95	1	181	0	994
17:15	55	157	0	0	0	0	0	0	0	349	37	0	87	0	164	0	849
17:30	50	156	0	0	0	0	0	0	0	331	36	0	69	1	123	0	766
17:45	64	145	0	0	0	0	0	0	0	264	39	0	68	0	116	0	696
Total	220	651	0	0	0	0	0	0	0	1369	160	0	319	2	584	0	3305
Grand Total	2118	8427	0	0	0	0	0	0	0	10948	1420	0	3430	17	6386	1	32747
Apprch %	20.1	79.9	0	0	0	0	0	0	0	88.5	11.5	0	34.9	0.2	64.9	0	
Total %	6.5	25.7	0	0	0	0	0	0	0	33.4	4.3	0	10.5	0.1	19.5	0	
Cars	1972	8228	0	0	0	0	0	0	0	10745	1373	0	3229	15	6264	1	31827
% Cars	93.1	97.6	0	0	0	0	0	0	0	98.1	96.7	0	94.1	88.2	98.1	100	97.2
Trucks	146	199	0	0	0	0	0	0	0	203	47	0	201	2	122	0	920
% Trucks	6.9	2.4	0	0	0	0	0	0	0	1.9	3.3	0	5.9	11.8	1.9	0	2.8

# Associated Consulting Services (ACS)

Saint Paul, MN 55127

-- TRAFFIC DATA --

TH-61 at TH-694 S.Ramp\_2019  
 Ref Pt: 143+00.586  
 Data Prepared By: ACS  
 TURNING MOVEMENT COUNT

File Name : TH-61 at TH-694 S Ramp\_2019  
 Site Code :  
 Start Date : 1/16/2019  
 Page No : 3

Start Time	TH-61 Southbound					TH-694 S Ramp Westbound					TH-61 Northbound					TH-694 S Ramp Eastbound					Int. Total
	Left	Thru	Right	Peds	App. Total	Left	Thru	Right	Peds	App. Total	Left	Thru	Right	Peds	App. Total	Left	Thru	Right	Peds	App. Total	
Peak Hour Analysis From 06:00 to 11:45 - Peak 1 of 1																					
Peak Hour for Entire Intersection Begins at 07:15																					
07:15	50	351	0	0	401	0	0	0	0	0	0	123	24	0	147	69	0	281	0	350	898
07:30	<b>60</b>	<b>379</b>	0	0	<b>439</b>	0	0	0	0	0	0	169	27	0	196	70	0	<b>296</b>	0	<b>366</b>	<b>1001</b>
07:45	48	352	0	0	400	0	0	0	0	0	0	<b>179</b>	<b>32</b>	0	<b>211</b>	<b>74</b>	0	287	0	361	972
08:00	50	277	0	0	327	0	0	0	0	0	0	178	25	0	203	73	0	130	0	203	733
Total Volume	208	1359	0	0	1567	0	0	0	0	0	0	649	108	0	757	286	0	994	0	1280	3604
% App. Total	13.3	86.7	0	0		0	0	0	0		0	85.7	14.3	0		22.3	0	77.7	0		
PHF	.867	.896	.000	.000	.892	.000	.000	.000	.000	.000	.000	.906	.844	.000	.897	.966	.000	.840	.000	.874	.900

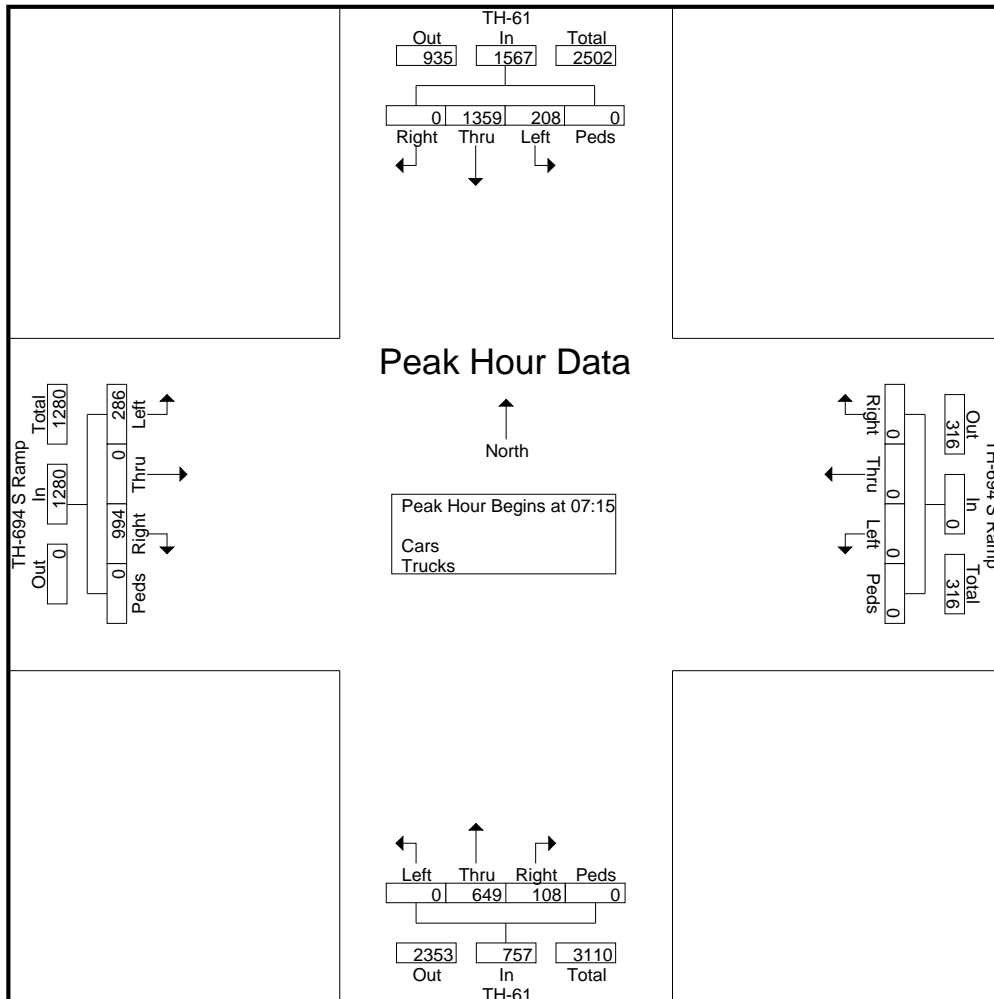

# Associated Consulting Services (ACS)

Saint Paul, MN 55127

-- TRAFFIC DATA --

TH-61 at TH-694 S.Ramp\_2019  
 Ref Pt: 143+00.586  
 Data Prepared By: ACS  
 TURNING MOVEMENT COUNT

File Name : TH-61 at TH-694 S Ramp\_2019  
 Site Code :  
 Start Date : 1/16/2019  
 Page No : 4

Start Time	TH-61 Southbound					TH-694 S Ramp Westbound					TH-61 Northbound					TH-694 S Ramp Eastbound					Int. Total
	Left	Thru	Right	Peds	App. Total	Left	Thru	Right	Peds	App. Total	Left	Thru	Right	Peds	App. Total	Left	Thru	Right	Peds	App. Total	
Peak Hour Analysis From 12:00 to 17:45 - Peak 1 of 1																					
Peak Hour for Entire Intersection Begins at 16:15																					
16:15	<b>69</b>	<b>195</b>	0	0	<b>264</b>	0	0	0	0	0	0	350	38	0	388	81	<b>4</b>	150	0	235	887
16:30	59	192	0	0	251	0	0	0	0	0	0	373	46	0	419	98	0	<b>196</b>	0	294	964
16:45	52	175	0	0	227	0	0	0	0	0	0	380	41	0	421	<b>110</b>	1	195	0	<b>306</b>	954
17:00	51	193	0	0	244	0	0	0	0	0	0	<b>425</b>	<b>48</b>	0	<b>473</b>	95	1	181	0	277	<b>994</b>
Total Volume	231	755	0	0	986	0	0	0	0	0	0	1528	173	0	1701	384	6	722	0	1112	3799
% App. Total	23.4	76.6	0	0		0	0	0	0		0	89.8	10.2	0		34.5	0.5	64.9	0		
PHF	.837	.968	.000	.000	.934	.000	.000	.000	.000	.000	.000	.899	.901	.000	.899	.873	.375	.921	.000	.908	.955

