



# MINNESOTA DEPT OF TRANSPORTATION

## TRAFFIC DATA COLLECTION - METRO

TH-61 AT 8TH AVE FOREST LAKE  
 Ref. Pt. 160.00.390  
 JAMAR# 632 DR  
 TURN MOVEMENT COUNT

File Name : TH 61 AT 8TH AVE 2008  
 Site Code : 00000000  
 Start Date : 7/17/2008  
 Page No : 1

### Groups Printed- Unshifted

Start Time	TH 61 Southbound				8TH AVE Westbound				TH 61 Northbound				8TH AVE Eastbound				Int. Total	
	Left	Thru	Right	Peds	Left	Thru	Right	Peds	Left	Thru	Right	Peds	Left	Thru	Right	Peds		
06:00	3	61	0	0	2	0	2	0	0	17	1	0	0	0	0	0	0	86
06:15	2	63	0	0	2	0	3	0	3	28	0	0	1	0	0	0	0	102
06:30	3	71	1	0	6	1	3	0	0	46	0	0	0	0	0	0	0	131
06:45	5	70	0	0	6	0	6	0	0	48	0	0	0	2	0	0	0	137
Total	13	265	1	0	16	1	14	0	3	139	1	0	1	2	0	0	0	456
07:00	3	78	1	0	2	4	3	0	3	61	1	0	0	2	0	0	0	158
07:15	6	79	0	0	4	3	5	0	1	67	1	0	2	1	2	0	0	171
07:30	8	94	2	0	4	6	6	0	4	63	1	0	2	1	0	0	0	191
07:45	2	93	1	0	4	2	7	0	2	91	1	0	0	0	1	0	0	204
Total	19	344	4	0	14	15	21	0	10	282	4	0	4	4	3	0	0	724
08:00	9	96	1	0	3	3	8	0	1	101	0	0	1	1	3	0	0	227
08:15	7	90	1	0	4	4	9	0	4	84	3	0	2	2	1	0	0	211
08:30	9	73	0	0	5	1	10	0	1	84	4	0	0	0	2	0	0	189
08:45	22	104	5	0	6	0	7	0	3	90	4	0	3	2	1	0	0	247
Total	47	363	7	0	18	8	34	0	9	359	11	0	6	5	7	0	0	874
*** BREAK ***																		
15:00	34	110	8	0	10	5	7	0	24	129	8	0	7	8	12	1	0	363
15:15	21	103	6	0	13	6	18	0	18	139	5	0	18	7	6	0	0	360
15:30	23	133	10	0	1	12	16	0	20	164	6	0	11	6	9	0	0	411
15:45	24	121	9	0	5	5	9	0	18	158	5	0	11	12	15	0	0	392
Total	102	467	33	0	29	28	50	0	80	590	24	0	47	33	42	1	0	1526
16:00	24	152	9	0	5	6	15	0	26	150	9	0	14	3	4	0	0	417
16:15	18	126	6	0	12	3	13	0	27	171	8	0	12	9	11	0	0	416
16:30	27	129	15	0	12	13	18	0	22	179	12	0	20	6	16	0	0	469
16:45	21	146	5	0	7	8	27	0	18	170	12	0	11	8	8	0	0	441
Total	90	553	35	0	36	30	73	0	93	670	41	0	57	26	39	0	0	1743
17:00	22	138	7	0	7	10	12	0	19	190	8	0	14	6	9	0	0	442
17:15	31	163	7	0	7	10	19	0	24	171	6	0	17	6	5	0	0	466
17:30	17	145	14	0	4	7	16	0	8	159	10	0	12	3	9	0	0	404
17:45	15	146	8	0	9	8	11	0	13	178	7	0	15	3	9	0	0	422
Total	85	592	36	0	27	35	58	0	64	698	31	0	58	18	32	0	0	1734
Grand Total	356	2584	116	0	140	117	250	0	259	2738	112	0	173	88	123	1	0	7057
Apprch %	11.6	84.6	3.8	0	27.6	23.1	49.3	0	8.3	88.1	3.6	0	44.9	22.9	31.9	0.3	0	
Total %	5	36.6	1.6	0	2	1.7	3.5	0	3.7	38.8	1.6	0	2.5	1.2	1.7	0	0	



# MINNESOTA DEPT OF TRANSPORTATION

## TRAFFIC DATA COLLECTION - METRO

TH-61 AT 8TH AVE FOREST LAKE  
 Ref. Pt. 160.00.390  
 JAMAR# 632 DR  
 TURN MOVEMENT COUNT

File Name : TH 61 AT 8TH AVE 2008  
 Site Code : 00000000  
 Start Date : 7/17/2008  
 Page No : 2

Start Time	TH 61 Southbound					8TH AVE Westbound					TH 61 Northbound					8TH AVE Eastbound					Int. Total
	Left	Thru	Right	Peds	App. Total	Left	Thru	Right	Peds	App. Total	Left	Thru	Right	Peds	App. Total	Left	Thru	Right	Peds	App. Total	
<b>Peak Hour Analysis From 06:00 to 08:45 - Peak 1 of 1</b>																					
Peak Hour for Entire Intersection Begins at 08:00																					
08:00	9	96	1	0	106	3	3	8	0	14	1	101	0	0	102	1	1	3	0	5	227
08:15	7	90	1	0	98	4	4	9	0	17	4	84	3	0	91	2	2	1	0	5	211
08:30	9	73	0	0	82	5	1	10	0	16	1	84	4	0	89	0	0	2	0	2	189
08:45	22	104	5	0	131	6	0	7	0	13	3	90	4	0	97	3	2	1	0	6	247
Total Volume	47	363	7	0	417	18	8	34	0	60	9	359	11	0	379	6	5	7	0	18	874
% App. Total																					
PHF	.534	.873	.350	.000	.796	.750	.500	.850	.000	.882	.563	.889	.688	.000	.929	.500	.625	.583	.000	.750	.885

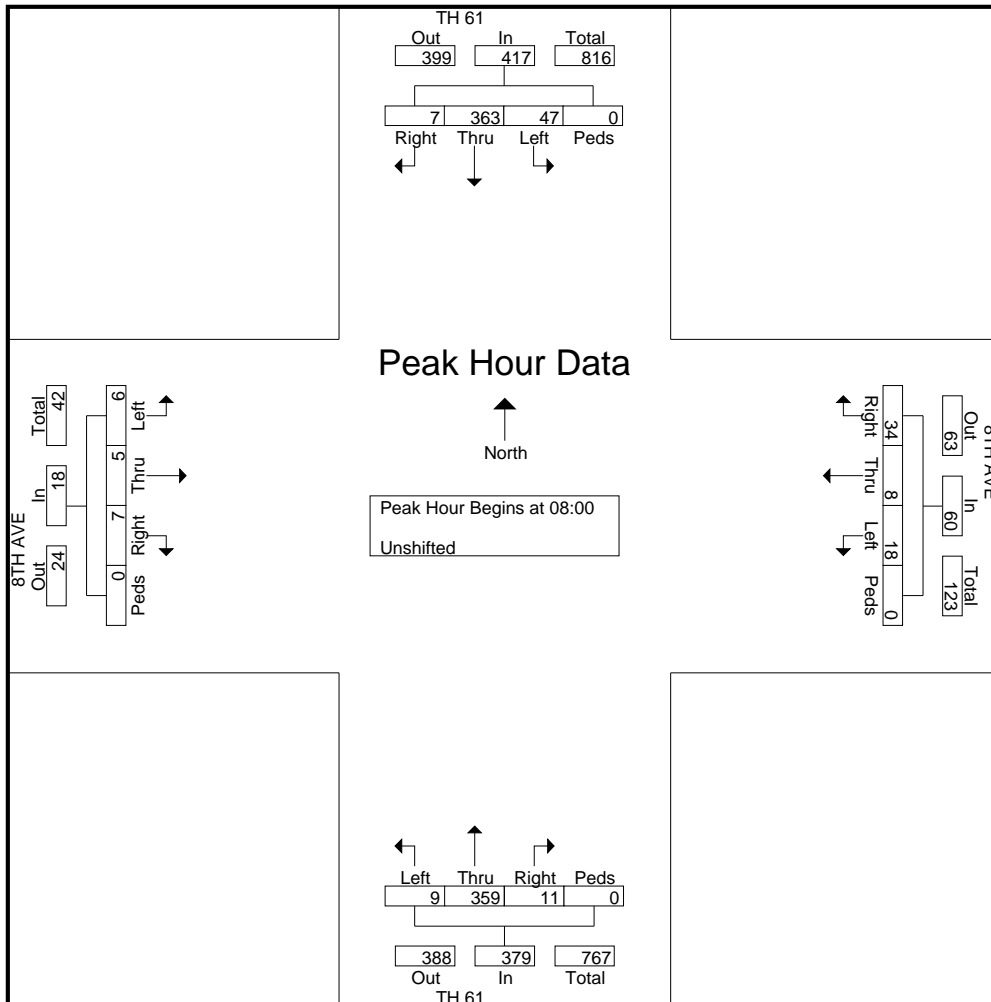



# MINNESOTA DEPT OF TRANSPORTATION

## TRAFFIC DATA COLLECTION - METRO

TH-61 AT 8TH AVE FOREST LAKE  
 Ref. Pt. 160.00.390  
 JAMAR# 632 DR  
 TURN MOVEMENT COUNT

File Name : TH 61 AT 8TH AVE 2008  
 Site Code : 00000000  
 Start Date : 7/17/2008  
 Page No : 3

Start Time	TH 61 Southbound					8TH AVE Westbound					TH 61 Northbound					8TH AVE Eastbound					Int. Total
	Left	Thru	Right	Peds	App. Total	Left	Thru	Right	Peds	App. Total	Left	Thru	Right	Peds	App. Total	Left	Thru	Right	Peds	App. Total	
Peak Hour Analysis From 15:00 to 17:45 - Peak 1 of 1																					
Peak Hour for Entire Intersection Begins at 16:30																					
16:30	27	129	15	0	171	12	13	18	0	43	22	179	12	0	213	20	6	16	0	42	469
16:45	21	146	5	0	172	7	8	27	0	42	18	170	12	0	200	11	8	8	0	27	441
17:00	22	138	7	0	167	7	10	12	0	29	19	190	8	0	217	14	6	9	0	29	442
17:15	31	163	7	0	201	7	10	19	0	36	24	171	6	0	201	17	6	5	0	28	466
Total Volume	101	576	34	0	711	33	41	76	0	150	83	710	38	0	831	62	26	38	0	126	1818
% App. Total																					
PHF	.815	.883	.567	.000	.884	.688	.788	.704	.000	.872	.865	.934	.792	.000	.957	.775	.813	.594	.000	.750	.969

