

# Alliant Engineering Inc Minneapolis, MN 55415

TH-65 at 89th Ave NE BLAINE  
Ref.Pt.: 010.896  
data by Alliant Engineering Inc  
TURN MOVEMENT COUNT

File Name : TH-65 at 89th Ave NE 2009  
Site Code : 00000010  
Start Date : 1/8/2009  
Page No : 1

### Groups Printed- Unshifted

Start Time	TH-65 Southbound				89th Ave NE Westbound				TH-65 Northbound				89th Ave NE Eastbound				Int. Total
	Left	Thru	Right	Peds	Left	Thru	Right	Peds	Left	Thru	Right	Peds	Left	Thru	Right	Peds	
06:00	0	414	8	0	0	0	4	0	1	55	1	0	6	0	10	0	499
06:15	2	383	10	0	0	0	3	0	3	63	0	0	13	1	14	1	493
06:30	1	475	17	0	0	0	2	1	4	56	0	0	9	2	25	0	592
06:45	2	499	18	1	0	1	1	0	4	99	0	0	9	2	17	0	653
Total	5	1771	53	1	0	1	10	1	12	273	1	0	37	5	66	1	2237
07:00	2	520	19	1	1	0	0	0	7	115	1	0	10	3	16	0	695
07:15	6	469	45	1	1	5	0	0	15	123	0	0	11	2	19	0	697
07:30	1	473	50	1	0	7	3	0	14	137	1	1	12	5	21	0	726
07:45	2	484	65	0	0	2	2	0	12	152	0	0	11	5	23	0	758
Total	11	1946	179	3	2	14	5	0	48	527	2	1	44	15	79	0	2876
08:00	3	368	53	0	0	2	4	0	19	133	0	0	21	3	15	0	621
08:15	3	303	45	0	0	4	2	0	20	106	0	0	29	2	13	0	527
08:30	2	304	32	0	0	2	0	0	17	139	1	0	16	1	17	0	531
08:45	1	266	72	0	0	1	0	0	28	105	0	0	32	3	12	0	520
Total	9	1241	202	0	0	9	6	0	84	483	1	0	98	9	57	0	2199
09:00	6	250	50	0	1	2	1	0	7	127	0	0	28	3	25	1	501
09:15	7	243	27	0	0	1	3	0	14	129	0	0	37	0	10	0	471
*** BREAK ***																	
Total	13	493	77	0	1	3	4	0	21	256	0	0	65	3	35	1	972
*** BREAK ***																	
10:30	6	205	41	0	0	0	1	0	12	167	0	0	27	0	21	0	480
10:45	2	168	37	0	0	6	1	0	6	185	0	0	34	0	14	0	453
Total	8	373	78	0	0	6	2	0	18	352	0	0	61	0	35	0	933
11:00	6	183	36	0	0	1	2	0	13	222	1	0	40	6	15	0	525
11:15	5	236	31	1	0	0	1	0	19	219	2	0	40	2	16	0	572
11:30	5	214	28	0	0	1	5	0	9	230	0	0	41	2	13	0	548
11:45	5	231	35	1	0	2	0	0	20	225	0	0	45	5	16	0	585
Total	21	864	130	2	0	4	8	0	61	896	3	0	166	15	60	0	2230
12:00	4	206	35	0	0	3	3	0	12	219	0	0	68	3	17	0	570
12:15	6	205	40	0	0	1	2	0	21	225	0	0	53	3	19	0	575
12:30	8	215	41	0	0	4	3	0	12	231	1	2	49	4	11	0	581
12:45	2	216	52	0	0	1	1	0	20	200	1	0	46	3	14	0	556
Total	20	842	168	0	0	9	9	0	65	875	2	2	216	13	61	0	2282
13:00	1	203	30	0	1	4	2	0	10	231	0	0	57	2	19	0	560
13:15	8	200	45	2	1	4	4	0	15	215	0	0	35	3	12	0	544
*** BREAK ***																	
Total	9	403	75	2	2	8	6	0	25	446	0	0	92	5	31	0	1104
*** BREAK ***																	
14:30	6	240	37	0	0	0	1	0	24	398	0	0	41	5	12	0	764
14:45	8	239	45	0	0	4	3	0	24	378	0	0	58	6	27	0	792
Total	14	479	82	0	0	4	4	0	48	776	0	0	99	11	39	0	1556
15:00	8	210	32	0	1	1	2	0	25	417	0	0	62	11	31	0	800
15:15	5	222	46	0	1	8	1	0	26	467	0	0	49	1	21	0	847
15:30	3	229	58	0	0	5	3	0	31	481	0	0	49	8	27	0	894
15:45	8	183	61	0	0	3	0	0	28	491	0	0	76	2	30	1	883
Total	24	844	197	0	2	17	6	0	110	1856	0	0	236	22	109	1	3424

# Alliant Engineering Inc Minneapolis, MN 55415

TH-65 at 89th Ave NE BLAINE  
 Ref.Pt.: 010.896  
 data by Alliant Engineering Inc  
 TURN MOVEMENT COUNT

File Name : TH-65 at 89th Ave NE 2009  
 Site Code : 00000010  
 Start Date : 1/8/2009  
 Page No : 2

**Groups Printed- Unshifted**

Start Time	TH-65 Southbound				89th Ave NE Westbound				TH-65 Northbound				89th Ave NE Eastbound				Int. Total
	Left	Thru	Right	Peds	Left	Thru	Right	Peds	Left	Thru	Right	Peds	Left	Thru	Right	Peds	
16:00	9	191	49	0	1	8	4	0	17	440	0	0	80	7	41	0	847
16:15	4	185	33	0	1	4	2	1	13	519	1	0	71	3	27	0	864
16:30	4	237	22	0	2	2	7	0	18	465	2	0	67	3	30	0	859
16:45	3	231	49	0	0	3	1	0	16	491	0	0	54	7	15	0	870
Total	20	844	153	0	4	17	14	1	64	1915	3	0	272	20	113	0	3440
17:00	7	199	50	0	0	4	2	0	28	543	0	0	47	5	17	0	902
17:15	11	201	48	0	0	8	4	0	16	506	0	0	45	7	17	0	863
17:30	9	178	41	0	0	5	4	1	21	451	0	0	53	6	23	0	792
17:45	2	197	37	0	0	1	2	0	10	418	0	0	47	4	12	0	730
Total	29	775	176	0	0	18	12	1	75	1918	0	0	192	22	69	0	3287
Grand Total	183	10875	1570	8	11	110	86	3	631	10573	12	3	1578	140	754	3	26540
Apprch %	1.4	86.1	12.4	0.1	5.2	52.4	41	1.4	5.6	94.2	0.1	0	63.8	5.7	30.5	0.1	
Total %	0.7	41	5.9	0	0	0.4	0.3	0	2.4	39.8	0	0	5.9	0.5	2.8	0	

# Alliant Engineering Inc Minneapolis, MN 55415

TH-65 at 89th Ave NE BLAINE  
 Ref.Pt.: 010.896  
 data by Alliant Engineering Inc  
 TURN MOVEMENT COUNT

File Name : TH-65 at 89th Ave NE 2009  
 Site Code : 00000010  
 Start Date : 1/8/2009  
 Page No : 3

Start Time	TH-65 Southbound					89th Ave NE Westbound					TH-65 Northbound					89th Ave NE Eastbound					Int. Total
	Left	Thru	Right	Peds	App. Total	Left	Thru	Right	Peds	App. Total	Left	Thru	Right	Peds	App. Total	Left	Thru	Right	Peds	App. Total	
Peak Hour Analysis From 06:00 to 08:45 - Peak 1 of 1																					
Peak Hour for Entire Intersection Begins at 07:00																					
07:00	2	520	19	1	542	1	0	0	0	1	7	115	1	0	123	10	3	16	0	29	695
07:15	6	469	45	1	521	1	5	0	0	6	15	123	0	0	138	11	2	19	0	32	697
07:30	1	473	50	1	525	0	7	3	0	10	14	137	1	1	153	12	5	21	0	38	726
07:45	2	484	65	0	551	0	2	2	0	4	12	152	0	0	164	11	5	23	0	39	758
Total Volume	11	1946	179	3	2139	2	14	5	0	21	48	527	2	1	578	44	15	79	0	138	2876
% App. Total	0.5	91	8.4	0.1		9.5	66.7	23.8	0		8.3	91.2	0.3	0.2		31.9	10.9	57.2	0		
PHF	.458	.936	.688	.750	.971	.500	.500	.417	.000	.525	.800	.867	.500	.250	.881	.917	.750	.859	.000	.885	.949

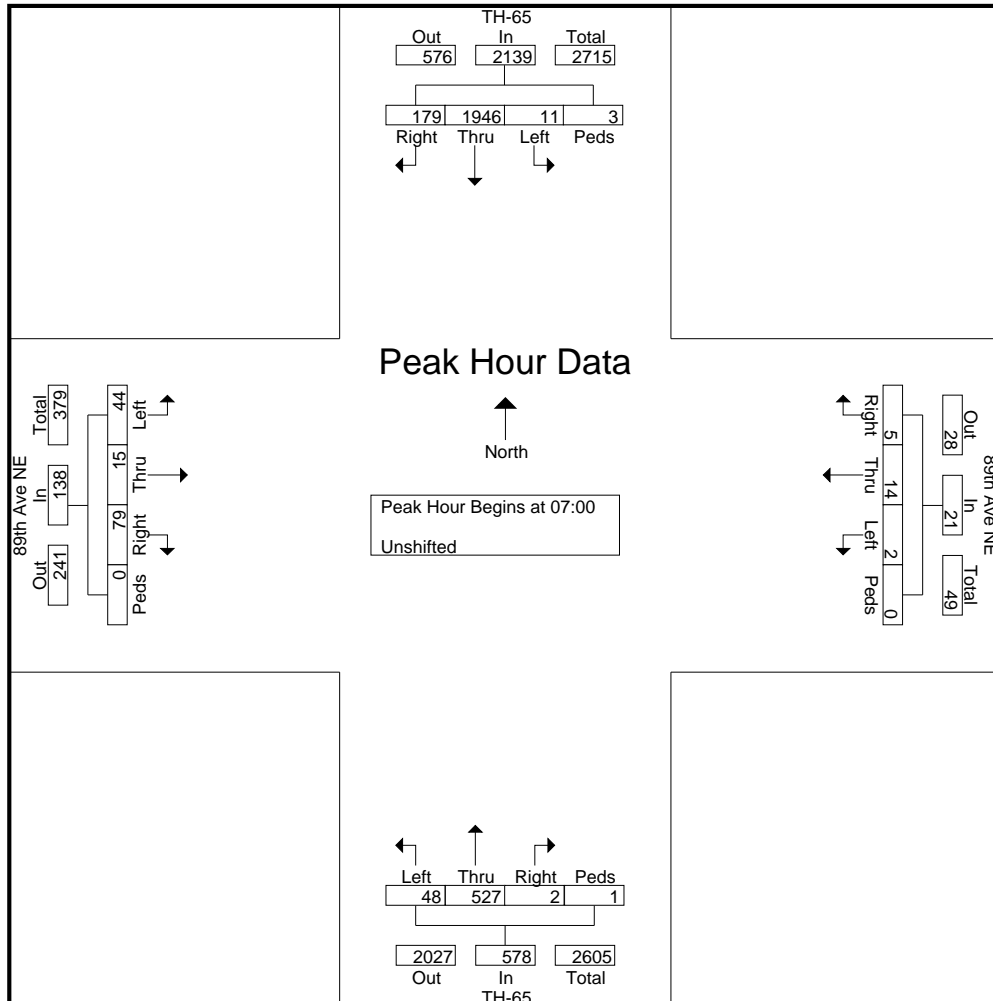

# Alliant Engineering Inc Minneapolis, MN 55415

TH-65 at 89th Ave NE BLAINE  
 Ref.Pt.: 010.896  
 data by Alliant Engineering Inc  
 TURN MOVEMENT COUNT

File Name : TH-65 at 89th Ave NE 2009  
 Site Code : 00000010  
 Start Date : 1/8/2009  
 Page No : 4

Start Time	TH-65 Southbound					89th Ave NE Westbound					TH-65 Northbound					89th Ave NE Eastbound					Int. Total
	Left	Thru	Right	Peds	App. Total	Left	Thru	Right	Peds	App. Total	Left	Thru	Right	Peds	App. Total	Left	Thru	Right	Peds	App. Total	
Peak Hour Analysis From 15:00 to 17:45 - Peak 1 of 1																					
Peak Hour for Entire Intersection Begins at 16:15																					
16:15	4	185	33	0	222	1	4	2	1	8	13	519	1	0	533	71	3	27	0	101	864
16:30	4	237	22	0	263	2	2	7	0	11	18	465	2	0	485	67	3	30	0	100	859
16:45	3	231	49	0	283	0	3	1	0	4	16	491	0	0	507	54	7	15	0	76	870
17:00	7	199	50	0	256	0	4	2	0	6	28	543	0	0	571	47	5	17	0	69	902
Total Volume	18	852	154	0	1024	3	13	12	1	29	75	2018	3	0	2096	239	18	89	0	346	3495
% App. Total	1.8	83.2	15	0		10.3	44.8	41.4	3.4		3.6	96.3	0.1	0		69.1	5.2	25.7	0		
PHF	.643	.899	.770	.000	.905	.375	.813	.429	.250	.659	.670	.929	.375	.000	.918	.842	.643	.742	.000	.856	.969

