

# Alliant Engineering Inc Minneapolis, MN 55415

TH-65 at 109th Ave NE /CSAH-12  
Ref.Pt.: 013.434 BLAINE  
data collected by: Alliant Engineering  
TURN MOVEMENT COUNT

File Name : TH-65 at 109th Ave NE 2009  
Site Code : 00000016  
Start Date : 1/13/2009  
Page No : 1

### Groups Printed- Unshifted

Start Time	TH-65 Southbound				109th Ave NE Westbound				TH-65 Northbound				109th Ave NE Eastbound				Int. Total
	Left	Thru	Right	Peds	Left	Thru	Right	Peds	Left	Thru	Right	Peds	Left	Thru	Right	Peds	
06:00	15	396	2	0	37	12	1	0	2	56	13	0	3	31	26	0	594
06:15	19	351	10	0	70	26	5	0	6	67	7	0	4	34	23	0	622
06:30	14	362	5	0	49	20	11	0	6	62	11	0	6	58	43	0	647
06:45	18	250	10	0	58	43	13	0	10	72	8	0	10	60	31	0	583
Total	66	1359	27	0	214	101	30	0	24	257	39	0	23	183	123	0	2446
07:00	24	271	6	0	62	64	14	0	7	91	8	0	7	58	29	0	641
07:15	24	215	6	0	71	58	8	0	9	97	3	0	12	77	42	0	622
07:30	24	190	5	0	88	97	10	0	8	105	9	0	10	71	25	0	642
07:45	23	214	7	0	99	85	6	0	18	129	13	0	16	70	28	0	708
Total	95	890	24	0	320	304	38	0	42	422	33	0	45	276	124	0	2613
08:00	35	217	12	0	71	65	5	0	18	102	17	0	7	83	40	0	672
08:15	47	203	11	0	73	57	9	0	21	88	20	0	15	72	40	0	656
08:30	45	238	13	0	42	72	11	0	26	106	12	0	11	48	33	0	657
08:45	47	244	11	0	45	41	9	0	18	117	15	0	16	65	37	0	665
Total	174	902	47	0	231	235	34	0	83	413	64	0	49	268	150	0	2650
09:00	44	216	21	0	49	33	14	0	29	120	19	0	10	76	37	0	668
09:15	86	281	13	0	48	36	15	0	17	100	23	0	20	62	35	0	736
*** BREAK ***																	
Total	130	497	34	0	97	69	29	0	46	220	42	0	30	138	72	0	1404
*** BREAK ***																	
10:30	24	162	16	0	36	31	19	0	20	131	11	0	11	37	25	0	523
10:45	26	172	13	0	19	34	20	0	18	147	27	0	12	34	28	0	550
Total	50	334	29	0	55	65	39	0	38	278	38	0	23	71	53	0	1073
11:00	37	134	14	0	30	41	10	0	18	153	21	0	11	36	15	0	520
11:15	33	174	13	0	26	25	14	0	25	143	25	1	14	47	18	0	558
11:30	39	189	10	0	36	44	29	0	20	139	31	0	13	41	19	0	610
11:45	33	167	16	0	25	41	28	0	23	163	36	0	15	49	16	0	612
Total	142	664	53	0	117	151	81	0	86	598	113	1	53	173	68	0	2300
12:00	41	206	16	0	34	56	22	0	27	140	32	0	14	48	20	0	656
12:15	30	194	8	0	33	34	26	0	41	166	39	0	21	43	25	0	660
12:30	36	193	17	0	38	48	15	0	34	172	36	1	13	31	23	0	657
12:45	35	182	25	0	27	31	28	1	43	189	27	0	15	48	23	0	674
Total	142	775	66	0	132	169	91	1	145	667	134	1	63	170	91	0	2647
13:00	51	179	17	0	38	52	28	0	23	159	30	0	16	38	34	0	665
13:15	39	185	9	0	24	44	26	0	35	144	23	0	9	59	25	0	622
*** BREAK ***																	
Total	90	364	26	0	62	96	54	0	58	303	53	0	25	97	59	0	1287
*** BREAK ***																	
14:30	35	206	11	0	32	46	32	0	33	295	26	0	11	54	20	0	801
14:45	27	187	19	0	25	46	26	0	38	357	38	0	30	75	24	0	892
Total	62	393	30	0	57	92	58	0	71	652	64	0	41	129	44	0	1693
15:00	25	177	18	0	23	68	43	0	55	331	43	0	23	35	28	0	869
15:15	27	196	13	0	28	64	34	0	42	395	43	5	34	58	25	0	964
15:30	33	186	14	0	27	75	49	0	57	358	33	1	33	72	26	0	964
15:45	34	167	19	0	37	74	54	0	53	404	26	0	43	70	33	0	1014
Total	119	726	64	0	115	281	180	0	207	1488	145	6	133	235	112	0	3811

# Alliant Engineering Inc

## Minneapolis, MN 55415

TH-65 at 109th Ave NE /CSAH-12  
 Ref.Pt.: 013.434 BLAINE  
 data collected by: Alliant Engineering  
 TURN MOVEMENT COUNT

File Name : TH-65 at 109th Ave NE 2009  
 Site Code : 00000016  
 Start Date : 1/13/2009  
 Page No : 2

**Groups Printed- Unshifted**

Start Time	TH-65 Southbound				109th Ave NE Westbound				TH-65 Northbound				109th Ave NE Eastbound				Int. Total
	Left	Thru	Right	Peds	Left	Thru	Right	Peds	Left	Thru	Right	Peds	Left	Thru	Right	Peds	
16:00	42	160	12	0	34	93	49	0	50	402	35	0	41	79	27	0	1024
16:15	53	188	13	0	40	90	57	0	74	404	27	0	25	72	29	0	1072
16:30	36	201	6	0	50	102	60	0	81	419	44	0	44	77	38	0	1158
16:45	42	218	10	0	50	95	63	0	73	379	34	0	34	90	35	0	1123
Total	173	767	41	0	174	380	229	0	278	1604	140	0	144	318	129	0	4377
17:00	42	254	7	0	34	95	63	0	50	383	34	0	45	108	32	0	1147
17:15	31	233	8	0	32	85	73	8	54	380	11	0	39	105	25	0	1084
17:30	43	235	14	0	45	95	38	1	43	435	46	2	42	85	25	0	1149
17:45	35	199	9	0	35	96	51	2	56	385	46	1	30	81	29	0	1055
Total	151	921	38	0	146	371	225	11	203	1583	137	3	156	379	111	0	4435
Grand Total	1394	8592	479	0	1720	2314	1088	12	1281	8485	1002	11	785	2437	1136	0	30736
Apprch %	13.3	82.1	4.6	0	33.5	45.1	21.2	0.2	11.9	78.7	9.3	0.1	18	55.9	26.1	0	
Total %	4.5	28	1.6	0	5.6	7.5	3.5	0	4.2	27.6	3.3	0	2.6	7.9	3.7	0	

# Alliant Engineering Inc Minneapolis, MN 55415

TH-65 at 109th Ave NE /CSAH-12  
 Ref.Pt.: 013.434 BLAINE  
 data collected by: Alliant Engineering  
 TURN MOVEMENT COUNT

File Name : TH-65 at 109th Ave NE 2009  
 Site Code : 00000016  
 Start Date : 1/13/2009  
 Page No : 3

Start Time	TH-65 Southbound					109th Ave NE Westbound					TH-65 Northbound					109th Ave NE Eastbound					Int. Total
	Left	Thru	Right	Peds	App. Total	Left	Thru	Right	Peds	App. Total	Left	Thru	Right	Peds	App. Total	Left	Thru	Right	Peds	App. Total	
Peak Hour Analysis From 06:00 to 09:00 - Peak 1 of 1																					
Peak Hour for Entire Intersection Begins at 07:45																					
07:45	23	214	7	0	244	99	85	6	0	190	18	129	13	0	160	16	70	28	0	114	708
08:00	35	217	12	0	264	71	65	5	0	141	18	102	17	0	137	7	83	40	0	130	672
08:15	47	203	11	0	261	73	57	9	0	139	21	88	20	0	129	15	72	40	0	127	656
08:30	45	238	13	0	296	42	72	11	0	125	26	106	12	0	144	11	48	33	0	92	657
Total Volume	150	872	43	0	1065	285	279	31	0	595	83	425	62	0	570	49	273	141	0	463	2693
% App. Total	14.1	81.9	4	0		47.9	46.9	5.2	0		14.6	74.6	10.9	0		10.6	59	30.5	0		
PHF	.798	.916	.827	.000	.899	.720	.821	.705	.000	.783	.798	.824	.775	.000	.891	.766	.822	.881	.000	.890	.951

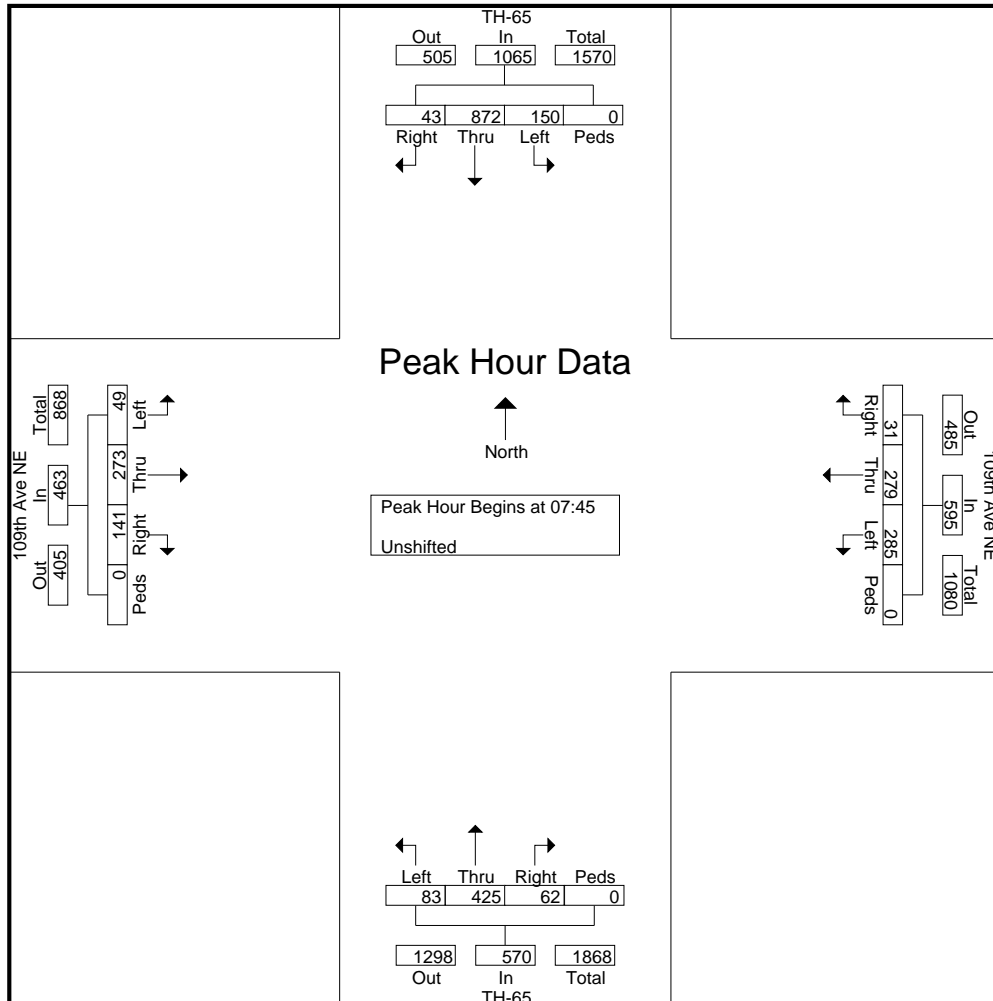

# Alliant Engineering Inc Minneapolis, MN 55415

TH-65 at 109th Ave NE /CSAH-12  
 Ref.Pt.: 013.434 BLAINE  
 data collected by: Alliant Engineering  
 TURN MOVEMENT COUNT

File Name : TH-65 at 109th Ave NE 2009  
 Site Code : 00000016  
 Start Date : 1/13/2009  
 Page No : 4

Start Time	TH-65 Southbound					109th Ave NE Westbound					TH-65 Northbound					109th Ave NE Eastbound					Int. Total
	Left	Thru	Right	Peds	App. Total	Left	Thru	Right	Peds	App. Total	Left	Thru	Right	Peds	App. Total	Left	Thru	Right	Peds	App. Total	
Peak Hour Analysis From 15:00 to 17:45 - Peak 1 of 1																					
Peak Hour for Entire Intersection Begins at 16:30																					
16:30	36	201	6	0	243	50	102	60	0	212	81	419	44	0	544	44	77	38	0	159	1158
16:45	42	218	10	0	270	50	95	63	0	208	73	379	34	0	486	34	90	35	0	159	1123
17:00	42	254	7	0	303	34	95	63	0	192	50	383	34	0	467	45	108	32	0	185	1147
17:15	31	233	8	0	272	32	85	73	8	198	54	380	11	0	445	39	105	25	0	169	1084
Total Volume	151	906	31	0	1088	166	377	259	8	810	258	1561	123	0	1942	162	380	130	0	672	4512
% App. Total	13.9	83.3	2.8	0		20.5	46.5	32	1		13.3	80.4	6.3	0		24.1	56.5	19.3	0		
PHF	.899	.892	.775	.000	.898	.830	.924	.887	.250	.955	.796	.931	.699	.000	.892	.900	.880	.855	.000	.908	.974

