

# Alliant Engineering Inc Minneapolis, MN 55415

TH-65 at Bunker Lake Blvd NE  
Ref.Pt.: 016.928 HAM LAKE  
data by Alliant Engineering Inc  
TURN MOVEMENT COUNT

File Name : TH-65 at Bunker Lake Blvd NE 2009  
Site Code : 00000018  
Start Date : 1/28/2009  
Page No : 1

**Groups Printed- Unshifted**

Start Time	TH-65 Southbound				Bunker Lake Blvd NE Westbound				TH-65 Northbound				Bunker Lake Blvd NE Eastbound				Int. Total
	Left	Thru	Right	Peds	Left	Thru	Right	Peds	Left	Thru	Right	Peds	Left	Thru	Right	Peds	
06:00	5	419	16	0	11	17	1	0	6	26	2	0	3	12	22	0	540
06:15	8	473	30	0	7	11	3	0	7	46	6	0	10	13	29	0	643
06:30	9	448	34	0	16	20	6	0	11	55	4	0	5	23	30	0	661
06:45	16	399	19	0	9	21	8	0	22	66	4	0	15	37	27	0	643
Total	38	1739	99	0	43	69	18	0	46	193	16	0	33	85	108	0	2487
07:00	12	420	28	0	12	44	3	0	15	69	5	0	6	39	44	0	697
07:15	0	444	45	1	19	67	3	0	23	83	7	0	10	31	51	0	784
07:30	16	420	60	0	14	59	9	0	28	109	4	0	14	49	34	0	816
07:45	5	376	60	0	27	80	6	0	31	94	8	0	20	41	36	0	784
Total	33	1660	193	1	72	250	21	0	97	355	24	0	50	160	165	0	3081
08:00	5	308	33	0	19	28	3	0	19	85	9	0	17	24	22	0	572
08:15	6	295	25	0	8	22	7	0	23	109	9	0	8	33	46	0	591
08:30	7	258	14	0	14	36	9	0	19	61	10	0	14	21	48	0	511
08:45	7	250	18	0	13	14	6	0	32	100	9	0	16	11	46	0	522
Total	25	1111	90	0	54	100	25	0	93	355	37	0	55	89	162	0	2196
09:00	4	226	20	0	12	21	7	0	23	97	13	0	8	7	21	0	459
09:15	3	213	17	0	15	32	10	0	13	90	8	0	15	18	32	0	466
*** BREAK ***																	
Total	7	439	37	0	27	53	17	0	36	187	21	0	23	25	53	0	925
*** BREAK ***																	
10:30	5	185	22	0	6	16	3	0	24	99	6	0	3	11	23	0	403
10:45	4	144	13	0	5	20	6	0	14	93	4	0	18	12	22	0	355
Total	9	329	35	0	11	36	9	0	38	192	10	0	21	23	45	0	758
11:00	8	140	12	0	9	8	2	0	22	104	7	0	12	9	23	0	356
11:15	5	172	14	0	5	21	8	0	22	134	10	0	14	9	27	0	441
11:30	4	128	9	0	7	14	5	0	21	157	9	0	25	16	43	0	438
11:45	7	214	18	0	14	13	7	0	27	144	7	0	20	15	37	0	523
Total	24	654	53	0	35	56	22	0	92	539	33	0	71	49	130	0	1758
12:00	6	142	13	0	9	15	6	0	25	122	13	0	15	16	38	0	420
12:15	9	198	22	0	13	12	8	0	30	129	11	0	14	17	27	0	490
12:30	0	157	8	0	11	12	9	0	22	165	8	0	17	12	29	0	450
12:45	8	175	17	0	14	21	7	0	35	178	18	0	15	14	25	0	527
Total	23	672	60	0	47	60	30	0	112	594	50	0	61	59	119	0	1887
13:00	6	147	8	0	9	16	13	0	27	177	15	0	19	12	20	0	469
13:15	6	141	13	0	9	15	7	0	30	162	8	0	20	16	27	0	454
*** BREAK ***																	
Total	12	288	21	0	18	31	20	0	57	339	23	0	39	28	47	0	923
*** BREAK ***																	
14:30	2	167	14	0	9	19	6	0	23	250	12	0	51	42	39	0	634
14:45	6	157	22	0	5	22	12	0	26	313	21	0	40	37	49	0	710
Total	8	324	36	0	14	41	18	0	49	563	33	0	91	79	88	0	1344
15:00	9	141	11	0	9	18	19	0	40	302	14	0	30	11	20	0	624
15:15	12	127	17	0	10	32	25	2	36	323	14	0	40	29	36	0	703
15:30	6	174	6	0	10	32	26	0	29	392	21	0	38	16	33	0	783
15:45	3	180	21	0	10	33	37	0	47	375	10	0	46	31	39	0	832
Total	30	622	55	0	39	115	107	2	152	1392	59	0	154	87	128	0	2942

# Alliant Engineering Inc

## Minneapolis, MN 55415

TH-65 at Bunker Lake Blvd NE  
 Ref.Pt.: 016.928 HAM LAKE  
 data by Alliant Engineering Inc  
 TURN MOVEMENT COUNT

File Name : TH-65 at Bunker Lake Blvd NE 2009  
 Site Code : 00000018  
 Start Date : 1/28/2009  
 Page No : 2

**Groups Printed- Unshifted**

Start Time	TH-65 Southbound				Bunker Lake Blvd NE Westbound				TH-65 Northbound				Bunker Lake Blvd NE Eastbound				Int. Total
	Left	Thru	Right	Peds	Left	Thru	Right	Peds	Left	Thru	Right	Peds	Left	Thru	Right	Peds	
16:00	3	194	14	0	9	42	20	0	50	450	18	0	39	32	46	0	917
16:15	4	134	12	0	19	45	34	0	41	378	22	0	46	32	36	0	803
16:30	8	201	12	0	13	41	17	0	53	423	16	0	54	39	41	0	918
16:45	9	170	17	0	15	66	38	1	47	421	12	0	55	24	26	0	901
Total	24	699	55	0	56	194	109	1	191	1672	68	0	194	127	149	0	3539
17:00	15	151	79	0	21	51	31	0	39	403	23	0	67	46	53	0	979
17:15	24	201	21	0	15	57	30	0	43	482	11	0	54	53	43	0	1034
17:30	14	161	13	0	13	45	29	0	49	367	18	0	78	43	40	0	870
17:45	8	178	23	0	12	38	31	0	50	386	15	0	48	26	33	0	848
Total	61	691	136	0	61	191	121	0	181	1638	67	0	247	168	169	0	3731
Grand Total	294	9228	870	1	477	1196	517	3	1144	8019	441	0	1039	979	1363	0	25571
Apprch %	2.8	88.8	8.4	0	21.8	54.5	23.6	0.1	11.9	83.5	4.6	0	30.7	29	40.3	0	
Total %	1.1	36.1	3.4	0	1.9	4.7	2	0	4.5	31.4	1.7	0	4.1	3.8	5.3	0	

# Alliant Engineering Inc Minneapolis, MN 55415

TH-65 at Bunker Lake Blvd NE  
Ref.Pt.: 016.928 HAM LAKE  
data by Alliant Engineering Inc  
TURN MOVEMENT COUNT

File Name : TH-65 at Bunker Lake Blvd NE 2009  
Site Code : 00000018  
Start Date : 1/28/2009  
Page No : 3

Start Time	TH-65 Southbound					Bunker Lake Blvd NE Westbound					TH-65 Northbound					Bunker Lake Blvd NE Eastbound					Int. Total
	Left	Thru	Right	Peds	App. Total	Left	Thru	Right	Peds	App. Total	Left	Thru	Right	Peds	App. Total	Left	Thru	Right	Peds	App. Total	
Peak Hour Analysis From 06:00 to 08:45 - Peak 1 of 1																					
Peak Hour for Entire Intersection Begins at 07:00																					
07:00	12	420	28	0	460	12	44	3	0	59	15	69	5	0	89	6	39	44	0	89	697
07:15	0	<b>444</b>	45	1	490	19	67	3	0	89	23	83	7	0	113	10	31	<b>51</b>	0	92	784
07:30	<b>16</b>	420	<b>60</b>	0	<b>496</b>	14	59	<b>9</b>	0	82	28	<b>109</b>	4	0	<b>141</b>	14	<b>49</b>	34	0	<b>97</b>	<b>816</b>
07:45	5	376	60	0	441	<b>27</b>	<b>80</b>	6	0	<b>113</b>	<b>31</b>	94	<b>8</b>	0	133	<b>20</b>	41	36	0	97	784
Total Volume	33	1660	193	1	1887	72	250	21	0	343	97	355	24	0	476	50	160	165	0	375	3081
% App. Total	1.7	88	10.2	0.1		21	72.9	6.1	0		20.4	74.6	5	0		13.3	42.7	44	0		
PHF	.516	.935	.804	.250	.951	.667	.781	.583	.000	.759	.782	.814	.750	.000	.844	.625	.816	.809	.000	.966	.944

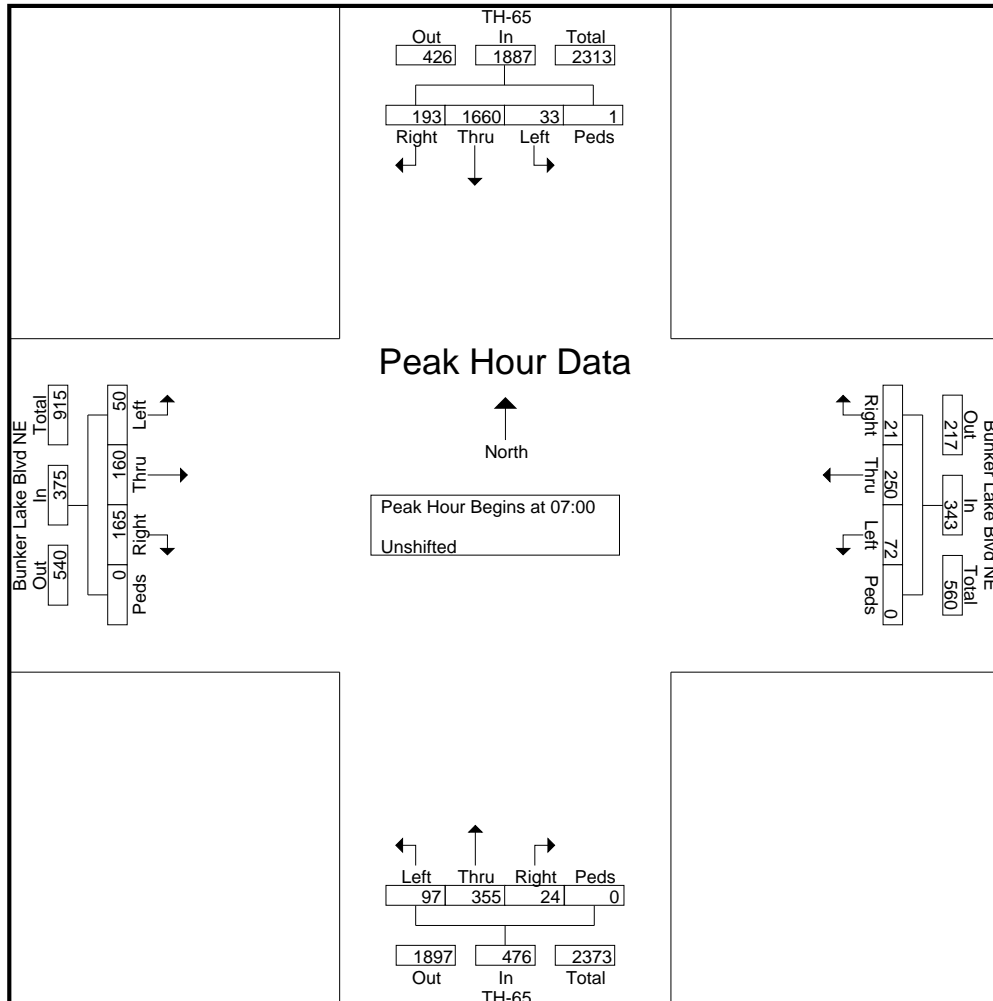

# Alliant Engineering Inc Minneapolis, MN 55415

TH-65 at Bunker Lake Blvd NE  
Ref.Pt.: 016.928 HAM LAKE  
data by Alliant Engineering Inc  
TURN MOVEMENT COUNT

File Name : TH-65 at Bunker Lake Blvd NE 2009  
Site Code : 00000018  
Start Date : 1/28/2009  
Page No : 4

Start Time	TH-65 Southbound					Bunker Lake Blvd NE Westbound					TH-65 Northbound					Bunker Lake Blvd NE Eastbound					Int. Total
	Left	Thru	Right	Peds	App. Total	Left	Thru	Right	Peds	App. Total	Left	Thru	Right	Peds	App. Total	Left	Thru	Right	Peds	App. Total	
Peak Hour Analysis From 15:00 to 17:45 - Peak 1 of 1																					
Peak Hour for Entire Intersection Begins at 16:30																					
16:30	8	201	12	0	221	13	41	17	0	71	53	423	16	0	492	54	39	41	0	134	918
16:45	9	170	17	0	196	15	66	38	1	120	47	421	12	0	480	55	24	26	0	105	901
17:00	15	151	79	0	245	21	51	31	0	103	39	403	23	0	465	67	46	53	0	166	979
17:15	24	201	21	0	246	15	57	30	0	102	43	482	11	0	536	54	53	43	0	150	1034
Total Volume	56	723	129	0	908	64	215	116	1	396	182	1729	62	0	1973	230	162	163	0	555	3832
% App. Total	6.2	79.6	14.2	0		16.2	54.3	29.3	0.3		9.2	87.6	3.1	0		41.4	29.2	29.4	0		
PHF	.583	.899	.408	.000	.923	.762	.814	.763	.250	.825	.858	.897	.674	.000	.920	.858	.764	.769	.000	.836	.926

