

MN Dept of Transportation

TRAFFIC DATA COLLECTION - Metro

TH-65 at 157th Ave NE HAM LAKE
 Ref.Pt.: 019.498
 video AL
 TURN MOVEMENT COUNT

File Name : th-65 at 157th ave 2016
 Site Code :
 Start Date : 3/2/2016
 Page No : 1

Groups Printed- Cars +

Start Time	TH-65 Southbound				157th Ave Westbound				TH-65 Northbound				157th Ave Eastbound				Int. Total
	Left	Thru	Right	Peds	Left	Thru	Right	Peds	Left	Thru	Right	Peds	Left	Thru	Right	Peds	
06:00	1	474	1	0	0	1	0	0	10	41	1	0	1	0	11	0	541
06:15	1	526	0	0	0	0	1	0	4	96	0	0	6	0	11	0	645
06:30	0	578	0	0	1	0	0	0	3	95	0	0	0	0	19	0	696
06:45	1	490	4	0	1	0	1	0	4	98	0	0	3	0	13	0	615
Total	3	2068	5	0	2	1	2	0	21	330	1	0	10	0	54	0	2497
07:00	2	509	2	0	0	0	2	0	12	123	0	0	4	0	14	0	668
07:15	1	573	4	0	0	0	2	0	9	131	0	0	8	0	23	0	751
07:30	1	542	3	0	0	0	2	0	15	158	1	0	4	0	20	0	746
07:45	0	523	2	0	0	1	2	0	23	158	0	0	4	0	29	0	742
Total	4	2147	11	0	0	1	8	0	59	570	1	0	20	0	86	0	2907
08:00	3	399	3	0	1	0	1	0	9	135	0	0	7	1	21	0	580
08:15	0	370	4	0	0	2	1	0	14	112	0	0	9	0	12	0	524
08:30	1	340	4	0	0	1	1	0	7	146	1	0	2	1	20	0	524
08:45	3	305	5	0	2	1	2	0	15	161	0	0	3	0	15	0	512
Total	7	1414	16	0	3	4	5	0	45	554	1	0	21	2	68	0	2140
09:00	0	257	8	0	0	0	0	0	11	135	0	0	5	0	9	0	425
09:15	1	263	4	0	1	1	2	0	12	166	2	0	6	0	7	0	465
09:30	6	268	4	0	0	0	0	0	4	162	3	0	6	3	13	0	469
09:45	0	243	5	0	0	0	2	0	9	136	0	0	7	0	20	0	422
Total	7	1031	21	0	1	1	4	0	36	599	5	0	24	3	49	0	1781
10:00	0	208	7	0	0	0	0	0	5	121	4	0	3	0	11	0	359
10:15	2	190	2	0	0	0	1	0	12	122	0	0	3	0	9	0	341
10:30	1	228	4	0	1	0	0	0	7	161	1	0	3	1	10	0	417
10:45	1	217	1	0	1	0	3	0	13	160	3	0	7	0	15	0	421
Total	4	843	14	0	2	0	4	0	37	564	8	0	16	1	45	0	1538
11:00	3	222	5	0	3	1	4	0	15	147	3	0	5	0	17	0	425
11:15	2	208	3	0	1	0	3	0	17	172	0	0	1	0	13	0	420
11:30	0	204	8	0	0	0	1	0	8	142	3	0	8	2	15	0	391
11:45	1	203	5	0	3	1	4	0	9	188	1	0	15	0	8	0	438
Total	6	837	21	0	7	2	12	0	49	649	7	0	29	2	53	0	1674
12:00	2	202	5	0	3	1	3	0	10	178	4	0	11	0	12	0	431
12:15	3	196	2	0	5	2	1	0	12	186	1	0	5	0	10	0	423
12:30	0	187	5	0	2	1	3	0	15	210	2	0	8	0	8	0	441
12:45	1	202	6	0	0	0	1	0	12	226	1	0	10	1	9	0	469
Total	6	787	18	0	10	4	8	0	49	800	8	0	34	1	39	0	1764
13:00	1	193	3	0	2	0	1	0	10	212	3	0	4	0	6	0	435
13:15	2	208	4	0	0	0	1	0	13	260	1	0	8	1	12	0	510
13:30	2	228	2	0	1	1	1	0	9	229	1	0	4	0	7	0	485
13:45	0	212	3	0	2	0	0	0	11	293	0	0	4	0	7	0	532
Total	5	841	12	0	5	1	3	0	43	994	5	0	20	1	32	0	1962
14:00	1	197	4	0	1	0	5	0	5	243	0	0	5	0	12	0	473
14:15	2	215	2	0	0	0	0	0	18	257	0	0	7	1	10	0	512
14:30	0	156	8	0	0	2	1	0	16	370	1	0	6	0	15	0	575
14:45	0	165	5	0	0	0	1	0	21	361	0	0	6	0	24	0	583
Total	3	733	19	0	1	2	7	0	60	1231	1	0	24	1	61	0	2143
15:00	2	204	10	0	1	1	0	0	23	437	2	0	6	2	20	0	708
15:15	0	209	3	0	1	2	2	0	26	508	2	0	7	1	18	0	779
15:30	0	238	1	0	2	0	3	0	25	526	2	0	8	2	24	0	831
15:45	1	212	2	0	1	1	2	0	23	539	2	0	8	0	15	0	806
Total	3	863	16	0	5	4	7	0	97	2010	8	0	29	5	77	0	3124

MN Dept of Transportation

TRAFFIC DATA COLLECTION - Metro

TH-65 at 157th Ave NE HAM LAKE
 Ref.Pt.: 019.498
 video AL
 TURN MOVEMENT COUNT

File Name : th-65 at 157th ave 2016
 Site Code :
 Start Date : 3/2/2016
 Page No : 2

Groups Printed- Cars +

Start Time	TH-65 Southbound				157th Ave Westbound				TH-65 Northbound				157th Ave Eastbound				Int. Total
	Left	Thru	Right	Peds	Left	Thru	Right	Peds	Left	Thru	Right	Peds	Left	Thru	Right	Peds	
16:00	1	230	10	0	3	2	0	0	13	554	1	0	4	0	11	0	829
16:15	2	180	2	0	0	0	1	0	32	581	1	0	5	2	16	0	822
16:30	1	253	6	0	1	1	0	0	35	537	1	0	14	1	27	0	877
16:45	1	250	5	0	0	0	0	0	41	636	0	0	4	2	19	0	958
Total	5	913	23	0	4	3	1	0	121	2308	3	0	27	5	73	0	3486
17:00	0	266	8	0	0	0	1	0	31	598	1	0	8	2	21	0	936
17:15	0	269	1	0	0	1	2	0	18	544	1	0	4	1	13	0	854
17:30	1	215	6	0	0	1	0	0	24	510	2	0	9	2	11	0	781
17:45	1	176	4	0	0	1	2	0	27	468	3	0	8	1	7	0	698
Total	2	926	19	0	0	3	5	0	100	2120	7	0	29	6	52	0	3269
Grand Total	55	13403	195	0	40	26	66	0	717	12729	55	0	283	27	689	0	28285
Apprch %	0.4	98.2	1.4	0	30.3	19.7	50	0	5.3	94.3	0.4	0	28.3	2.7	69	0	
Total %	0.2	47.4	0.7	0	0.1	0.1	0.2	0	2.5	45	0.2	0	1	0.1	2.4	0	

MN Dept of Transportation

TRAFFIC DATA COLLECTION - Metro

TH-65 at 157th Ave NE HAM LAKE
 Ref.Pt.: 019.498
 video AL
 TURN MOVEMENT COUNT

File Name : th-65 at 157th ave 2016
 Site Code :
 Start Date : 3/2/2016
 Page No : 3

Start Time	TH-65 Southbound					157th Ave Westbound					TH-65 Northbound					157th Ave Eastbound					Int. Total
	Left	Thru	Right	Peds	App. Total	Left	Thru	Right	Peds	App. Total	Left	Thru	Right	Peds	App. Total	Left	Thru	Right	Peds	App. Total	
Peak Hour Analysis From 06:00 to 11:45 - Peak 1 of 1																					
Peak Hour for Entire Intersection Begins at 07:00																					
07:00	2	509	2	0	513	0	0	2	0	2	12	123	0	0	135	4	0	14	0	18	668
07:15	1	573	4	0	578	0	0	2	0	2	9	131	0	0	140	8	0	23	0	31	751
07:30	1	542	3	0	546	0	0	2	0	2	15	158	1	0	174	4	0	20	0	24	746
07:45	0	523	2	0	525	0	1	2	0	3	23	158	0	0	181	4	0	29	0	33	742
Total Volume	4	2147	11	0	2162	0	1	8	0	9	59	570	1	0	630	20	0	86	0	106	2907
% App. Total	0.2	99.3	0.5	0		0	11.1	88.9	0		9.4	90.5	0.2	0		18.9	0	81.1	0		
PHF	.500	.937	.688	.000	.935	.000	.250	1.00	.000	.750	.641	.902	.250	.000	.870	.625	.000	.741	.000	.803	.968

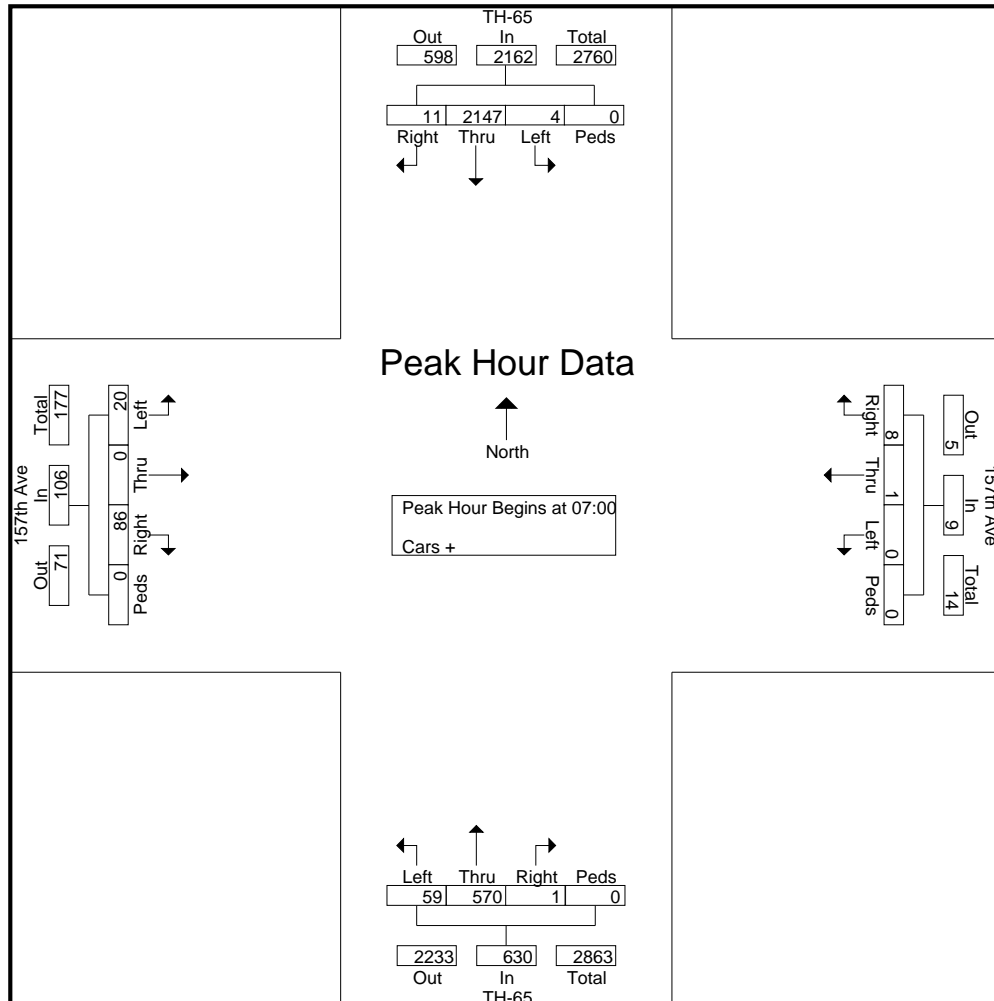

MN Dept of Transportation

TRAFFIC DATA COLLECTION - Metro

TH-65 at 157th Ave NE HAM LAKE
 Ref.Pt.: 019.498
 video AL
 TURN MOVEMENT COUNT

File Name : th-65 at 157th ave 2016
 Site Code :
 Start Date : 3/2/2016
 Page No : 4

Start Time	TH-65 Southbound					157th Ave Westbound					TH-65 Northbound					157th Ave Eastbound					Int. Total
	Left	Thru	Right	Peds	App. Total	Left	Thru	Right	Peds	App. Total	Left	Thru	Right	Peds	App. Total	Left	Thru	Right	Peds	App. Total	
Peak Hour Analysis From 12:00 to 17:45 - Peak 1 of 1																					
Peak Hour for Entire Intersection Begins at 16:30																					
16:30	1	253	6	0	260	1	1	0	0	2	35	537	1	0	573	14	1	27	0	42	877
16:45	1	250	5	0	256	0	0	0	0	0	41	636	0	0	677	4	2	19	0	25	958
17:00	0	266	8	0	274	0	0	1	0	1	31	598	1	0	630	8	2	21	0	31	936
17:15	0	269	1	0	270	0	1	2	0	3	18	544	1	0	563	4	1	13	0	18	854
Total Volume	2	1038	20	0	1060	1	2	3	0	6	125	2315	3	0	2443	30	6	80	0	116	3625
% App. Total	0.2	97.9	1.9	0		16.7	33.3	50	0		5.1	94.8	0.1	0		25.9	5.2	69	0		
PHF	.500	.965	.625	.000	.967	.250	.500	.375	.000	.500	.762	.910	.750	.000	.902	.536	.750	.741	.000	.690	.946

