



MINNESOTA DEPT OF TRANSPORTATION

TRAFFIC DATA COLLECTION - METRO

TH-7 at Minnewashta Parkway
 Ref.Pt.: 180.171
 JAMAR # D4-3365 CH
 TURN MOVEMENT COUNT

File Name : TH-7 at Minnewashta Pkwy 2009
 Site Code : 00000000
 Start Date : 7/16/2009
 Page No : 1

Groups Printed- Cars & Trucks

Start Time	MINNEWASHTA PKWY Southbound				TH-7 Westbound				MINNEWASHTA PKWY Northbound				TH-7 Eastbound				Int. Total
	Left	Thru	Right	Peds	Left	Thru	Right	Peds	Left	Thru	Right	Peds	Left	Thru	Right	Peds	
06:00	6	1	1	0	1	25	3	0	2	1	7	0	0	132	0	1	180
06:15	11	2	1	1	2	35	3	0	0	0	16	0	1	141	0	1	214
06:30	11	1	2	0	2	37	0	0	0	0	10	0	1	163	0	0	227
06:45	8	5	1	1	1	42	2	1	0	0	17	0	3	195	2	1	279
Total	36	9	5	2	6	139	8	1	2	1	50	0	5	631	2	3	900
07:00	10	1	2	0	1	46	5	0	0	0	13	0	2	247	0	0	327
07:15	18	1	0	0	6	39	3	0	1	1	22	0	0	246	0	0	337
07:30	23	2	0	1	3	44	5	0	0	0	30	0	3	247	2	1	361
07:45	11	1	0	2	10	75	7	0	2	1	29	0	8	185	2	1	334
Total	62	5	2	3	20	204	20	0	3	2	94	0	13	925	4	2	1359
08:00	14	3	2	0	4	49	5	0	0	3	13	0	2	185	0	1	281
08:15	8	6	3	2	8	71	6	0	0	2	15	0	2	183	2	0	308
08:30	14	4	0	0	5	87	3	0	0	2	29	0	1	167	0	0	312
08:45	18	4	3	0	6	65	8	0	0	1	22	0	3	139	2	0	271
Total	54	17	8	2	23	272	22	0	0	8	79	0	8	674	4	1	1172
*** Break***																	
15:00	7	1	1	0	15	137	13	0	2	6	11	0	1	105	1	1	301
15:15	4	1	1	0	15	110	3	0	0	6	7	0	1	88	1	0	237
15:30	6	1	5	4	28	189	16	0	0	5	12	0	1	103	0	0	370
15:45	6	3	3	0	15	186	14	0	0	5	15	0	4	122	4	0	377
Total	23	6	10	4	73	622	46	0	2	22	45	0	7	418	6	1	1285
16:00	6	2	5	0	21	183	14	0	1	1	16	0	3	99	4	0	355
16:15	14	3	2	0	16	230	13	0	3	3	15	0	2	94	2	0	397
16:30	8	3	1	0	19	254	18	0	4	3	16	0	2	108	3	0	439
16:45	8	1	5	0	25	221	16	0	5	4	22	0	2	89	1	0	399
Total	36	9	13	0	81	888	61	0	13	11	69	0	9	390	10	0	1590
17:00	5	1	6	0	31	293	20	0	4	7	24	0	4	90	2	1	488
17:15	6	1	1	0	22	285	21	1	1	6	20	0	1	93	1	0	459
17:30	12	6	3	0	36	268	20	0	3	5	29	0	2	106	2	3	495
17:45	11	2	1	0	24	203	24	0	2	5	15	0	4	87	5	1	384
Total	34	10	11	0	113	1049	85	1	10	23	88	0	11	376	10	5	1826
Grand Total	245	56	49	11	316	3174	242	2	30	67	425	0	53	3414	36	12	8132
Apprch %	67.9	15.5	13.6	3	8.5	85	6.5	0.1	5.7	12.8	81.4	0	1.5	97.1	1	0.3	
Total %	3	0.7	0.6	0.1	3.9	39	3	0	0.4	0.8	5.2	0	0.7	42	0.4	0.1	



MINNESOTA DEPT OF TRANSPORTATION

TRAFFIC DATA COLLECTION - METRO

TH-7 at Minnewashta Parkway
 Ref.Pt.: 180.171
 JAMAR # D4-3365 CH
 TURN MOVEMENT COUNT

File Name : TH-7 at Minnewashta Pkwy 2009
 Site Code : 00000000
 Start Date : 7/16/2009
 Page No : 2

Start Time	MINNEWASHTA PKWY Southbound					TH-7 Westbound					MINNEWASHTA PKWY Northbound					TH-7 Eastbound					Int. Total
	Left	Thru	Right	Peds	App. Total	Left	Thru	Right	Peds	App. Total	Left	Thru	Right	Peds	App. Total	Left	Thru	Right	Peds	App. Total	
Peak Hour Analysis From 06:00 to 08:45 - Peak 1 of 1																					
Peak Hour for Entire Intersection Begins at 07:00																					
07:00	10	1	2	0	13	1	46	5	0	52	0	0	13	0	13	2	247	0	0	249	327
07:15	18	1	0	0	19	6	39	3	0	48	1	1	22	0	24	0	246	0	0	246	337
07:30	23	2	0	1	26	3	44	5	0	52	0	0	30	0	30	3	247	2	1	253	361
07:45	11	1	0	2	14	10	75	7	0	92	2	1	29	0	32	8	185	2	1	196	334
Total Volume	62	5	2	3	72	20	204	20	0	244	3	2	94	0	99	13	925	4	2	944	1359
% App. Total	86.1	6.9	2.8	4.2		8.2	83.6	8.2	0		3	2	94.9	0		1.4	98	0.4	0.2		
PHF	.674	.625	.250	.375	.692	.500	.680	.714	.000	.663	.375	.500	.783	.000	.773	.406	.936	.500	.500	.933	.941

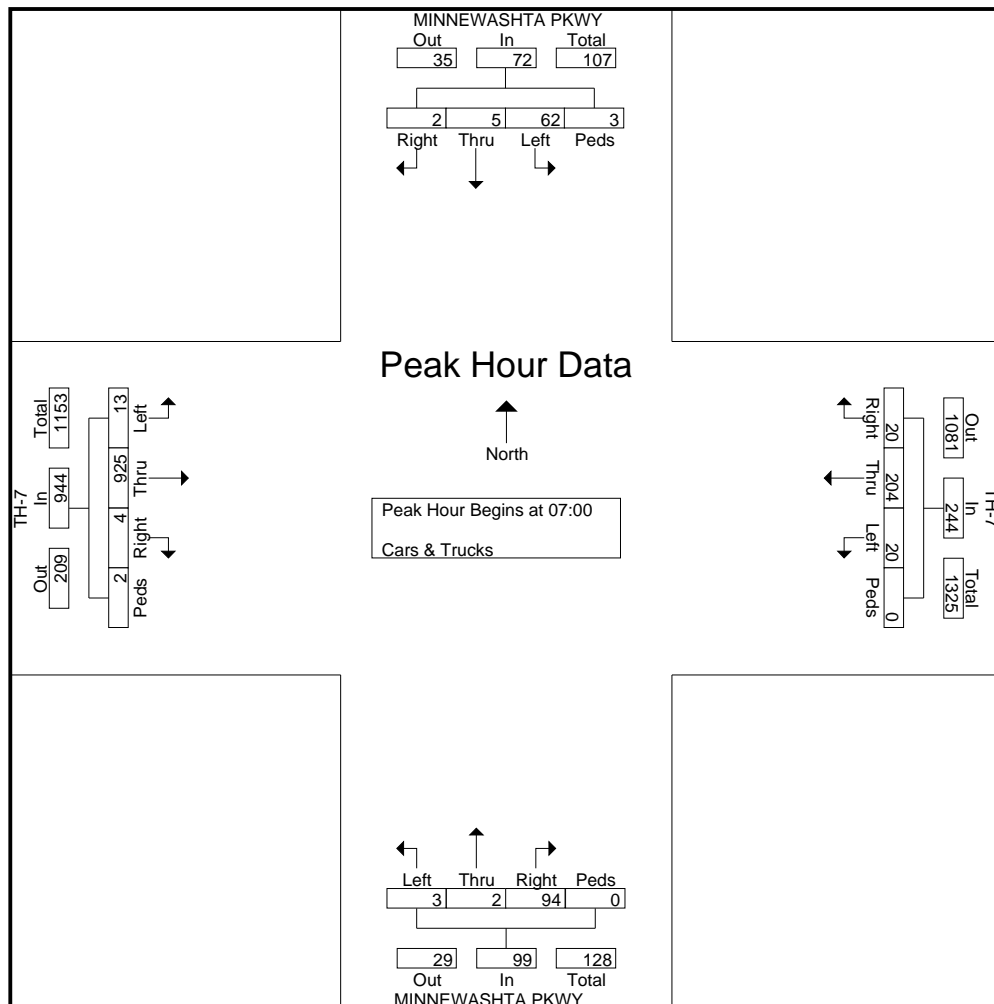



MINNESOTA DEPT OF TRANSPORTATION

TRAFFIC DATA COLLECTION - METRO

TH-7 at Minnewashta Parkway
 Ref.Pt.: 180.171
 JAMAR # D4-3365 CH
 TURN MOVEMENT COUNT

File Name : TH-7 at Minnewashta Pkwy 2009
 Site Code : 00000000
 Start Date : 7/16/2009
 Page No : 3

Start Time	MINNEWASHTA PKWY Southbound					TH-7 Westbound					MINNEWASHTA PKWY Northbound					TH-7 Eastbound					Int. Total
	Left	Thru	Right	Peds	App. Total	Left	Thru	Right	Peds	App. Total	Left	Thru	Right	Peds	App. Total	Left	Thru	Right	Peds	App. Total	
Peak Hour Analysis From 15:00 to 17:45 - Peak 1 of 1																					
Peak Hour for Entire Intersection Begins at 16:45																					
16:45	8	1	5	0	14	25	221	16	0	262	5	4	22	0	31	2	89	1	0	92	399
17:00	5	1	6	0	12	31	293	20	0	344	4	7	24	0	35	4	90	2	1	97	488
17:15	6	1	1	0	8	22	285	21	1	329	1	6	20	0	27	1	93	1	0	95	459
17:30	12	6	3	0	21	36	268	20	0	324	3	5	29	0	37	2	106	2	3	113	495
Total Volume	31	9	15	0	55	114	1067	77	1	1259	13	22	95	0	130	9	378	6	4	397	1841
% App. Total	56.4	16.4	27.3	0		9.1	84.7	6.1	0.1		10	16.9	73.1	0		2.3	95.2	1.5	1		
PHF	.646	.375	.625	.000	.655	.792	.910	.917	.250	.915	.650	.786	.819	.000	.878	.563	.892	.750	.333	.878	.930

