

Alliant Engineering Inc Minneapolis, MN 55415

TH-7 at Williston Rd.
Ref.Pt.: 188.039
Alliant Engineering Inc
TURN MOVEMENT COUNT

File Name : 11_TH 7 at Williston Rd_011211
Site Code : 00000011
Start Date : 1/12/2011
Page No : 1

Groups Printed- Unshifted - Bank 1

Start Time	Williston Rd Southbound					TH-7 Westbound					Williston Rd Northbound					TH-7 Eastbound					Int. Total
	Left	Thru	Right	Peds	App. Total	Left	Thru	Right	Peds	App. Total	Left	Thru	Right	Peds	App. Total	Left	Thru	Right	Peds	App. Total	
06:00	13	4	1	0	18	8	63	3	0	74	3	2	6	0	11	7	194	1	0	202	305
06:15	24	5	1	0	30	10	92	2	0	104	1	3	14	0	18	6	257	0	0	263	415
06:30	24	3	5	0	32	11	116	9	0	136	2	1	19	0	22	4	380	2	0	386	576
06:45	31	5	2	0	38	11	159	12	0	182	5	6	30	0	41	16	399	3	0	418	679
Total	92	17	9	0	118	40	430	26	0	496	11	12	69	0	92	33	1230	6	0	1269	1975
07:00	36	20	2	0	58	18	150	6	0	174	3	13	40	0	56	24	489	3	1	517	805
07:15	32	32	16	0	80	14	166	10	0	190	7	15	66	0	88	22	596	2	0	620	978
07:30	37	20	25	0	82	24	194	18	0	236	7	14	60	0	81	13	582	6	0	601	1000
07:45	40	22	23	0	85	23	226	16	0	265	8	28	42	0	78	31	595	10	0	636	1064
Total	145	94	66	0	305	79	736	50	0	865	25	70	208	0	303	90	2262	21	1	2374	3847
08:00	37	18	12	0	67	23	202	16	0	241	2	11	29	0	42	28	617	4	0	649	999
08:15	35	15	8	0	58	21	189	18	0	228	5	12	37	0	54	13	607	8	0	628	968
08:30	50	19	9	0	78	31	185	13	0	229	9	12	33	0	54	15	459	5	0	479	840
08:45	40	13	12	0	65	26	241	25	0	292	10	22	28	0	60	29	421	2	0	452	869
Total	162	65	41	0	268	101	817	72	0	990	26	57	127	0	210	85	2104	19	0	2208	3676
09:00	38	14	7	0	59	20	204	14	0	238	12	20	18	0	50	11	320	7	0	338	685
09:15	36	7	8	0	51	29	186	23	0	238	6	11	20	0	37	23	325	2	0	350	676
*** BREAK ***																					
Total	74	21	15	0	110	49	390	37	0	476	18	31	38	0	87	34	645	9	0	688	1361
*** BREAK ***																					
10:30	22	9	9	0	40	41	194	12	0	247	9	12	15	0	36	8	277	4	0	289	612
10:45	27	11	10	0	48	25	197	11	0	233	19	9	22	0	50	16	246	5	0	267	598
Total	49	20	19	0	88	66	391	23	0	480	28	21	37	0	86	24	523	9	0	556	1210
11:00	21	7	18	0	46	26	224	7	0	257	8	6	16	0	30	8	247	12	0	267	600
11:15	32	22	10	0	64	37	204	13	0	254	15	14	17	0	46	12	272	9	0	293	657
11:30	37	15	25	0	77	38	240	16	0	294	19	13	15	0	47	19	272	12	0	303	721
11:45	36	13	29	0	78	32	209	8	0	249	13	10	18	0	41	19	252	11	0	282	650
Total	126	57	82	0	265	133	877	44	0	1054	55	43	66	0	164	58	1043	44	0	1145	2628
12:00	32	17	34	0	83	44	236	22	0	302	16	5	16	0	37	28	245	16	0	289	711
12:15	34	17	15	0	66	44	232	8	0	284	15	16	11	0	42	23	243	17	0	283	675
12:30	30	19	9	0	58	43	216	14	0	273	19	25	28	0	72	30	270	5	0	305	708
12:45	45	12	17	0	74	33	211	17	0	261	19	21	17	0	57	21	241	10	0	272	664
Total	141	65	75	0	281	164	895	61	0	1120	69	67	72	0	208	102	999	48	0	1149	2758
13:00	29	16	20	0	65	41	209	17	1	268	18	18	14	0	50	14	219	16	0	249	632
13:15	22	12	10	0	44	30	215	22	0	267	17	16	15	0	48	18	241	14	0	273	632
*** BREAK ***																					
Total	51	28	30	0	109	71	424	39	1	535	35	34	29	0	98	32	460	30	0	522	1264
*** BREAK ***																					
14:30	28	11	13	0	52	26	324	15	0	365	16	6	11	0	33	13	266	3	0	282	732
14:45	20	17	17	0	54	62	316	28	0	406	22	14	12	0	48	18	271	10	0	299	807
Total	48	28	30	0	106	88	640	43	0	771	38	20	23	0	81	31	537	13	0	581	1539
15:00	25	18	21	0	64	44	307	31	0	382	16	19	8	0	43	23	267	7	0	297	786
15:15	38	10	21	0	69	51	304	33	0	388	18	14	18	0	50	20	214	3	0	237	744
15:30	23	24	26	0	73	50	372	26	0	448	21	33	14	0	68	25	320	11	0	356	945
15:45	23	44	19	0	86	40	370	46	0	456	20	38	6	0	64	29	245	25	0	299	905
Total	109	96	87	0	292	185	1353	136	0	1674	75	104	46	0	225	97	1046	46	0	1189	3380
16:00	54	26	29	0	109	36	369	27	0	432	21	26	17	0	64	36	258	14	0	308	913

Alliant Engineering Inc

Minneapolis, MN 55415

TH-7 at Williston Rd.
 Ref.Pt.: 188.039
 Alliant Engineering Inc
 TURN MOVEMENT COUNT

File Name : 11_TH 7 at Williston Rd_011211
 Site Code : 00000011
 Start Date : 1/12/2011
 Page No : 2

Groups Printed- Unshifted - Bank 1

Start Time	Williston Rd Southbound					TH-7 Westbound					Williston Rd Northbound					TH-7 Eastbound					Int. Total
	Left	Thru	Right	Peds	App. Total	Left	Thru	Right	Peds	App. Total	Left	Thru	Right	Peds	App. Total	Left	Thru	Right	Peds	App. Total	
16:15	37	35	27	0	99	39	468	28	0	535	19	21	26	0	66	30	289	11	0	330	1030
16:30	52	24	29	0	105	49	409	17	0	475	18	24	12	0	54	11	274	7	0	292	926
16:45	45	22	30	0	97	41	469	10	0	520	19	27	11	0	57	39	311	8	0	358	1032
Total	188	107	115	0	410	165	1715	82	0	1962	77	98	66	0	241	116	1132	40	0	1288	3901
17:00	51	43	31	0	125	49	494	36	0	579	17	29	14	0	60	26	234	12	0	272	1036
17:15	37	37	37	0	111	35	498	19	1	553	23	24	11	0	58	31	276	9	0	316	1038
17:30	29	28	34	0	91	60	485	20	0	565	28	34	11	0	73	29	230	5	0	264	993
17:45	20	35	29	0	84	37	446	23	0	506	25	23	10	0	58	29	291	8	0	328	976
Total	137	143	131	0	411	181	1923	98	1	2203	93	110	46	0	249	115	1031	34	0	1180	4043
Grand Total	1322	741	700	0	2763	1322	10591	711	2	12626	550	667	827	0	2044	817	13012	319	1	14149	31582
Apprch %	47.8	26.8	25.3	0		10.5	83.9	5.6	0		26.9	32.6	40.5	0		5.8	92	2.3	0		
Total %	4.2	2.3	2.2	0	8.7	4.2	33.5	2.3	0	40	1.7	2.1	2.6	0	6.5	2.6	41.2	1	0	44.8	
Unshifted	1295	726	689	0	2710	1292	10352	693	2	12339	537	642	813	0	1992	792	12786	316	1	13895	30936
% Unshifted	98	98	98.4	0	98.1	97.7	97.7	97.5	100	97.7	97.6	96.3	98.3	0	97.5	96.9	98.3	99.1	100	98.2	98
Bank 1	27	15	11	0	53	30	239	18	0	287	13	25	14	0	52	25	226	3	0	254	646
% Bank 1	2	2	1.6	0	1.9	2.3	2.3	2.5	0	2.3	2.4	3.7	1.7	0	2.5	3.1	1.7	0.9	0	1.8	2

Alliant Engineering Inc Minneapolis, MN 55415

TH-7 at Williston Rd.
Ref.Pt.: 188.039
Alliant Engineering Inc
TURN MOVEMENT COUNT

File Name : 11_TH 7 at Williston Rd_011211
Site Code : 00000011
Start Date : 1/12/2011
Page No : 3

Start Time	Williston Rd Southbound					TH-7 Westbound					Williston Rd Northbound					TH-7 Eastbound					Int. Total
	Left	Thru	Right	Peds	App. Total	Left	Thru	Right	Peds	App. Total	Left	Thru	Right	Peds	App. Total	Left	Thru	Right	Peds	App. Total	
Peak Hour Analysis From 06:00 to 09:15 - Peak 1 of 1																					
Peak Hour for Entire Intersection Begins at 07:15																					
07:15	32	32	16	0	80	14	166	10	0	190	7	15	66	0	88	22	596	2	0	620	978
07:30	37	20	25	0	82	24	194	18	0	236	7	14	60	0	81	13	582	6	0	601	1000
07:45	40	22	23	0	85	23	226	16	0	265	8	28	42	0	78	31	595	10	0	636	1064
08:00	37	18	12	0	67	23	202	16	0	241	2	11	29	0	42	28	617	4	0	649	999
Total Volume	146	92	76	0	314	84	788	60	0	932	24	68	197	0	289	94	2390	22	0	2506	4041
% App. Total	46.5	29.3	24.2	0		9	84.5	6.4	0		8.3	23.5	68.2	0		3.8	95.4	0.9	0		
PHF	.913	.719	.760	.000	.924	.875	.872	.833	.000	.879	.750	.607	.746	.000	.821	.758	.968	.550	.000	.965	.949

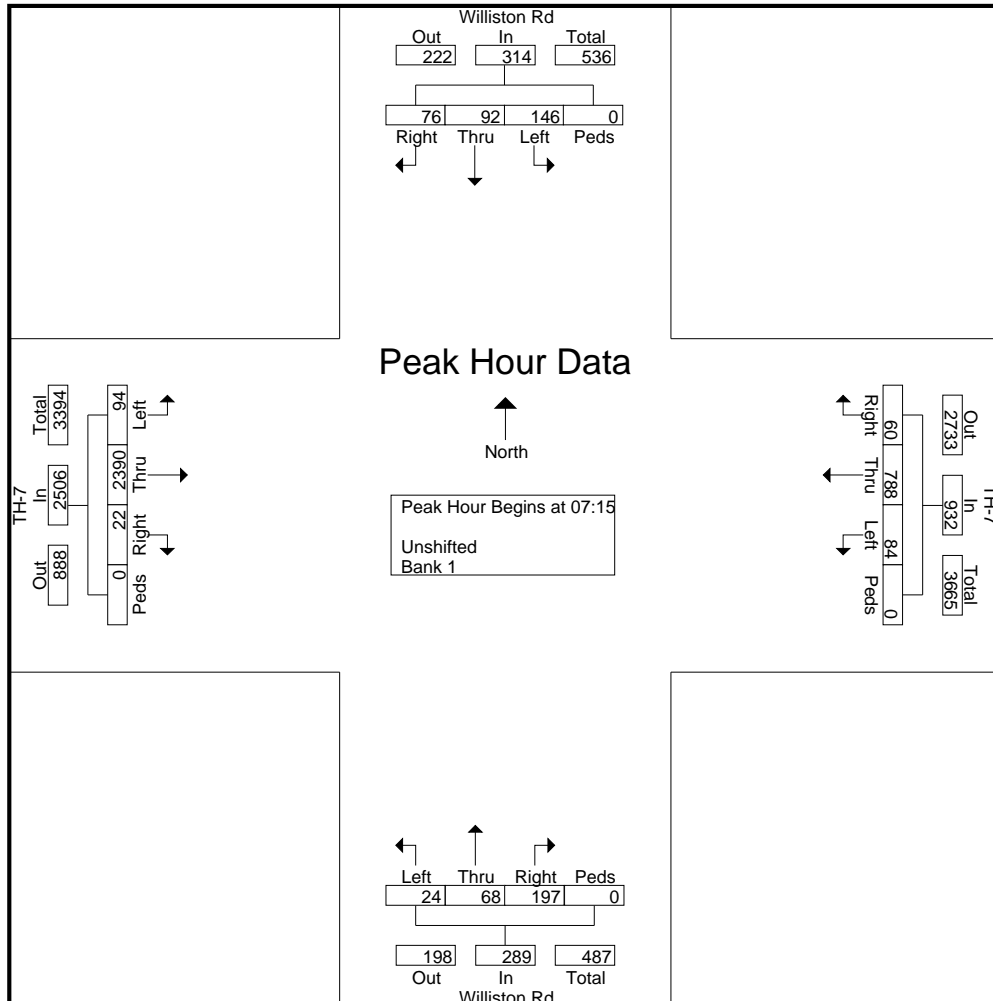

Alliant Engineering Inc Minneapolis, MN 55415

TH-7 at Williston Rd.
Ref.Pt.: 188.039
Alliant Engineering Inc
TURN MOVEMENT COUNT

File Name : 11_TH 7 at Williston Rd_011211
Site Code : 00000011
Start Date : 1/12/2011
Page No : 4

Start Time	Williston Rd Southbound					TH-7 Westbound					Williston Rd Northbound					TH-7 Eastbound					Int. Total
	Left	Thru	Right	Peds	App. Total	Left	Thru	Right	Peds	App. Total	Left	Thru	Right	Peds	App. Total	Left	Thru	Right	Peds	App. Total	
Peak Hour Analysis From 14:30 to 17:45 - Peak 1 of 1																					
Peak Hour for Entire Intersection Begins at 16:45																					
16:45	45	22	30	0	97	41	469	10	0	520	19	27	11	0	57	39	311	8	0	358	1032
17:00	51	43	31	0	125	49	494	36	0	579	17	29	14	0	60	26	234	12	0	272	1036
17:15	37	37	37	0	111	35	498	19	1	553	23	24	11	0	58	31	276	9	0	316	1038
17:30	29	28	34	0	91	60	485	20	0	565	28	34	11	0	73	29	230	5	0	264	993
Total Volume	162	130	132	0	424	185	1946	85	1	2217	87	114	47	0	248	125	1051	34	0	1210	4099
% App. Total	38.2	30.7	31.1	0		8.3	87.8	3.8	0		35.1	46	19	0		10.3	86.9	2.8	0		
PHF	.794	.756	.892	.000	.848	.771	.977	.590	.250	.957	.777	.838	.839	.000	.849	.801	.845	.708	.000	.845	.987

