



MINNESOTA DEPT OF TRANSPORTATION

TRAFFIC DATA COLLECTION - METRO

Blake Rd at Cambridge St., Hopkins
 ref.pt.:
 collected by: ALLIANT CONSULT.
 TURN MOVEMENT COUNT

File Name : Blake Rd at Cambridge St 2007
 Site Code : 00000161
 Start Date : 12/13/2007
 Page No : 1

Groups Printed- Cars & Trucks

Start Time	Blake Rd Southbound				Cambridge St Westbound				Blake Rd Northbound				Cambridge St Eastbound				Int. Total
	Left	Thru	Right	Peds	Left	Thru	Right	Peds	Left	Thru	Right	Peds	Left	Thru	Right	Peds	
06:00	0	21	1	0	0	1	4	0	2	17	2	0	11	1	2	0	62
06:15	6	26	3	0	0	1	5	0	2	26	0	0	15	2	4	0	90
06:30	0	40	4	0	5	2	4	0	2	44	0	0	15	1	8	0	125
06:45	2	47	3	0	4	1	3	0	2	44	1	0	22	2	7	0	138
Total	8	134	11	0	9	5	16	0	8	131	3	0	63	6	21	0	415
07:00	3	40	3	0	3	5	8	0	3	43	2	0	32	2	6	0	150
07:15	3	51	2	0	2	0	8	0	7	65	0	0	26	3	7	0	174
07:30	3	61	2	0	3	3	12	0	5	94	3	0	38	3	8	0	235
07:45	3	81	3	0	6	3	6	0	2	73	1	0	30	4	7	0	219
Total	12	233	10	0	14	11	34	0	17	275	6	0	126	12	28	0	778
08:00	3	68	1	0	10	4	9	0	5	60	3	0	27	0	9	0	199
08:15	2	107	3	0	4	2	1	0	14	91	5	0	44	2	12	0	287
08:30	7	72	5	0	4	5	6	0	8	106	4	0	47	2	6	0	272
08:45	2	66	4	0	2	4	4	0	3	107	5	0	56	2	13	0	268
Total	14	313	13	0	20	15	20	0	30	364	17	0	174	6	40	0	1026
09:00	5	84	7	0	6	2	3	0	13	84	2	0	32	1	7	0	246
09:15	3	73	7	0	2	0	6	0	7	90	2	0	37	4	4	0	235
*** BREAK ***																	
Total	8	157	14	0	8	2	9	0	20	174	4	0	69	5	11	0	481
*** BREAK ***																	
10:30	3	73	7	0	3	2	5	0	8	74	1	0	26	3	11	0	216
10:45	9	74	7	0	4	0	3	0	9	76	1	0	24	1	10	0	218
Total	12	147	14	0	7	2	8	0	17	150	2	0	50	4	21	0	434
11:00	5	92	15	0	4	5	3	0	15	72	1	0	34	1	11	0	258
11:15	9	88	17	0	3	2	1	0	5	63	2	0	48	3	22	0	263
11:30	1	96	16	0	2	4	4	1	14	94	2	0	52	4	20	0	310
11:45	7	89	25	0	9	4	2	0	19	107	4	0	51	6	18	0	341
Total	22	365	73	0	18	15	10	1	53	336	9	0	185	14	71	0	1172
12:00	4	100	25	0	9	6	3	0	22	109	4	0	62	14	27	0	385
12:15	8	123	38	0	4	5	8	0	26	112	4	0	61	2	31	0	422
12:30	2	112	26	0	8	5	5	0	21	126	5	0	75	7	29	0	421
12:45	7	122	17	0	9	2	6	0	16	117	3	0	62	4	26	0	391
Total	21	457	106	0	30	18	22	0	85	464	16	0	260	27	113	0	1619
13:00	8	123	14	0	5	7	6	0	12	101	1	0	56	1	21	0	355
13:15	10	114	8	0	10	7	4	0	16	100	4	0	52	5	20	0	350
*** BREAK ***																	
Total	18	237	22	0	15	14	10	0	28	201	5	0	108	6	41	0	705
*** BREAK ***																	
14:30	8	75	14	0	4	6	5	0	7	118	4	0	45	3	19	0	308
14:45	8	85	9	0	4	6	6	0	13	111	5	0	47	5	20	0	319
Total	16	160	23	0	8	12	11	0	20	229	9	0	92	8	39	0	627
15:00	10	99	15	0	3	2	2	0	16	107	5	0	43	4	20	0	326
15:15	9	110	12	0	5	6	4	0	17	111	4	0	42	4	15	0	339
15:30	9	118	14	0	4	4	6	0	12	158	8	0	31	7	17	0	388
15:45	3	96	8	0	4	10	6	0	9	170	6	0	41	3	16	0	372
Total	31	423	49	0	16	22	18	0	54	546	23	0	157	18	68	0	1425



MINNESOTA DEPT OF TRANSPORTATION

TRAFFIC DATA COLLECTION - METRO

Blake Rd at Cambridge St., Hopkins
 ref.pt.:
 collected by: ALLIANT CONSULT.
 TURN MOVEMENT COUNT

File Name : Blake Rd at Cambridge St 2007
 Site Code : 00000161
 Start Date : 12/13/2007
 Page No : 2

Groups Printed- Cars & Trucks

Start Time	Blake Rd Southbound				Cambridge St Westbound				Blake Rd Northbound				Cambridge St Eastbound				Int. Total
	Left	Thru	Right	Peds	Left	Thru	Right	Peds	Left	Thru	Right	Peds	Left	Thru	Right	Peds	
16:00	7	111	15	0	3	2	3	0	11	148	6	0	35	4	23	0	368
16:15	6	127	12	0	9	7	3	0	24	165	10	0	45	5	19	0	432
16:30	8	132	13	0	7	3	3	0	10	170	6	0	41	7	13	0	413
16:45	4	120	13	0	3	6	3	0	16	149	8	0	50	8	18	0	398
Total	25	490	53	0	22	18	12	0	61	632	30	0	171	24	73	0	1611
17:00	8	110	17	0	7	3	5	0	21	148	5	0	45	7	15	0	391
17:15	6	128	19	0	5	2	3	0	20	136	6	0	47	7	20	0	399
17:30	7	140	24	0	7	7	8	0	21	132	8	0	49	4	26	0	433
17:45	4	125	22	0	8	4	1	0	14	139	8	0	41	3	18	0	387
Total	25	503	82	0	27	16	17	0	76	555	27	0	182	21	79	0	1610
Grand Total	212	3619	470	0	194	150	187	1	469	4057	151	0	1637	151	605	0	11903
Apprch %	4.9	84.1	10.9	0	36.5	28.2	35.2	0.2	10	86.7	3.2	0	68.4	6.3	25.3	0	
Total %	1.8	30.4	3.9	0	1.6	1.3	1.6	0	3.9	34.1	1.3	0	13.8	1.3	5.1	0	



MINNESOTA DEPT OF TRANSPORTATION

TRAFFIC DATA COLLECTION - METRO

Blake Rd at Cambridge St., Hopkins
 ref.pt.:
 collected by: ALLIANT CONSULT.
 TURN MOVEMENT COUNT

File Name : Blake Rd at Cambridge St 2007
 Site Code : 00000161
 Start Date : 12/13/2007
 Page No : 3

Start Time	Blake Rd Southbound					Cambridge St Westbound					Blake Rd Northbound					Cambridge St Eastbound					Int. Total
	Left	Thru	Right	Peds	App. Total	Left	Thru	Right	Peds	App. Total	Left	Thru	Right	Peds	App. Total	Left	Thru	Right	Peds	App. Total	
Peak Hour Analysis From 06:00 to 09:15 - Peak 1 of 1																					
Peak Hour for Entire Intersection Begins at 08:15																					
08:15	2	107	3	0	112	4	2	1	0	7	14	91	5	0	110	44	2	12	0	58	287
08:30	7	72	5	0	84	4	5	6	0	15	8	106	4	0	118	47	2	6	0	55	272
08:45	2	66	4	0	72	2	4	4	0	10	3	107	5	0	115	56	2	13	0	71	268
09:00	5	84	7	0	96	6	2	3	0	11	13	84	2	0	99	32	1	7	0	40	246
Total Volume	16	329	19	0	364	16	13	14	0	43	38	388	16	0	442	179	7	38	0	224	1073
% App. Total																					
PHF	.571	.769	.679	.000	.813	.667	.650	.583	.000	.717	.679	.907	.800	.000	.936	.799	.875	.731	.000	.789	.935

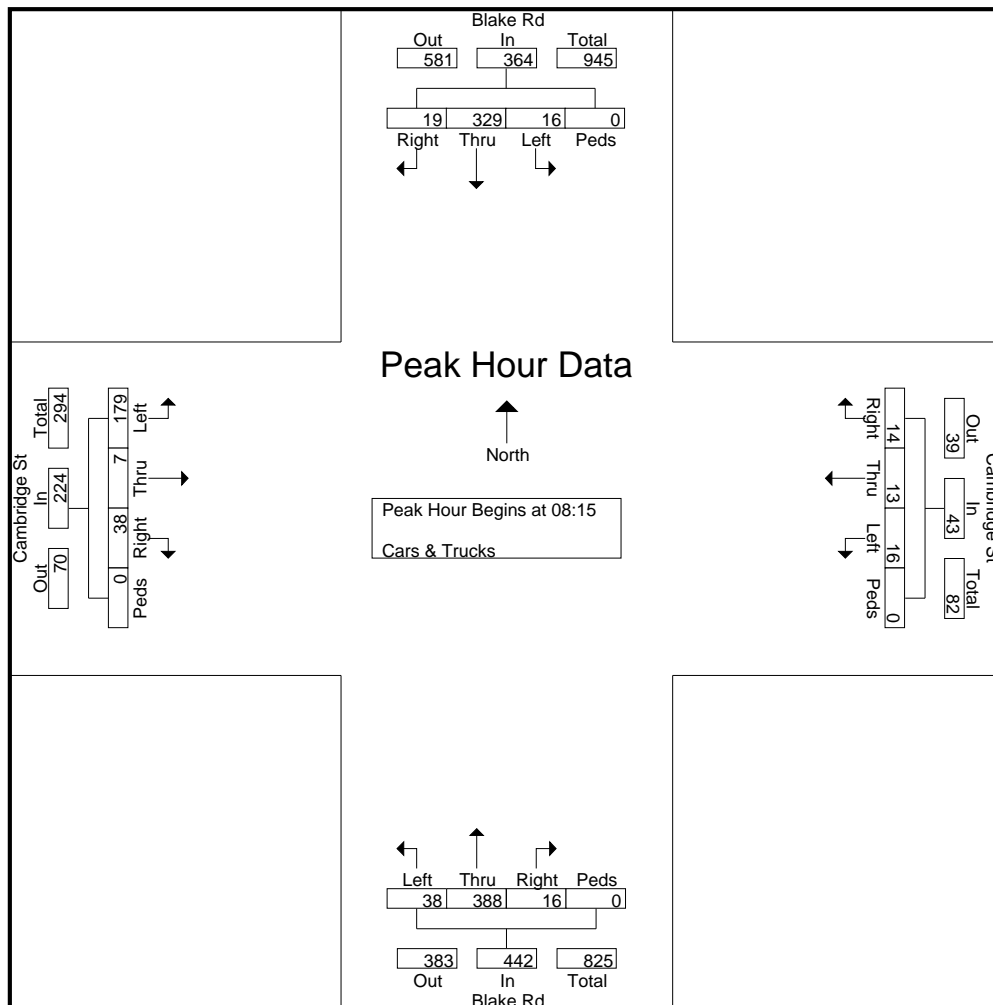



MINNESOTA DEPT OF TRANSPORTATION

TRAFFIC DATA COLLECTION - METRO

Blake Rd at Cambridge St., Hopkins
 ref.pt.:
 collected by: ALLIANT CONSULT.
 TURN MOVEMENT COUNT

File Name : Blake Rd at Cambridge St 2007
 Site Code : 00000161
 Start Date : 12/13/2007
 Page No : 4

Start Time	Blake Rd Southbound					Cambridge St Westbound					Blake Rd Northbound					Cambridge St Eastbound					Int. Total
	Left	Thru	Right	Peds	App. Total	Left	Thru	Right	Peds	App. Total	Left	Thru	Right	Peds	App. Total	Left	Thru	Right	Peds	App. Total	
Peak Hour Analysis From 14:30 to 17:45 - Peak 1 of 1																					
Peak Hour for Entire Intersection Begins at 16:15																					
16:15	6	127	12	0	145	9	7	3	0	19	24	165	10	0	199	45	5	19	0	69	432
16:30	8	132	13	0	153	7	3	3	0	13	10	170	6	0	186	41	7	13	0	61	413
16:45	4	120	13	0	137	3	6	3	0	12	16	149	8	0	173	50	8	18	0	76	398
17:00	8	110	17	0	135	7	3	5	0	15	21	148	5	0	174	45	7	15	0	67	391
Total Volume	26	489	55	0	570	26	19	14	0	59	71	632	29	0	732	181	27	65	0	273	1634
% App. Total																					
PHF	.813	.926	.809	.000	.931	.722	.679	.700	.000	.776	.740	.929	.725	.000	.920	.905	.844	.855	.000	.898	.946

