

MN Dept of Transportation

TRAFFIC DATA COLLECTION - Metro

TH-7 at Wooddale Ave S. - S ramps

Ref.Pt.: 193.705

video RE

TURN MOVEMENT COUNT

File Name : TH-7 at Wooddale Ave south ramps 2014

Site Code :

Start Date : 12/4/2014

Page No : 1

Groups Printed- Cars +

Start Time	Wooddale Ave Southbound				ramp to EB TH-7 Westbound				Wooddale Ave Northbound				ramp from EB TH-7 Eastbound				Int. Total
	Left	Thru	Right	Peds	Left	Thru	Right	Peds	Left	Thru	Right	Peds	Left	Thru	Right	Peds	
06:00	4	32	0	0	0	0	0	0	0	16	2	0	1	0	15	0	70
06:15	2	45	0	0	0	0	0	0	0	29	8	0	1	0	20	0	105
06:30	9	62	0	0	0	0	0	0	0	39	14	0	9	0	37	0	170
06:45	11	73	0	0	0	0	0	0	0	56	10	0	9	0	58	0	217
Total	26	212	0	0	0	0	0	0	0	140	34	0	20	0	130	0	562
07:00	18	84	0	0	0	0	0	0	0	104	18	0	12	1	44	0	281
07:15	13	116	0	0	0	0	0	0	0	107	31	0	24	0	50	0	341
07:30	26	111	0	0	0	0	0	0	0	139	26	0	24	0	59	0	385
07:45	20	132	0	0	0	0	0	0	0	193	35	0	21	0	69	0	470
Total	77	443	0	0	0	0	0	0	0	543	110	0	81	1	222	0	1477
08:00	23	121	0	0	0	0	0	0	0	147	30	0	11	0	57	0	389
08:15	28	115	0	0	0	0	0	0	0	163	25	0	7	0	61	0	399
08:30	17	119	0	0	0	0	0	0	0	115	25	0	14	0	49	0	339
08:45	9	93	0	0	0	0	0	0	0	97	22	0	11	0	61	0	293
Total	77	448	0	0	0	0	0	0	0	522	102	0	43	0	228	0	1420
*****BREAK*****																	
15:00	27	101	0	0	0	0	0	0	0	130	25	0	21	0	48	0	352
15:15	27	122	0	0	0	0	0	0	0	135	19	0	18	0	59	0	380
15:30	21	98	0	0	0	0	0	0	0	154	28	0	19	0	49	0	369
15:45	17	87	0	0	0	0	0	0	0	159	17	0	16	1	57	0	354
Total	92	408	0	0	0	0	0	0	0	578	89	0	74	1	213	0	1455
16:00	12	104	0	0	0	0	0	0	0	210	43	0	21	0	56	0	446
16:15	19	100	0	0	0	0	0	0	0	213	35	0	16	0	74	0	457
16:30	10	81	0	0	0	0	0	0	0	212	35	0	20	1	78	0	437
16:45	12	109	0	0	0	0	0	0	0	218	26	0	10	0	63	0	438
Total	53	394	0	0	0	0	0	0	0	853	139	0	67	1	271	0	1778
17:00	17	126	0	0	0	0	0	0	0	251	34	0	24	0	74	0	526
17:15	13	105	0	0	0	0	0	0	0	259	26	0	19	0	85	0	507
17:30	24	125	0	0	0	0	0	0	0	238	20	0	23	0	67	0	497
17:45	17	116	0	0	0	0	0	0	0	215	30	0	27	0	69	0	474
Total	71	472	0	0	0	0	0	0	0	963	110	0	93	0	295	0	2004
Grand Total	396	2377	0	0	0	0	0	0	0	3599	584	0	378	3	1359	0	8696
Apprch %	14.3	85.7	0	0	0	0	0	0	0	86	14	0	21.7	0.2	78.1	0	
Total %	4.6	27.3	0	0	0	0	0	0	0	41.4	6.7	0	4.3	0	15.6	0	

MN Dept of Transportation

TRAFFIC DATA COLLECTION - Metro

TH-7 at Wooddale Ave S. - S ramps
 Ref.Pt.: 193.705
 video RE
 TURN MOVEMENT COUNT

File Name : TH-7 at Wooddale Ave south ramps 2014
 Site Code :
 Start Date : 12/4/2014
 Page No : 2

Start Time	Wooddale Ave Southbound					ramp to EB TH-7 Westbound					Wooddale Ave Northbound					ramp from EB TH-7 Eastbound					Int. Total
	Left	Thru	Right	Peds	App. Total	Left	Thru	Right	Peds	App. Total	Left	Thru	Right	Peds	App. Total	Left	Thru	Right	Peds	App. Total	
Peak Hour Analysis From 06:00 to 08:45 - Peak 1 of 1																					
Peak Hour for Entire Intersection Begins at 07:30																					
07:30	26	111	0	0	137	0	0	0	0	0	0	139	26	0	165	24	0	59	0	83	385
07:45	20	132	0	0	152	0	0	0	0	0	0	193	35	0	228	21	0	69	0	90	470
08:00	23	121	0	0	144	0	0	0	0	0	0	147	30	0	177	11	0	57	0	68	389
08:15	28	115	0	0	143	0	0	0	0	0	0	163	25	0	188	7	0	61	0	68	399
Total Volume	97	479	0	0	576	0	0	0	0	0	0	642	116	0	758	63	0	246	0	309	1643
% App. Total	16.8	83.2	0	0		0	0	0	0	0	0	84.7	15.3	0		20.4	0	79.6	0		
PHF	.866	.907	.000	.000	.947	.000	.000	.000	.000	.000	.000	.832	.829	.000	.831	.656	.000	.891	.000	.858	.874

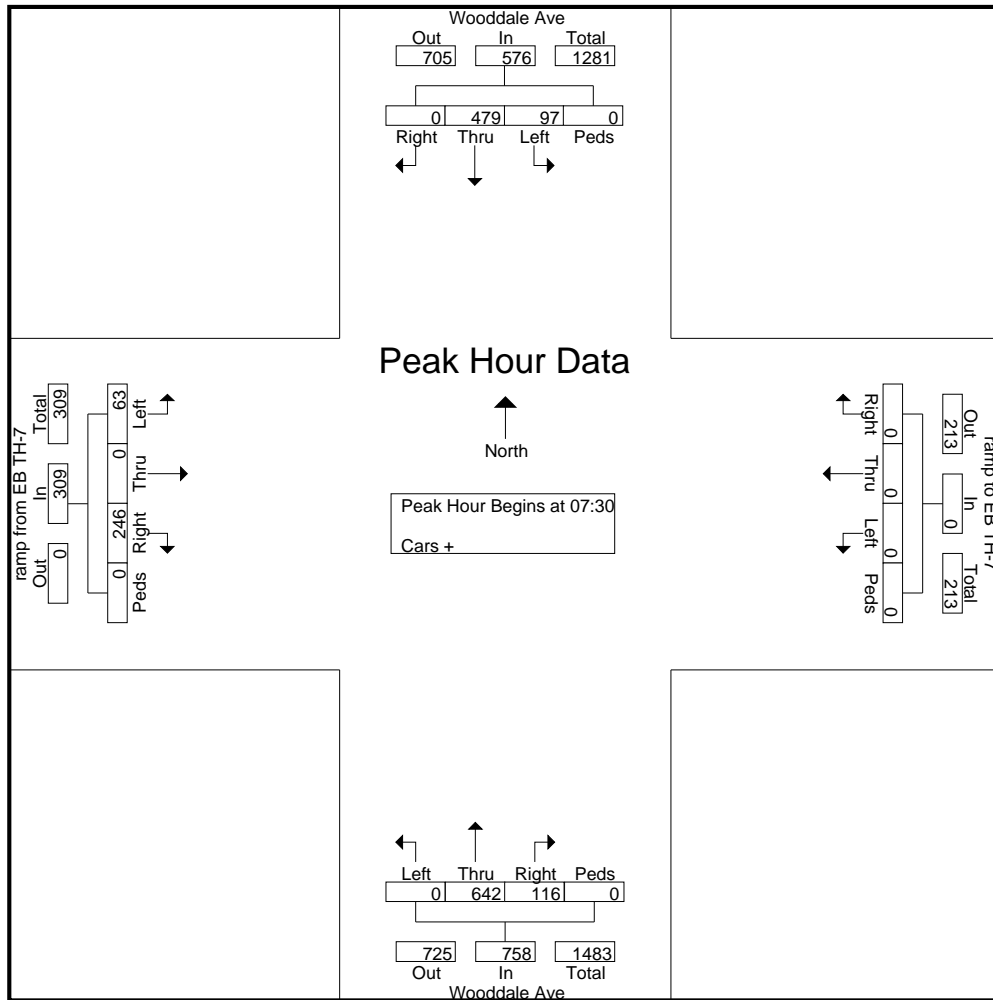

MN Dept of Transportation

TRAFFIC DATA COLLECTION - Metro

TH-7 at Wooddale Ave S. - S ramps
 Ref.Pt.: 193.705
 video RE
 TURN MOVEMENT COUNT

File Name : TH-7 at Wooddale Ave south ramps 2014
 Site Code :
 Start Date : 12/4/2014
 Page No : 3

Start Time	Wooddale Ave Southbound					ramp to EB TH-7 Westbound					Wooddale Ave Northbound					ramp from EB TH-7 Eastbound					Int. Total
	Left	Thru	Right	Peds	App. Total	Left	Thru	Right	Peds	App. Total	Left	Thru	Right	Peds	App. Total	Left	Thru	Right	Peds	App. Total	
Peak Hour Analysis From 15:00 to 17:45 - Peak 1 of 1																					
Peak Hour for Entire Intersection Begins at 17:00																					
17:00	17	126	0	0	143	0	0	0	0	0	0	251	34	0	285	24	0	74	0	98	526
17:15	13	105	0	0	118	0	0	0	0	0	0	259	26	0	285	19	0	85	0	104	507
17:30	24	125	0	0	149	0	0	0	0	0	0	238	20	0	258	23	0	67	0	90	497
17:45	17	116	0	0	133	0	0	0	0	0	0	215	30	0	245	27	0	69	0	96	474
Total Volume	71	472	0	0	543	0	0	0	0	0	0	963	110	0	1073	93	0	295	0	388	2004
% App. Total	13.1	86.9	0	0		0	0	0	0		0	89.7	10.3	0		24	0	76	0		
PHF	.740	.937	.000	.000	.911	.000	.000	.000	.000	.000	.000	.930	.809	.000	.941	.861	.000	.868	.000	.933	.952

