



# MINNESOTA DEPT OF TRANSPORTATION

## TRAFFIC DATA COLLECTION - METRO

TH-7 at TH-100, West Ramps  
 ref.pt.: 194.109  
 collected by: ALLIANT CONSULT.  
 TURN MOVEMENT COUNT

File Name : TH-7 at TH-100 West ramps 2007  
 Site Code : 00000167  
 Start Date : 12/12/2007  
 Page No : 1

Groups Printed- Cars & Trucks

Start Time	ramp from SB TH-100 Southbound				TH-7 Westbound				ramp to SB TH-100 Northbound				TH-7 Eastbound				Int. Total
	Left	Thru	Right	Peds	Left	Thru	Right	Peds	Left	Thru	Right	Peds	Left	Thru	Right	Peds	
06:00	23	0	76	0	0	29	0	0	0	0	0	0	6	66	0	0	200
06:15	45	0	99	0	0	43	17	0	0	0	0	0	3	91	0	0	298
06:30	58	0	133	0	0	52	35	0	0	0	0	0	21	135	0	0	434
06:45	64	0	136	0	0	76	21	0	0	0	0	0	21	112	0	0	430
Total	190	0	444	0	0	200	73	0	0	0	0	0	51	404	0	0	1362
07:00	51	0	115	0	0	70	45	0	0	0	0	0	14	178	0	0	473
07:15	57	0	99	4	0	88	54	0	0	0	0	0	20	270	0	0	592
07:30	47	0	99	0	0	152	71	0	0	0	0	0	37	343	0	0	749
07:45	78	0	103	0	0	130	67	0	0	0	0	0	28	372	0	0	778
Total	233	0	416	4	0	440	237	0	0	0	0	0	99	1163	0	0	2592
08:00	63	0	87	0	0	111	62	0	0	0	0	0	31	298	0	0	652
08:15	59	0	96	0	0	123	55	0	0	0	0	0	28	323	0	0	684
08:30	58	0	108	0	0	139	52	0	0	0	0	0	36	264	0	0	657
08:45	68	0	77	1	0	124	47	0	0	0	0	0	30	249	0	0	596
Total	248	0	368	1	0	497	216	0	0	0	0	0	125	1134	0	0	2589
09:00	41	0	87	0	0	98	54	0	0	0	0	0	27	209	0	0	516
09:15	46	0	81	0	0	97	36	0	0	0	0	0	18	177	0	0	455
*** BREAK ***																	
Total	87	0	168	0	0	195	90	0	0	0	0	0	45	386	0	0	971
*** BREAK ***																	
10:30	43	0	65	0	0	89	40	0	0	0	0	0	35	116	0	0	388
10:45	39	0	90	0	0	99	49	0	0	0	0	0	40	146	0	0	463
Total	82	0	155	0	0	188	89	0	0	0	0	0	75	262	0	0	851
11:00	57	1	87	0	0	104	36	0	0	0	0	0	36	149	0	0	470
11:15	47	0	75	0	0	119	29	0	0	0	0	0	25	148	0	0	443
11:30	46	0	119	0	0	145	42	0	0	0	0	0	48	152	0	0	552
11:45	73	0	95	0	0	117	35	0	0	0	0	0	27	164	0	0	511
Total	223	1	376	0	0	485	142	0	0	0	0	0	136	613	0	0	1976
12:00	62	0	88	0	0	104	38	0	0	0	0	0	27	167	0	0	486
12:15	54	0	76	0	0	144	24	2	0	0	0	0	25	180	0	0	505
12:30	41	0	79	0	0	106	36	0	0	0	0	0	44	173	0	0	479
12:45	47	0	92	0	0	124	40	0	0	0	0	0	37	202	0	0	542
Total	204	0	335	0	0	478	138	2	0	0	0	0	133	722	0	0	2012
13:00	50	0	63	0	0	137	51	0	0	0	0	0	29	162	0	0	492
13:15	54	0	87	0	0	144	31	0	0	0	0	0	36	114	0	0	466
*** BREAK ***																	
Total	104	0	150	0	0	281	82	0	0	0	0	0	65	276	0	0	958
*** BREAK ***																	
14:30	46	0	125	0	0	163	43	0	0	0	0	0	35	216	0	0	628
14:45	59	0	101	0	0	141	37	0	0	0	0	0	48	169	0	0	555
Total	105	0	226	0	0	304	80	0	0	0	0	0	83	385	0	0	1183
15:00	40	0	98	0	0	133	39	0	0	0	0	0	38	257	0	0	605
15:15	51	0	113	0	0	165	38	0	0	0	0	0	25	248	0	0	640
15:30	43	0	89	0	0	138	35	0	0	0	0	0	33	262	0	0	600
15:45	74	0	108	0	0	185	29	0	0	0	0	0	33	287	0	0	716
Total	208	0	408	0	0	621	141	0	0	0	0	0	129	1054	0	0	2561



# MINNESOTA DEPT OF TRANSPORTATION

## TRAFFIC DATA COLLECTION - METRO

TH-7 at TH-100, West Ramps  
 ref.pt.: 194.109  
 collected by: ALLIANT CONSULT.  
 TURN MOVEMENT COUNT

File Name : TH-7 at TH-100 West ramps 2007  
 Site Code : 00000167  
 Start Date : 12/12/2007  
 Page No : 2

Groups Printed- Cars & Trucks

Start Time	ramp from SB TH-100 Southbound				TH-7 Westbound				ramp to SB TH-100 Northbound				TH-7 Eastbound				Int. Total
	Left	Thru	Right	Peds	Left	Thru	Right	Peds	Left	Thru	Right	Peds	Left	Thru	Right	Peds	
16:00	51	0	96	0	0	206	43	0	0	0	0	0	41	341	0	0	778
16:15	47	0	94	0	0	171	36	0	0	0	0	0	33	345	0	0	726
16:30	49	0	98	0	0	193	48	0	0	0	0	0	34	330	0	0	752
16:45	46	0	101	0	0	219	39	0	0	0	0	0	34	318	0	0	757
Total	193	0	389	0	0	789	166	0	0	0	0	0	142	1334	0	0	3013
17:00	47	0	93	0	0	231	39	0	0	0	0	0	38	342	0	0	790
17:15	60	0	86	0	0	236	38	0	0	0	0	0	33	347	0	0	800
17:30	51	0	102	0	0	164	58	0	0	0	0	0	40	322	0	0	737
17:45	66	0	139	0	0	179	45	0	0	0	0	0	32	309	0	0	770
Total	224	0	420	0	0	810	180	0	0	0	0	0	143	1320	0	0	3097
Grand Total	2101	1	3855	5	0	5288	1634	2	0	0	0	0	1226	9053	0	0	23165
Apprch %	35.2	0	64.7	0.1	0	76.4	23.6	0	0	0	0	0	11.9	88.1	0	0	
Total %	9.1	0	16.6	0	0	22.8	7.1	0	0	0	0	0	5.3	39.1	0	0	



# MINNESOTA DEPT OF TRANSPORTATION

## TRAFFIC DATA COLLECTION - METRO

TH-7 at TH-100, West Ramps  
 ref.pt.: 194.109  
 collected by: ALLIANT CONSULT.  
 TURN MOVEMENT COUNT

File Name : TH-7 at TH-100 West ramps 2007  
 Site Code : 00000167  
 Start Date : 12/12/2007  
 Page No : 3

Start Time	ramp from SB TH-100 Southbound					TH-7 Westbound					ramp to SB TH-100 Northbound					TH-7 Eastbound					Int. Total
	Left	Thru	Right	Peds	App. Total	Left	Thru	Right	Peds	App. Total	Left	Thru	Right	Peds	App. Total	Left	Thru	Right	Peds	App. Total	
Peak Hour Analysis From 06:00 to 09:15 - Peak 1 of 1																					
Peak Hour for Entire Intersection Begins at 07:30																					
07:30	47	0	99	0	146	0	152	71	0	223	0	0	0	0	0	37	343	0	0	380	749
07:45	78	0	103	0	181	0	130	67	0	197	0	0	0	0	0	28	372	0	0	400	778
08:00	63	0	87	0	150	0	111	62	0	173	0	0	0	0	0	31	298	0	0	329	652
08:15	59	0	96	0	155	0	123	55	0	178	0	0	0	0	0	28	323	0	0	351	684
Total Volume	247	0	385	0	632	0	516	255	0	771	0	0	0	0	0	124	1336	0	0	1460	2863
% App. Total	39.1	0	60.9	0		0	66.9	33.1	0		0	0	0	0		8.5	91.5	0	0		
PHF	.792	.000	.934	.000	.873	.000	.849	.898	.000	.864	.000	.000	.000	.000	.000	.838	.898	.000	.000	.913	.920

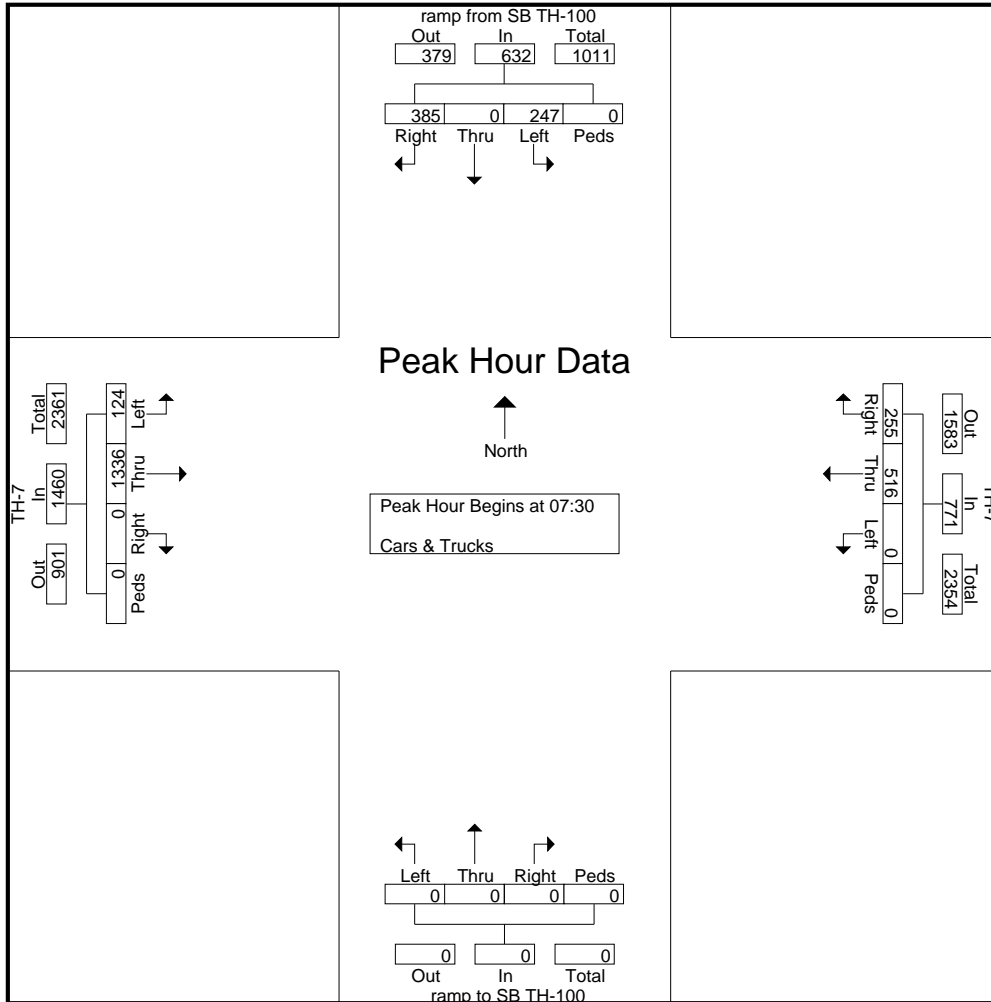



# MINNESOTA DEPT OF TRANSPORTATION

## TRAFFIC DATA COLLECTION - METRO

TH-7 at TH-100, West Ramps  
 ref.pt.: 194.109  
 collected by: ALLIANT CONSULT.  
 TURN MOVEMENT COUNT

File Name : TH-7 at TH-100 West ramps 2007  
 Site Code : 00000167  
 Start Date : 12/12/2007  
 Page No : 4

Start Time	ramp from SB TH-100 Southbound					TH-7 Westbound					ramp to SB TH-100 Northbound					TH-7 Eastbound					Int. Total
	Left	Thru	Right	Peds	App. Total	Left	Thru	Right	Peds	App. Total	Left	Thru	Right	Peds	App. Total	Left	Thru	Right	Peds	App. Total	
Peak Hour Analysis From 15:00 to 17:45 - Peak 1 of 1																					
Peak Hour for Entire Intersection Begins at 16:30																					
16:30	49	0	98	0	147	0	193	48	0	241	0	0	0	0	0	34	330	0	0	364	752
16:45	46	0	101	0	147	0	219	39	0	258	0	0	0	0	0	34	318	0	0	352	757
17:00	47	0	93	0	140	0	231	39	0	270	0	0	0	0	0	38	342	0	0	380	790
17:15	60	0	86	0	146	0	236	38	0	274	0	0	0	0	0	33	347	0	0	380	800
Total Volume	202	0	378	0	580	0	879	164	0	1043	0	0	0	0	0	139	1337	0	0	1476	3099
% App. Total	34.8	0	65.2	0		0	84.3	15.7	0		0	0	0	0		9.4	90.6	0	0		
PHF	.842	.000	.936	.000	.986	.000	.931	.854	.000	.952	.000	.000	.000	.000	.000	.914	.963	.000	.000	.971	.968

