

MN Dept of Transportation

TRAFFIC DATA COLLECTION - Metro

TH-77 at 66th St, EAST RAMPS
 Ref.Pt.: 010.559
 video RE
 TURN MOVEMENT COUNT

File Name : TH-77 at 66th Street EAST RAMPS 2015
 Site Code :
 Start Date : 7/15/2015
 Page No : 1

Groups Printed- Cars +

Start Time	ramp to TH-77 NB Southbound				66th St Westbound				ramp from TH-77 NB Northbound				66th St Eastbound				Int. Total
	Left	Thru	Right	Peds	Left	Thru	Right	Peds	Left	Thru	Right	Peds	Left	Thru	Right	Peds	
06:00	0	0	0	0	0	0	11	0	20	0	6	1	19	20	0	0	77
06:15	0	0	0	0	0	3	14	0	36	0	10	0	30	14	0	0	107
06:30	0	0	0	0	0	14	45	0	49	1	12	0	28	21	0	0	170
06:45	0	0	0	0	0	10	13	0	86	0	17	0	25	34	0	0	185
Total	0	0	0	0	0	27	83	0	191	1	45	1	102	89	0	0	539
07:00	0	0	0	0	0	29	24	0	100	3	3	0	35	23	0	0	217
07:15	0	0	0	0	0	28	18	0	201	15	4	0	47	21	0	0	334
07:30	0	0	0	1	0	33	11	0	155	1	6	3	46	31	0	0	287
07:45	0	0	0	0	0	17	5	0	186	1	7	0	58	37	0	0	311
Total	0	0	0	1	0	107	58	0	642	20	20	3	186	112	0	0	1149
08:00	0	0	0	0	0	30	27	0	99	0	9	0	58	41	0	0	264
08:15	0	0	0	0	0	17	14	0	114	1	5	0	46	56	0	0	253
08:30	0	0	0	1	0	9	24	0	123	1	3	1	59	35	0	0	256
08:45	0	0	0	0	0	21	15	0	121	1	7	1	47	38	0	0	251
Total	0	0	0	1	0	77	80	0	457	3	24	2	210	170	0	0	1024
*****BREAK*****																	
15:00	0	0	0	0	0	21	32	0	74	0	0	0	115	28	0	0	270
15:15	0	0	0	0	0	19	31	0	67	0	2	1	111	18	0	0	249
15:30	0	0	0	0	0	47	42	0	88	1	7	0	123	23	0	0	331
15:45	0	0	0	1	0	17	35	0	84	1	2	0	130	18	0	0	288
Total	0	0	0	1	0	104	140	0	313	2	11	1	479	87	0	0	1138
16:00	0	0	0	1	0	19	45	0	95	0	7	0	123	16	0	0	306
16:15	0	0	0	0	0	27	40	0	105	0	3	0	129	26	0	0	330
16:30	0	0	0	1	0	45	45	0	133	2	8	1	147	25	0	0	407
16:45	0	0	0	0	0	40	55	0	136	1	3	0	138	29	0	0	402
Total	0	0	0	2	0	131	185	0	469	3	21	1	537	96	0	0	1445
17:00	0	0	0	0	0	56	39	0	163	0	2	0	180	16	0	0	456
17:15	0	0	0	2	0	64	38	0	153	2	0	0	160	24	0	0	443
17:30	0	0	0	0	0	29	37	0	135	1	4	0	158	24	0	0	388
17:45	0	0	0	3	0	20	28	0	110	0	7	0	140	19	0	0	327
Total	0	0	0	5	0	169	142	0	561	3	13	0	638	83	0	0	1614
Grand Total	0	0	0	10	0	615	688	0	2633	32	134	8	2152	637	0	0	6909
Apprch %	0	0	0	100	0	47.2	52.8	0	93.8	1.1	4.8	0.3	77.2	22.8	0	0	
Total %	0	0	0	0.1	0	8.9	10	0	38.1	0.5	1.9	0.1	31.1	9.2	0	0	

MN Dept of Transportation

TRAFFIC DATA COLLECTION - Metro

TH-77 at 66th St, EAST RAMPS
 Ref.Pt.: 010.559
 video RE
 TURN MOVEMENT COUNT

File Name : TH-77 at 66th Street EAST RAMPS 2015
 Site Code :
 Start Date : 7/15/2015
 Page No : 2

Start Time	ramp to TH-77 NB Southbound					66th St Westbound					ramp from TH-77 NB Northbound					66th St Eastbound					Int. Total
	Left	Thru	Right	Peds	App. Total	Left	Thru	Right	Peds	App. Total	Left	Thru	Right	Peds	App. Total	Left	Thru	Right	Peds	App. Total	
Peak Hour Analysis From 06:00 to 07:45 - Peak 1 of 1																					
Peak Hour for Entire Intersection Begins at 07:00																					
07:00	0	0	0	0	0	0	29	24	0	53	100	3	3	0	106	35	23	0	0	58	217
07:15	0	0	0	0	0	0	28	18	0	46	201	15	4	0	220	47	21	0	0	68	334
07:30	0	0	0	1	1	0	33	11	0	44	155	1	6	3	165	46	31	0	0	77	287
07:45	0	0	0	0	0	0	17	5	0	22	186	1	7	0	194	58	37	0	0	95	311
Total Volume	0	0	0	1	1	0	107	58	0	165	642	20	20	3	685	186	112	0	0	298	1149
% App. Total	0	0	0	100		0	64.8	35.2	0		93.7	2.9	2.9	0.4		62.4	37.6	0	0		
PHF	.000	.000	.000	.250	.250	.000	.811	.604	.000	.778	.799	.333	.714	.250	.778	.802	.757	.000	.000	.784	.860

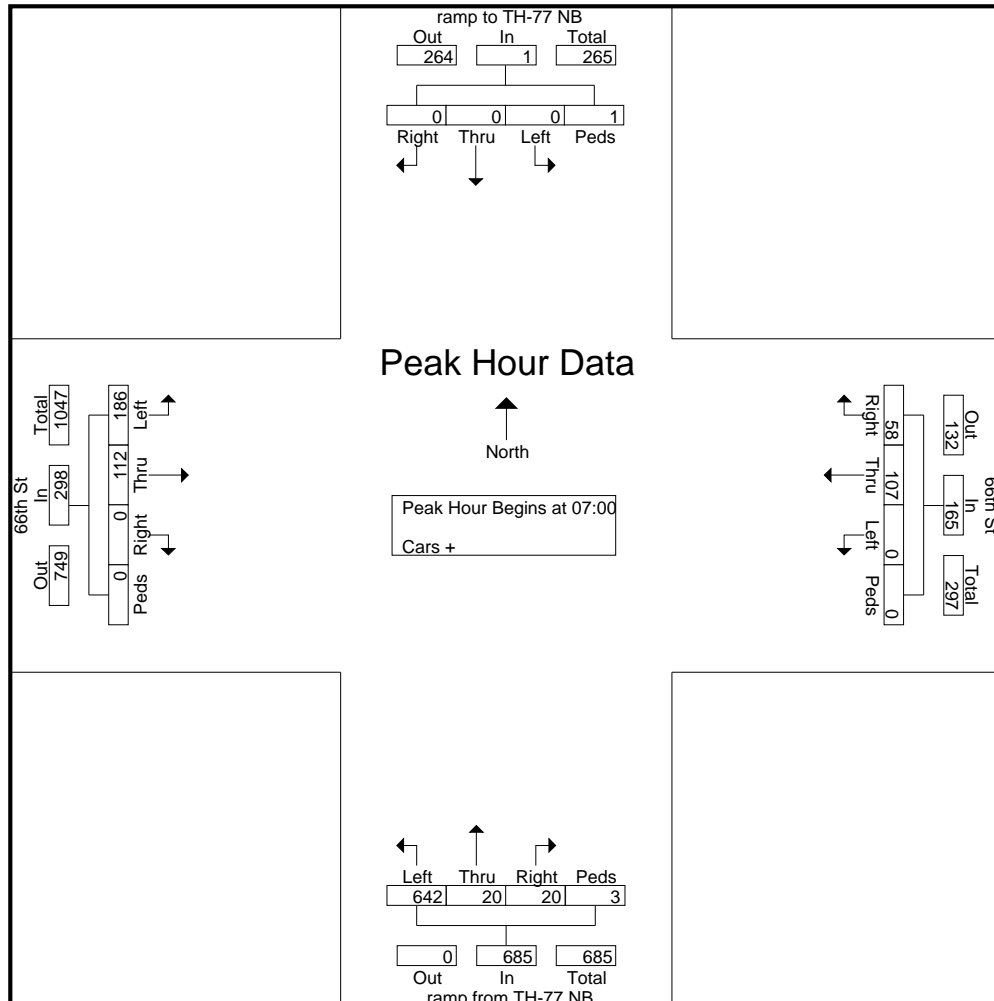

MN Dept of Transportation

TRAFFIC DATA COLLECTION - Metro

TH-77 at 66th St, EAST RAMPS
 Ref.Pt.: 010.559
 video RE
 TURN MOVEMENT COUNT

File Name : TH-77 at 66th Street EAST RAMPS 2015
 Site Code :
 Start Date : 7/15/2015
 Page No : 3

Start Time	ramp to TH-77 NB Southbound					66th St Westbound					ramp from TH-77 NB Northbound					66th St Eastbound					Int. Total
	Left	Thru	Right	Peds	App. Total	Left	Thru	Right	Peds	App. Total	Left	Thru	Right	Peds	App. Total	Left	Thru	Right	Peds	App. Total	
Peak Hour Analysis From 15:00 to 17:45 - Peak 1 of 1																					
Peak Hour for Entire Intersection Begins at 16:30																					
16:30	0	0	0	1	1	0	45	45	0	90	133	2	8	1	144	147	25	0	0	172	407
16:45	0	0	0	0	0	0	40	55	0	95	136	1	3	0	140	138	29	0	0	167	402
17:00	0	0	0	0	0	0	56	39	0	95	163	0	2	0	165	180	16	0	0	196	456
17:15	0	0	0	2	2	0	64	38	0	102	153	2	0	0	155	160	24	0	0	184	443
Total Volume	0	0	0	3	3	0	205	177	0	382	585	5	13	1	604	625	94	0	0	719	1708
% App. Total	0	0	0	100		0	53.7	46.3	0		96.9	0.8	2.2	0.2		86.9	13.1	0	0		
PHF	.000	.000	.000	.375	.375	.000	.801	.805	.000	.936	.897	.625	.406	.250	.915	.868	.810	.000	.000	.917	.936

