



MINNESOTA DEPT OF TRANSPORTATION

TRAFFIC DATA COLLECTION - METRO

TH-61 SB at 210th St., FOREST LAKE
 Ref.Pt.: 019.561
 JAMAR # 631 BR
 TURN MOVEMENT COUNT

File Name : TH-61 SB at 210th Ave N 2011
 Site Code : 00000000
 Start Date : 6/2/2011
 Page No : 1

Groups Printed- Cars & Trucks

Start Time	TH-61 SB Southbound				210th St. Westbound				TH-61 SB Northbound				210th St. Eastbound				Int. Total
	Left	Thru	Right	Peds	Left	Thru	Right	Peds	Left	Thru	Right	Peds	Left	Thru	Right	Peds	
06:00	3	48	0	0	3	43	0	0	0	0	0	0	0	6	13	0	116
06:15	3	57	0	0	2	42	0	0	0	0	0	0	0	6	11	0	121
06:30	3	64	0	0	1	43	0	0	0	0	0	0	0	6	8	0	125
06:45	4	44	0	0	3	35	0	0	0	0	0	0	0	7	13	0	106
Total	13	213	0	0	9	163	0	0	0	0	0	0	0	25	45	0	468
07:00	5	52	0	0	3	40	0	0	0	0	0	0	0	30	14	0	144
07:15	40	62	0	0	3	50	0	0	0	0	0	0	0	55	10	0	220
07:30	51	86	0	0	6	54	0	0	0	0	0	0	0	53	12	0	262
07:45	40	80	0	0	4	37	0	0	0	0	0	0	0	60	26	0	247
Total	136	280	0	0	16	181	0	0	0	0	0	0	0	198	62	0	873
08:00	15	71	0	0	0	28	0	0	0	0	0	0	0	11	11	0	136
08:15	9	40	0	0	1	22	0	0	0	0	0	0	0	6	10	0	88
08:30	9	53	0	0	5	24	0	0	0	0	0	0	0	7	13	0	111
08:45	9	62	0	0	1	24	0	0	0	0	0	0	0	7	13	0	116
Total	42	226	0	0	7	98	0	0	0	0	0	0	0	31	47	0	451
*** BREAK ***																	
14:00	22	90	0	0	2	22	0	0	0	0	0	0	0	19	15	0	170
14:15	31	60	0	0	6	23	0	0	0	0	0	0	0	17	23	0	160
14:30	12	82	0	0	9	51	0	0	0	0	0	0	0	15	17	0	186
14:45	17	91	0	0	4	59	0	0	0	0	0	0	0	12	18	0	201
Total	82	323	0	0	21	155	0	0	0	0	0	0	0	63	73	0	717
15:00	13	76	0	0	1	33	0	0	0	0	0	0	0	15	11	0	149
15:15	11	89	0	0	3	31	0	0	0	0	0	0	0	18	19	0	171
15:30	19	93	0	0	4	48	0	0	0	0	0	0	0	11	18	0	193
15:45	21	62	0	0	3	25	0	0	0	0	0	0	0	26	14	0	151
Total	64	320	0	0	11	137	0	0	0	0	0	0	0	70	62	0	664
16:00	21	109	0	0	4	27	0	0	0	0	0	0	0	19	17	0	197
16:15	13	80	0	0	2	28	0	0	0	0	0	0	0	22	16	0	161
16:30	14	93	0	0	2	42	0	0	0	0	0	0	0	17	22	0	190
16:45	24	105	0	0	2	26	0	0	0	0	0	0	0	29	17	0	203
Total	72	387	0	0	10	123	0	0	0	0	0	0	0	87	72	0	751
17:00	17	93	0	0	3	39	0	0	0	0	0	0	0	45	24	0	221
17:15	34	94	0	0	3	34	0	0	0	0	0	0	0	32	23	0	220
Grand Total	460	1936	0	0	80	930	0	0	0	0	0	0	0	551	408	0	4365
Apprch %	19.2	80.8	0	0	7.9	92.1	0	0	0	0	0	0	0	57.5	42.5	0	
Total %	10.5	44.4	0	0	1.8	21.3	0	0	0	0	0	0	0	12.6	9.3	0	



MINNESOTA DEPT OF TRANSPORTATION

TRAFFIC DATA COLLECTION - METRO

TH-61 SB at 210th St., FOREST LAKE
 Ref.Pt.: 019.561
 JAMAR # 631 BR
 TURN MOVEMENT COUNT

File Name : TH-61 SB at 210th Ave N 2011
 Site Code : 00000000
 Start Date : 6/2/2011
 Page No : 2

Start Time	TH-61 SB Southbound					210th St. Westbound					TH-61 SB Northbound					210th St. Eastbound					Int. Total
	Left	Thru	Right	Peds	App. Total	Left	Thru	Right	Peds	App. Total	Left	Thru	Right	Peds	App. Total	Left	Thru	Right	Peds	App. Total	
Peak Hour Analysis From 06:00 to 08:45 - Peak 1 of 1																					
Peak Hour for Entire Intersection Begins at 07:00																					
07:00	5	52	0	0	57	3	40	0	0	43	0	0	0	0	0	0	30	14	0	44	144
07:15	40	62	0	0	102	3	50	0	0	53	0	0	0	0	0	0	55	10	0	65	220
07:30	51	86	0	0	137	6	54	0	0	60	0	0	0	0	0	0	53	12	0	65	262
07:45	40	80	0	0	120	4	37	0	0	41	0	0	0	0	0	0	60	26	0	86	247
Total Volume	136	280	0	0	416	16	181	0	0	197	0	0	0	0	0	0	198	62	0	260	873
% App. Total	32.7	67.3	0	0		8.1	91.9	0	0		0	0	0	0	0	0	76.2	23.8	0		
PHF	.667	.814	.000	.000	.759	.667	.838	.000	.000	.821	.000	.000	.000	.000	.000	.000	.825	.596	.000	.756	.833

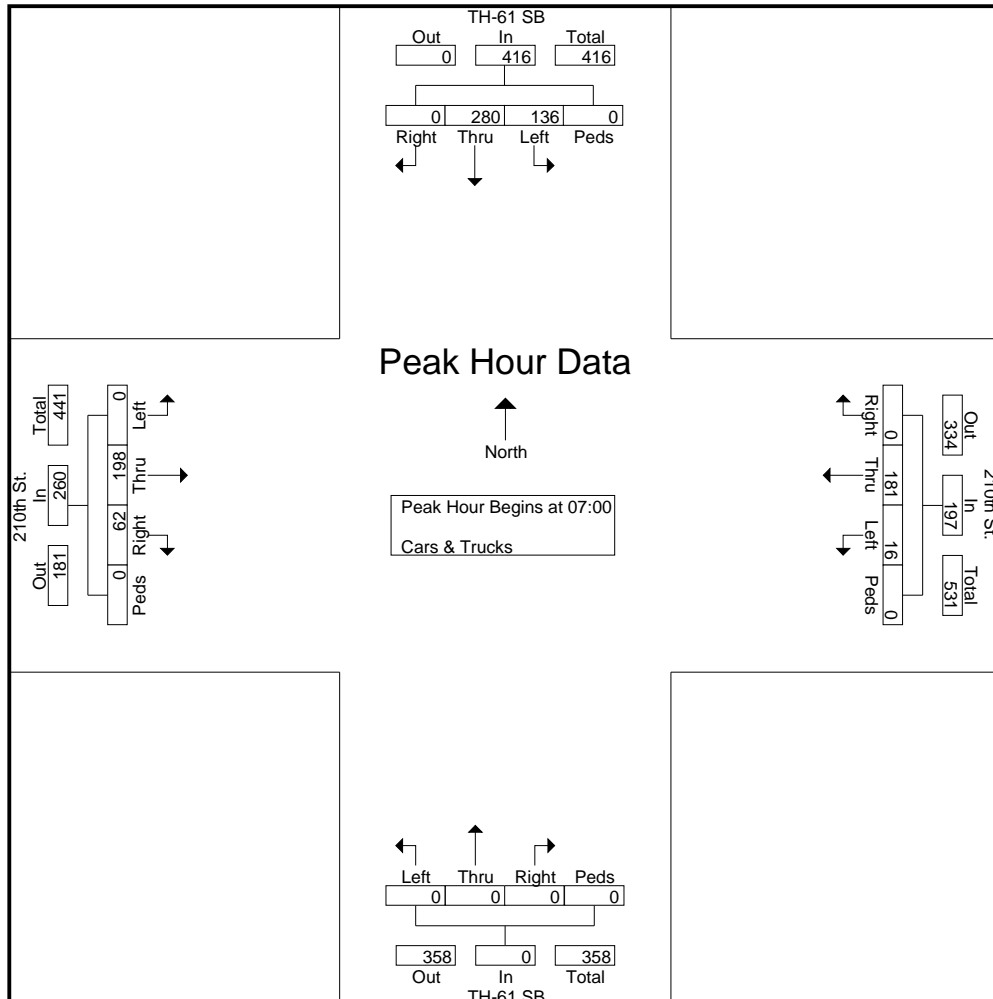



MINNESOTA DEPT OF TRANSPORTATION

TRAFFIC DATA COLLECTION - METRO

TH-61 SB at 210th St., FOREST LAKE
 Ref.Pt.: 019.561
 JAMAR # 631 BR
 TURN MOVEMENT COUNT

File Name : TH-61 SB at 210th Ave N 2011
 Site Code : 00000000
 Start Date : 6/2/2011
 Page No : 3

Start Time	TH-61 SB Southbound					210th St. Westbound					TH-61 SB Northbound					210th St. Eastbound					Int. Total
	Left	Thru	Right	Peds	App. Total	Left	Thru	Right	Peds	App. Total	Left	Thru	Right	Peds	App. Total	Left	Thru	Right	Peds	App. Total	
Peak Hour Analysis From 14:00 to 17:15 - Peak 1 of 1																					
Peak Hour for Entire Intersection Begins at 16:30																					
16:30	14	93	0	0	107	2	42	0	0	44	0	0	0	0	0	0	17	22	0	39	190
16:45	24	105	0	0	129	2	26	0	0	28	0	0	0	0	0	0	29	17	0	46	203
17:00	17	93	0	0	110	3	39	0	0	42	0	0	0	0	0	0	45	24	0	69	221
17:15	34	94	0	0	128	3	34	0	0	37	0	0	0	0	0	0	32	23	0	55	220
Total Volume	89	385	0	0	474	10	141	0	0	151	0	0	0	0	0	0	123	86	0	209	834
% App. Total	18.8	81.2	0	0		6.6	93.4	0	0		0	0	0	0	0	0	58.9	41.1	0		
PHF	.654	.917	.000	.000	.919	.833	.839	.000	.000	.858	.000	.000	.000	.000	.000	.000	.683	.896	.000	.757	.943

